

Präzisions-Werkzeugaufnahmen für innovative CNC-Fertigung

Precision toolholders
for the innovative CNC-manufacturing process

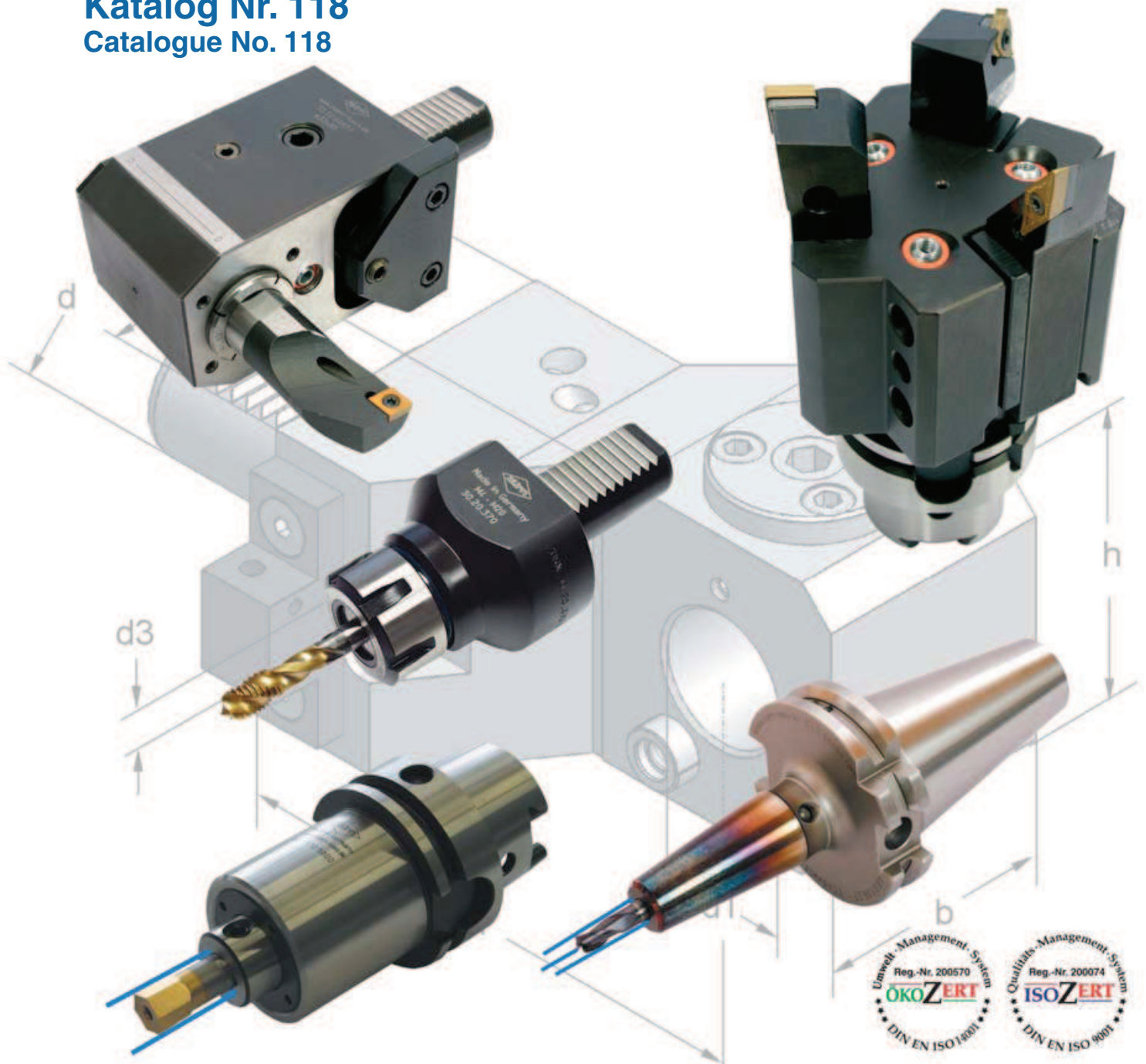

Katalog Nr. 118 Catalogue No. 118



50 Jahre Präzision Years Precision 1955-2005

- 15.01.1955** Firmengründung durch Herrn Eugen Zürn als Mech. Fertigung für Drehteile.
- 1968** Beginn der Entwicklung und Fertigung von schnellwechsel- und voreinstellbaren Werkzeughaltern für Ein- und Mehrspindel-Drehautomaten, Werkzeugaufnahmen für CNC-Drehmaschinen, Fräsmaschinen, Bearbeitungszentren und Sondermaschinen.
30 Mitarbeiter - Vertrieb weltweit.
- 1998** Zertifizierung DIN EN ISO 9001.
- 15.01.2005** 50 Jahre ist die Firma Zürn erfolgreich bemüht um Präzisions-Fertigung Made in Germany und zufriedene Kunden.

- 15th Jan. 1955** The company was founded as a factory for mechanical engineering by Eugen Zürn.
- 1968** Development and manufacturing of quick-change and pre-set toolholders for single and multiple automatics lathes, toolholders for CNC-machines, milling machines, machining centres and special machines was started.
30 employees - distribution world-wide.
- 1998** Certificate of DIN EN ISO 9001.
- 15th Jan. 2005** Company Zürn has been successfully endeavouring to manufacture Precision Toolholders Made in Germany and to satisfy the customers for 50 years.



Für Präzisions-Werkzeugaufnahmen Made in Germany spricht:

Das Gesetz der Wirtschaft verbietet es, für wenig Geld viel Wert zu erhalten.

Der Ärger über schlechte Qualität hält länger als die Freude über einen niedrigen Preis.

Es ist unklug, zu viel zu bezahlen, aber es ist noch schlechter, zu wenig zu bezahlen.

Wenn Sie zu viel bezahlen, verlieren Sie etwas Geld, das ist alles. Wenn Sie dagegen zu wenig bezahlen, verlieren Sie manchmal alles, da der gekaufte Gegenstand die ihm zugeordnete Aufgabe nicht erfüllen kann.

Argue in favour of Precision Toolholders Made in Germany

The law of economy makes impossible to get high value for little money.

Annoyance at poor quality is more long-lasting than satisfaction with the low price.

It is unwise to pay too much, but it is even worse to pay too little. If you pay too much, you may lose some money - it is all.

However, if you pay too little money, you may lose everything, because the item you have purchased is not able to fulfil the task which it had been intended for.



Produktgruppe	Seite
Product groups	Page
1 Werkzeughalter DIN 69880 für CNC-Drehmaschinen Toolholders DIN 69880 for CNC machines	5 - 33
Zangenfutter zyl. für Spannzangen ER/ESX DIN 6499-B Collet chucks cyl. for collets ER/ESX DIN 6499-B	15
Dehnspannfutter DIN 69880 Expansion chuck DIN 69880	29
2 Räumwerkzeughalter für Innenprofile Broaching toolholders for internal profiles	21 + 71
3 Steilkegelaufnahmen DIN 2080, DIN 69871, JIS B 6339 BT ISO Taper toolholders DIN 2080, DIN 69871, JIS B 6339 BT	35 - 52
4 Werkzeugaufnahmen HSK DIN 69893 Toolholders HSK DIN 69893	53 - 75
Auswucht-Service Balancing-service	36 + 71
Drehhalter HSK-A63 Turning toolholders HSK-A63	72 - 74
5 Spannzangen DIN 6388-B + DIN 6499-B Gewindebohrzangen, Type ER-GB + PCM Kraftspannmuttern Type GMG - Dichtscheiben Ersatzteile	76 - 79
Collets DIN 6388-B + DIN 6499-B Tapping collets, type ER-GB + PCM Power-locknut + sealing discs Spare parts	76 - 79
6 Voreinstellgerät + Toolfix Montagegerät Presetting equipment + Toolfix mounting equipment	80 + 81
7 Lieferbedingungen Delivery terms	82

E-Mail: info@zuern-tools.de

<http://www.zuern-tools.de>



Präzisions-Werkzeugaufnahmen ein Begriff für qualitätsbewusste Anwender

Precision toolholder for quality-conscious user



Werkstoff: Legierter Einsatzstahl mit einer Zugfestigkeit im Kern von min. 800 N/mm

Ausführung: Einsatzgehärtet HRc 60 - 2 (HV 700 ± 50)
Härtetiefe 0,8 mm - 0,2
Brüniert und Präzisionsgeschliffen

Material: Case hardened steel, tensile strength in the core min. 800 N/mm

Execution: Case hardened HRc 60 - 2 (HV 700 ± 50)
Depth of case 0,8 mm - 0,2
Brown-finish end precision ground

Technische Änderungen vorbehalten · We reserve the right to make technical changes.

Werkzeughalter für CNC-Drehmaschinen mit Zylinderschaft DIN 69880

Toolholders for CNC machines
with shank to DIN 69880

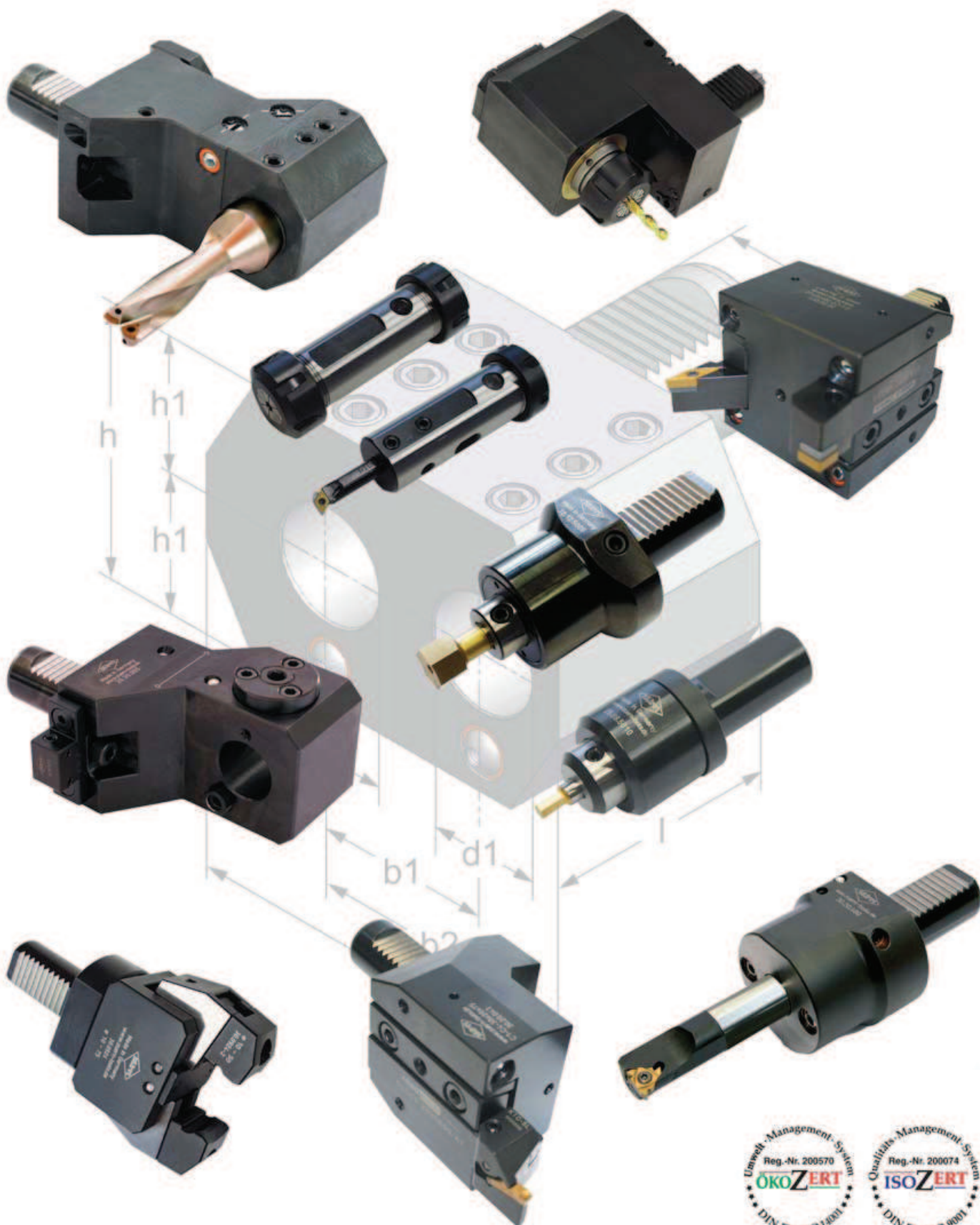

Radial-Werkzeughalter Form B1 kurz
Radial toolholder form B1 short

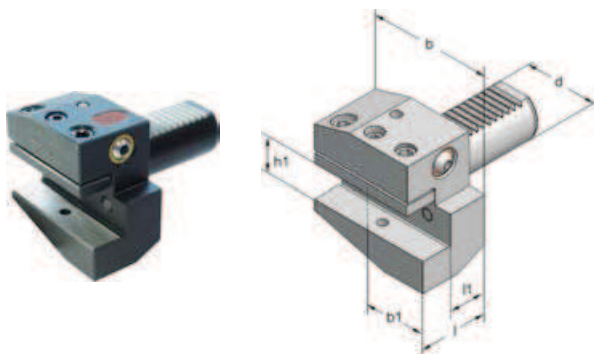

Art.-Nr.	Typ	d	b	b1	h1	l	l1
16.12.060	B1-16x12x24	16	42	23	12	24	13
20.16.060	B1-20x16x30	20	55	30	16	30	16
25.16.060	B1-25x16x30	25	55	30	16	30	16
30.20.060	B1-30x20x40	30	70	35	20	40	22
30.25.060	B1-30x25x44	30	70	35	25	44	22
40.25.060	B1-40x25x44	40	85	42,5	25	44	22
50.32.060	B1-50x32x55	50	100	50	32	55	30
60.32.060	B1-60x32x55	60	125	62,5	32	60	30
INCH							
307206	B1-30x3/4"x40	30	70	35	3/4"	40	22
343206	B1-30x1" x44	30	70	35	1"	44	22
407206	B1-40x1" x44	40	85	42,5	1"	44	22
507206	B1-50x1 1/4"x55	50	100	50	1 1/4"	55	30

Radial-Werkzeughalter Form B2 kurz
Radial toolholder form B2 short

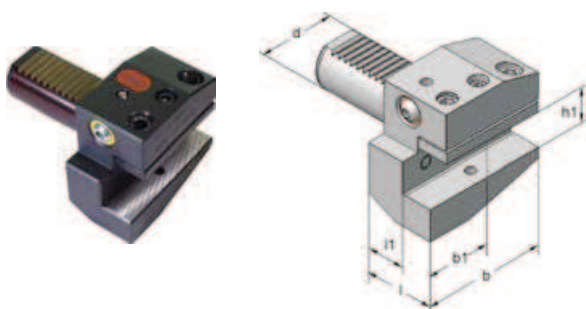

Art.-Nr.	Typ	d	b	b1	h1	l	l1
16.12.090	B2-16x12x24	16	42	23	12	24	13
20.16.090	B2-20x16x30	20	55	30	16	30	16
25.16.090	B2-25x16x30	25	55	30	16	30	16
30.20.090	B2-30x20x40	30	70	35	20	40	22
30.25.090	B2-30x25x44	30	70	35	25	44	22
40.25.090	B2-40x25x44	40	85	42,5	25	44	22
50.32.090	B2-50x32x55	50	100	50	32	55	30
60.32.090	B2-60x32x55	60	125	62,5	32	60	30
INCH							
308206	B2-30x3/4"x40	30	70	35	3/4"	40	22
344206	B2-30x1" x44	30	70	35	1"	44	22
408206	B2-40x1" x44	40	85	42,5	1"	44	22
508206	B2-50x1 1/4"x55	50	100	50	1 1/4"	55	30

Radial-Werkzeughalter Form B3 kurz
Radial toolholder form B3 short

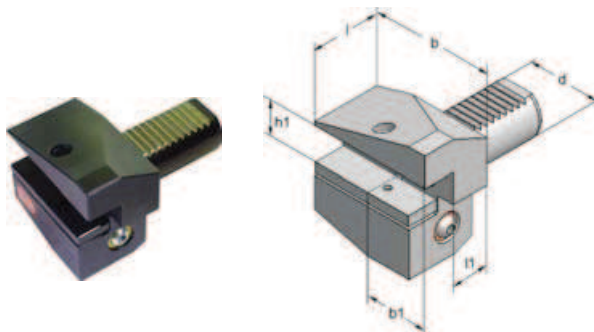

Art.-Nr.	Typ	d	b	b1	h1	l	l1
16.12.070	B3-16x12x24	16	42	23	12	24	13
20.16.070	B3-20x16x30	20	55	30	16	30	16
25.16.070	B3-25x16x30	25	55	30	16	30	16
30.20.070	B3-30x20x40	30	70	35	20	40	22
30.25.070	B3-30x25x44	30	70	35	25	44	22
40.25.070	B3-40x25x44	40	85	42,5	25	44	22
50.32.070	B3-50x32x55	50	100	50	32	55	30
60.32.070	B3-60x32x55	60	125	62,5	32	60	30
INCH							
309206	B3-30x3/4"x40	30	70	35	3/4"	40	22
345206	B3-30x1" x44	30	70	35	1"	44	22
409206	B3-40x1" x44	40	85	42,5	1"	44	22
509206	B3-50x1 1/4"x55	50	100	50	1 1/4"	55	30

Radial-Werkzeughalter Form B4 kurz
Radial toolholder form B4 short

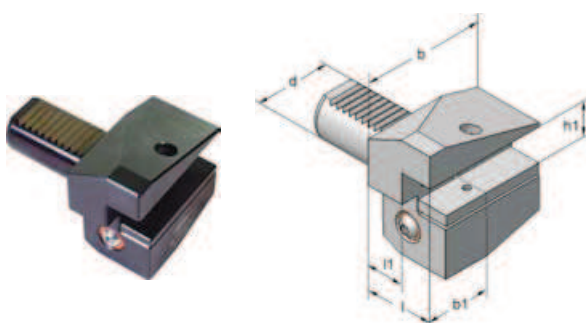

Art.-Nr.	Typ	d	b	b1	h1	l	l1
16.12.080	B4-16x12x24	16	42	23	12	24	13
20.16.080	B4-20x16x30	20	55	30	16	30	16
25.16.080	B4-25x16x30	25	55	30	16	30	16
30.20.080	B4-30x20x40	30	70	35	20	40	22
40.25.080	B4-40x25x44	40	85	42,5	25	44	22
50.32.080	B4-50x32x55	50	100	50	32	55	30
60.32.080	B4-60x32x55	60	125	62,5	32	60	30
INCH							
310206	B4-30x3/4"x40	30	70	35	3/4"	40	22
410206	B4-40x1" x44	40	85	42,5	1"	44	22
510206	B4-50x1 1/4"x55	50	100	50	1 1/4"	55	30

Radial-Werkzeughalter Form B5 lang
Radial toolholder form B5 long

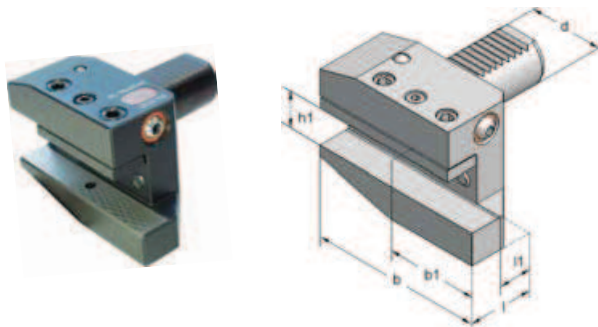

Art.-Nr.	Typ	d	b	b1	h1	l	l1
16.12.100	B5-16x12x24	16	58	39	12	24	13
20.16.100	B5-20x16x30	20	75	50	16	30	16
30.20.100	B5-30x20x40	30	100	65	20	40	22
30.25.100	B5-30x25x44	30	100	65	25	44	22
40.25.100	B5-40x25x44	40	108	66	25	44	22
50.32.100	B5-50x32x55	50	130	80	32	55	30
60.32.100	B5-60x32x55	60	145	82	32	60	30
INCH							
311206	B5-30x3/4"x40	30	100	65	3/4"	40	22
411206	B5-40x1" x44	40	108	66	1"	44	22
511206	B5-50x1 1/4"x55	50	130	80	1 1/4"	55	30

Radial-Werkzeughalter Form B6 lang
Radial toolholder form B6 long

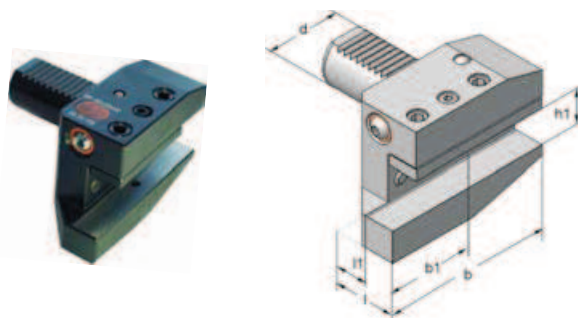

Art.-Nr.	Typ	d	b	b1	h1	l	l1
16.12.130	B6-16x12x24	16	58	39	12	24	13
20.16.130	B6-20x16x30	20	75	50	16	30	16
30.20.130	B6-30x20x40	30	100	65	20	40	22
40.25.130	B6-40x25x44	40	108	66	25	44	22
50.32.130	B6-50x32x55	50	130	80	32	55	30
60.32.130	B6-60x32x55	60	145	82	32	60	30
INCH							
312206	B6-30x3/4"x40	30	100	65	3/4"	40	22
412206	B6-40x1" x44	40	108	66	1"	44	22
512206	B6-50x1 1/4"x55	50	130	80	1 1/4"	55	30

Radial-Werkzeughalter Form B7 lang
Radial toolholder form B7 long

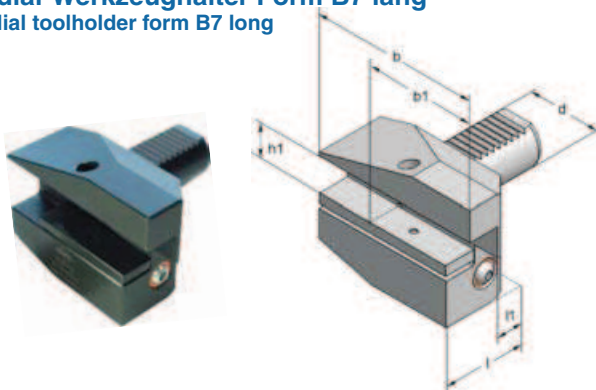

Art.-Nr.	Typ	d	b	b1	h1	l	l1
16.12.110	B7-16x12x24	16	58	39	12	24	13
20.16.110	B7-20x16x30	20	75	50	16	30	16
30.20.110	B7-30x20x40	30	100	65	20	40	22
40.25.110	B7-40x25x44	40	108	66	25	44	22
50.32.110	B7-50x32x55	50	130	80	32	55	30
60.32.110	B7-60x32x55	60	145	82	32	60	30
INCH							
313206	B7-30x3/4"x40	30	100	65	3/4"	40	22
413206	B7-40x1" x44	40	108	66	1"	44	22
513206	B7-50x1 1/4"x55	50	130	80	1 1/4"	55	30

Radial-Werkzeughalter Form B8 lang
Radial toolholder form B8 long

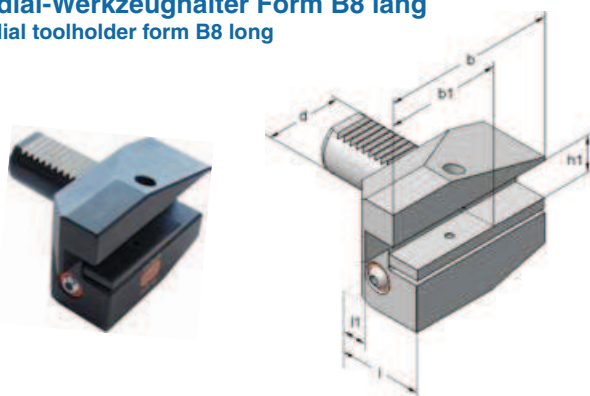

Art.-Nr.	Typ	d	b	b1	h1	l	l1
16.12.120	B8-16x12x24	16	58	39	12	24	13
20.16.120	B8-20x16x30	20	75	50	16	30	16
30.20.120	B8-30x20x40	30	100	65	20	40	22
40.25.120	B8-40x25x44	40	108	66	25	44	22
50.32.120	B8-50x32x55	50	130	80	32	55	30
60.32.120	B8-60x32x55	60	145	82	32	60	30
INCH							
314206	B8-30x3/4"x40	30	100	65	3/4"	40	22
414206	B8-40x1" x44	40	108	66	1"	44	22
514206	B8-50x1 1/4"x55	50	130	80	1 1/4"	55	30

Axial-Werkzeughalter Form C1
Axial toolholder form C1

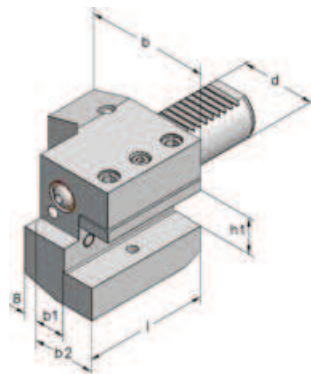

Art.-Nr.	Typ	d	b	b1	b2	h1	l
16.12.020	C1-16x12x 44	16	43	13,0	25	12	44
20.16.020	C1-20x16x 50	20	65	25,5	40	16	50
25.20.020	C1-25x20x 55	25	58	15,0	33	20	55
25.25.020	C1-25x25x 75	25	65	18,5	40	25	75
30.20.020	C1-30x20x 70	30	70	17,0	35	20	70
40.25.020	C1-40x25x 85	40	85	20,5	42,5	25	85
50.32.020	C1-50x32x100	50	100	25,5	50	32	100
60.32.020	C1-60x32x125	60	125	32,5	62,5	32	125
INCH							
303206	C1-30x3/4"x 70	30	70	17,0	35	3/4"	70
403206	C1-40x1" x 85	40	85	20,5	42,5	1"	85
503206	C1-50x1 1/4"x100	50	100	32,5	50	1 1/4"	100

Axial-Werkzeughalter Form C2
Axial toolholder form C2

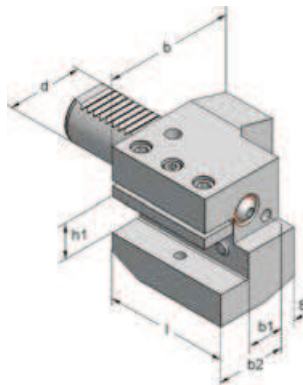

Art.-Nr.	Typ	d	b	b1	b2	h1	l
16.12.050	C2-16x12x 44	16	43	13,0	25	12	44
20.16.050	C2-20x16x 50	20	65	25,5	40	16	50
25.20.050	C2-25x20x 55	25	58	19,0	37	20	55
25.25.050	C2-25x25x 75	25	65	18,5	40	25	75
30.20.050	C2-30x20x 70	30	73	21,0	39	20	70
40.25.050	C2-40x25x 85	40	88	25,5	47,5	25	85
50.32.050	C2-50x32x100	50	105	30,0	55	32	100
60.32.050	C2-60x32x125	60	125	32,5	62,5	32	125
INCH							
304206	C2-30x3/4"x 70	30	73	21,0	39	3/4"	70
404206	C2-40x1" x 85	40	88	25,5	47,5	1"	85
504206	C2-50x1 1/4"x100	50	105	30,0	55	1 1/4"	100

Axial-Werkzeughalter Form C3
Axial toolholder form C3

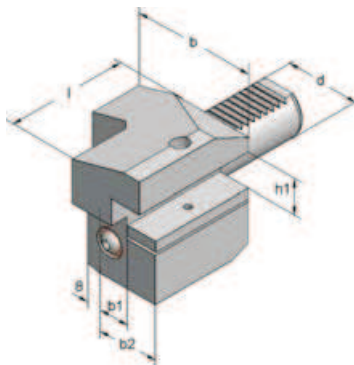

Art.-Nr.	Typ	d	b	b1	b2	h1	l
16.12.030	C3-16x12x 44	16	43	13,0	25	12	44
20.16.030	C3-20x16x 50	20	65	25,5	40	16	50
25.20.030	C3-25x20x 55	25	58	15,0	33	20	55
25.25.030	C3-25x25x 75	25	65	18,5	40	25	75
30.20.030	C3-30x20x 70	30	70	17,0	35	20	70
40.25.030	C3-40x25x 85	40	85	20,5	42,5	25	85
50.32.030	C3-50x32x100	50	100	25,5	50	32	100
60.32.030	C3-60x32x125	60	125	32,5	62,5	32	125
INCH							
305206	C3-30x3/4"x 70	30	70	20,5	35	3/4"	70
405206	C3-40x1" x 85	40	85	25,5	42,5	1"	85
505206	C3-50x1 1/4"x100	50	100	32,5	50	1 1/4"	100

Axial-Werkzeughalter Form C4
Axial toolholder form C4

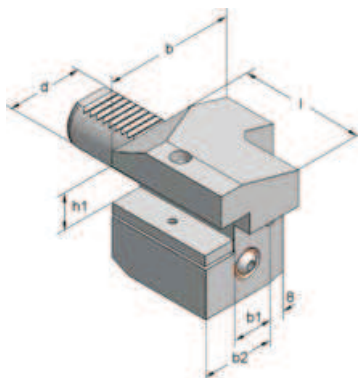

Art.-Nr.	Typ	d	b	b1	b2	h1	l
16.12.040	C4-16x12x 44	16	43	13,0	25	12	44
20.16.040	C4-20x16x 50	20	65	25,5	40	16	50
25.20.040	C4-25x20x 55	25	62	19,0	37	20	55
25.25.040	C4-25x25x 75	25	65	18,5	40	25	75
30.20.040	C4-30x20x 70	30	73	23,0	41	20	70
40.25.040	C4-40x25x 85	40	88	25,5	47,5	25	85
50.32.040	C4-50x32x100	50	105	30,0	55	32	100
60.32.040	C4-60x32x125	60	125	32,5	62,5	32	125
INCH							
306206	C4-30x3/4"x 70	30	73	23,0	41,0	3/4"	70
406206	C4-40x1" x 85	40	88	25,5	47,5	1"	85
506206	C4-50x1 1/4"x100	50	105	32,5	62,5	1 1/4"	100

Radial-Axial-Werkzeughalter Form B1/C1
Radial-axial toolholder form B1/C1

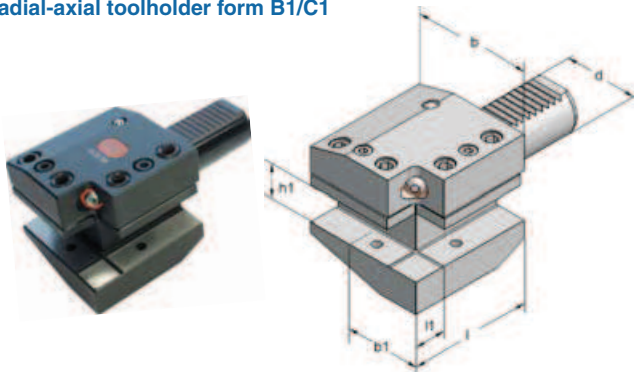

Art.-Nr.	Typ	d	b	b1	h1	l	l1
20.16.150	B1/C1-20x16x 50	20	65	40,0	16	50	14
30.20.150	B1/C1-30x20x 70	30	70	35,0	20	70	18
40.25.150	B1/C1-40x25x100	40	85	42,5	25	100	25
50.32.150	B1/C1-50x32x120	50	100	50,0	32	120	25
60.32.150	B1/C1-60x32x135	60	125	62,5	32	135	30

Radial-Axial-Werkzeughalter Form B2/C2
Radial-axial toolholder form B2/C2

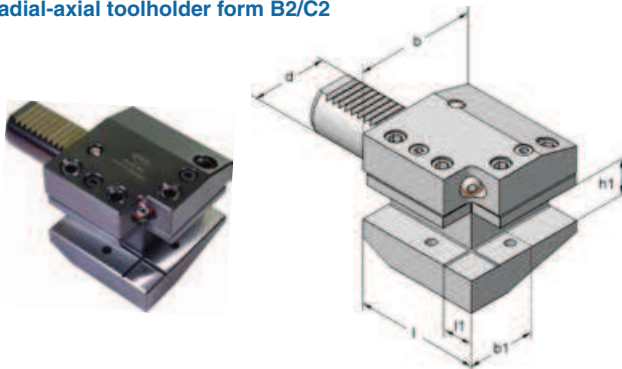

Art.-Nr.	Typ	d	b	b1	h1	l	l1
20.16.160	B2/C2-20x16x 50	20	65	40,0	16	50	14
30.20.160	B2/C2-30x20x 70	30	74	39,0	20	70	18
40.25.160	B2/C2-40x25x100	40	90	47,5	25	100	25
50.32.160	B2/C2-50x32x120	50	105	55,0	32	120	25
60.32.160	B2/C2-60x32x135	60	125	62,5	32	135	30

Radial-Axial-Werkzeughalter Form B3/C3
Radial-axial toolholder form B3/C3

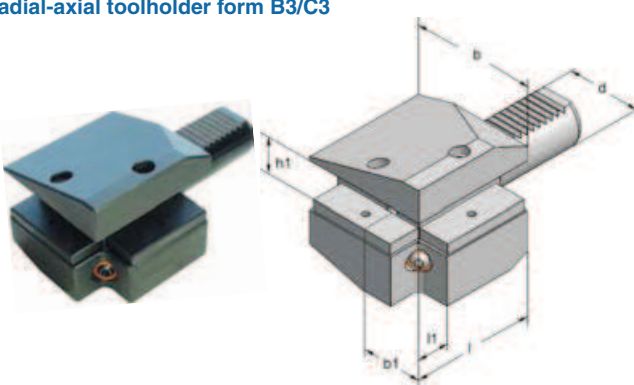

Art.-Nr.	Typ	d	b	b1	h1	l	l1
30.20.170	B3/C3-30x20x 70	30	70	35,0	20	70	18
40.25.170	B3/C3-40x25x100	40	85	42,5	25	100	25
50.32.170	B3/C3-50x32x120	50	100	50,0	32	120	25
60.32.170	B3/C3-60x32x135	60	125	62,5	32	135	30

Radial-Axial-Werkzeughalter Form B4/C4
Radial-axial toolholder form B4/C4

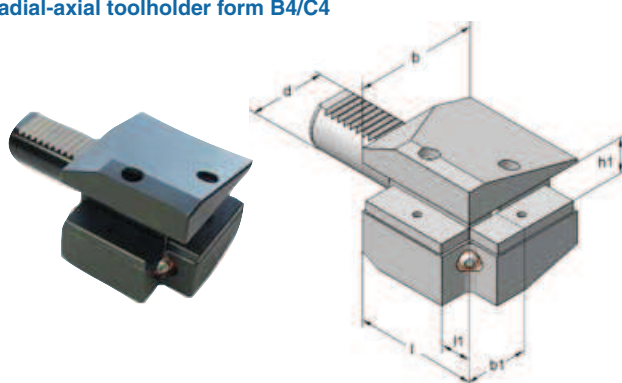

Art.-Nr.	Typ	d	b	b1	h1	l	l1
30.20.180	B4/C4-30x20x 70	30	74	39,0	20	70	18
40.25.180	B4/C4-40x25x100	40	85	42,5	25	100	25
50.32.180	B4/C4-50x32x120	50	105	55,0	32	120	25
60.32.180	B4/C4-60x32x135	60	125	62,5	32	135	30

Mehrfachaufnahme Form D1
Multiple toolholder form D1

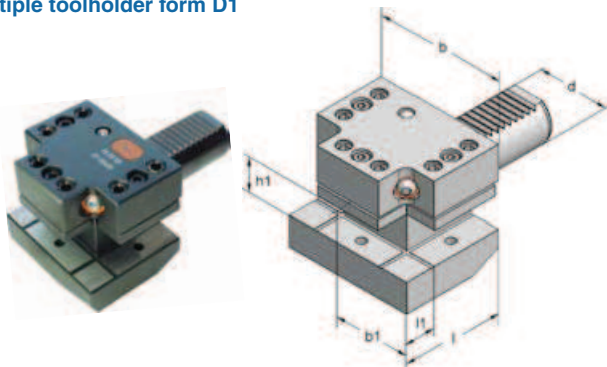

Art.-Nr.	Typ	d	b	b1	h1	l	l1
30.20.151	D1-30x20x 60	30	78	39,0	20	60	18
40.25.151	D1-40x25x 72	40	95	47,5	25	72	22
50.32.151	D1-50x32x 85	50	105	52,5	32	85	25
60.32.151	D1-60x32x110	60	115	57,5	32	110	25

Mehrfachaufnahme Form D2
Multiple toolholder form D2

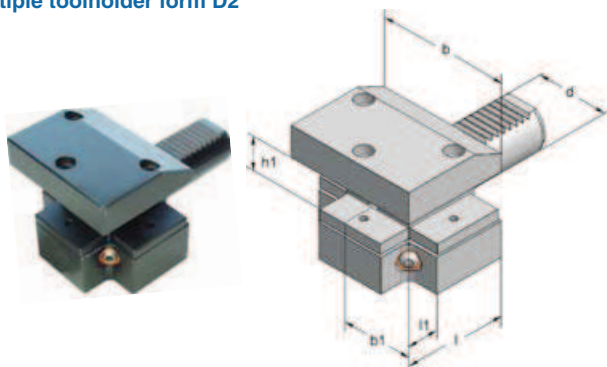

Art.-Nr.	Typ	d	b	b1	h1	l	l1
30.20.171	D2-30x20x 60	30	76	38,0	20	60	18
40.25.171	D2-40x25x 72	40	95	47,5	25	72	22
50.32.171	D2-50x32x 85	50	105	52,5	32	85	25
60.32.171	D2-60x32x110	60	115	57,5	32	110	25

Werkzeughalter-Rohling Form A1
Toolholder blank form A1

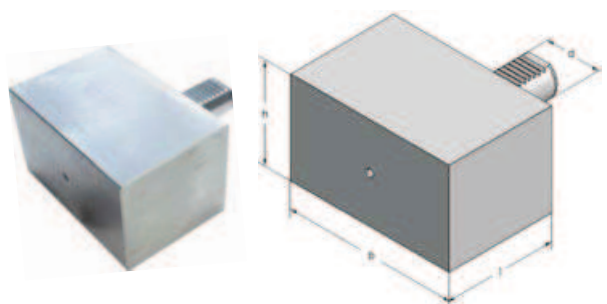

Art.-Nr.	Typ	d	b	h	l
20.050.001	A1-20x 60	20	68	60	60
25.075.001	A1-25x 75	25	100	60	75
30.085.001	A1-30x 85	30	130	76	85
40.100.001	A1-40x100	40	151	96	100
50.125.001	A1-50x125	50	160	120	125
60.160.001	A1-60x160	60	165	125	160

Werkzeughalter-Rohling Form A2
Toolholder blank form A2

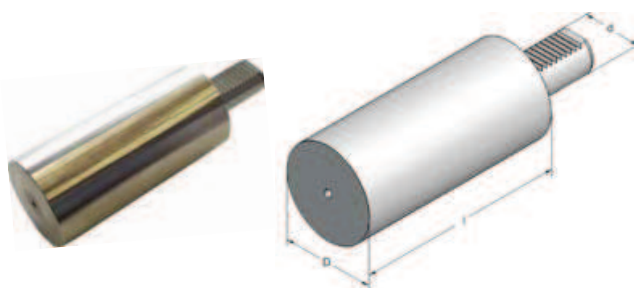

Art.-Nr.	Typ	d	D	l
20.070.010	A2-20x 70	20	49	70
25.080.010	A2-25x 80	25	58	80
30.150.010	A2-30x150	30	68	150
40.180.010	A2-40x180	40	83	180
40.400.010	A2-40x400	40	83	400
50.210.010	A2-50x210	50	98	210
60.240.010	A2-60x240	60	123	240

Bohrerhalter für U-Bohrer Form E1
Holder for T-max U-drills form E1

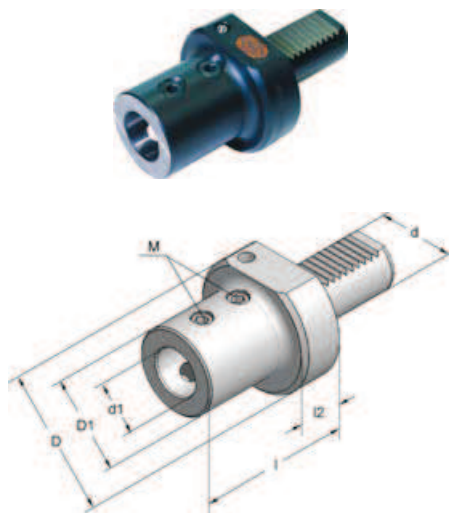

l1 Bohrungstiefe l1 drill depth

Art.-Nr.	Typ	d	d1	D	D1	l	l1	l2	Art.Nr. M
20.16.220	E1-20x16x 60	20	16	50	34	60	54	18	114100
20.20.220	E1-20x20x 60	20	20	50	40	60	54	18	114100
20.25.220	E1-20x25x 66	20	25	50	45	66	59	18	122100
25.16.220	E1-25x16x 60	25	16	58	34	60	54	18	114100
25.20.220	E1-25x20x 60	25	20	58	40	60	54	18	114100
25.25.220	E1-25x25x 66	25	25	58	45	66	59	18	122100
30.16.220	E1-30x16x 66	30	16	68	34	66	54	22	114100
30.20.220	E1-30x20x 66	30	20	68	40	66	54	22	114100
30.25.220	E1-30x25x 71	30	25	68	45	71	59	22	122100
30.32.220	E1-30x32x 75	30	32	68	52	75	63	22	122100
30.40.220	E1-30x40x 80	30	40	68	60	80	73	22	144100
40.16.220	E1-40x16x 66	40	16	83	34	66	54	22	114100
40.20.220	E1-40x20x 66	40	20	83	40	66	54	22	114100
40.25.220	E1-40x25x 71	40	25	83	45	71	59	22	122100
40.32.220	E1-40x32x 75	40	32	83	52	75	63	22	122100
40.40.220	E1-40x40x 85	40	40	83	60	85	73	22	144100
40.50.220	E1-40x50x 95	40	50	83	70	95	83	22	144100
50.20.220	E1-50x20x 66	50	20	98	40	66	54	30	114100
50.25.220	E1-50x25x 71	50	25	98	45	71	59	30	122100
50.32.220	E1-50x32x 75	50	32	98	52	75	63	30	122100
50.40.220	E1-50x40x 85	50	40	98	60	85	73	30	144100
50.50.220	E1-50x50x100	50	50	98	70	95	83	30	144100
60.20.220	E1-60x20x 66	60	20	123	40	66	54	30	114100
60.25.220	E1-60x25x 71	60	25	123	45	71	59	30	122100
60.32.220	E1-60x32x 75	60	32	123	52	75	63	30	122100
60.40.220	E1-60x40x 85	60	40	123	60	85	73	30	144100
60.50.220	E1-60x50x 95	60	50	123	70	95	83	30	144100

Bohrerhalter Whistle-Notch E1
Drill holder Whistle-Notch E1

Kühlmittelezufuhr intern + extern
 Coolant supply internal + external

DIN 1835 Form E

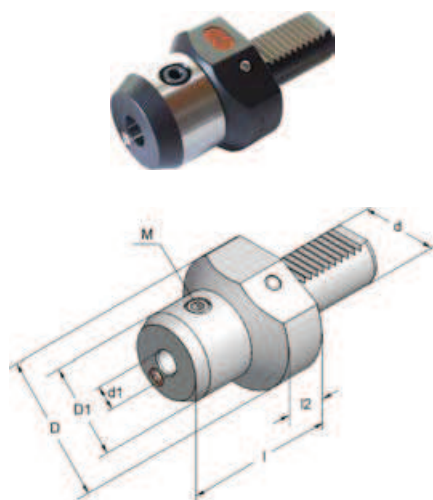

l1 Bohrungstiefe l1 drill depth

Art.-Nr.	Typ	d	d1	D	D1	l	l1	l2	Art.Nr. M
20.06.221	E1-20x06Ex60	20	6	50	35	60	36	18	147100
20.08.221	E1-20x08Ex60	20	8	50	35	60	36	18	148100
20.10.221	E1-20x10Ex60	20	10	50	35	60	40	18	149100
20.12.221	E1-20x12Ex60	20	12	50	44	60	45	18	150100
20.14.221	E1-20x14Ex60	20	14	50	44	60	45	18	150100
20.16.221	E1-20x16Ex60	20	16	50	50	60	48	-	151100
20.18.221	E1-20x18Ex60	20	18	50	50	60	48	-	151100
20.20.221	E1-20x20Ex60	20	20	50	50	60	50	-	152100
30.06.221	E1-30x06Ex67	30	6	68	35	67	36	22	147100
30.08.221	E1-30x08Ex67	30	8	68	35	67	36	22	148100
30.10.221	E1-30x10Ex67	30	10	68	35	67	40	22	149100
30.12.221	E1-30x12Ex67	30	12	68	44	67	45	22	150100
30.14.221	E1-30x14Ex67	30	14	68	44	67	45	22	150100
30.16.221	E1-30x16Ex67	30	16	68	52	67	48	22	151100
30.18.221	E1-30x18Ex67	30	18	68	52	67	48	22	151100
30.20.221	E1-30x20Ex67	30	20	68	52	67	50	22	152100
40.06.221	E1-40x06Ex67	40	6	83	35	67	36	22	147100
40.08.221	E1-40x08Ex67	40	8	83	35	67	36	22	148100
40.10.221	E1-40x10Ex67	40	10	83	35	67	40	22	149100
40.12.221	E1-40x12Ex67	40	12	83	44	67	45	22	150100
40.14.221	E1-40x14Ex67	40	14	83	44	67	45	22	150100
40.16.221	E1-40x16Ex67	40	16	83	52	67	48	22	151100
40.18.221	E1-40x18Ex67	40	18	83	52	67	48	22	151100
40.20.221	E1-40x20Ex67	40	20	83	52	67	50	22	152100

Bohrstangenhalter Form E2
Boring bar holder form E2

Kühlmittelzufuhr intern + extern
 Coolant supply internal + external

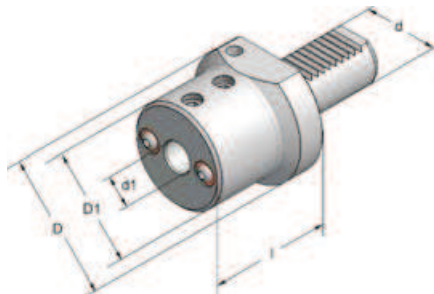

l1 Bohrungstiefe l1 drill depth

Art.-Nr.	Typ	d	d1	D	D1	l	l1
16.06.290	E2-16x06x44	16	6	40	40	44	39
16.08.290	E2-16x08x44	16	8	40	40	44	39
16.10.290	E2-16x10x44	16	10	40	40	44	39
16.12.290	E2-16x12x44	16	12	40	40	44	39
16.16.290	E2-16x16x44	16	16	40	40	44	39
20.06.290	E2-20x06x50	20	6	50	40	50	84
20.08.290	E2-20x08x50	20	8	50	40	50	84
20.10.290	E2-20x10x50	20	10	50	40	50	45
20.12.290	E2-20x12x50	20	12	50	40	50	45
20.16.290	E2-20x16x50	20	16	50	44	50	45
20.20.290	E2-20x20x50	20	20	50	49	50	45
20.25.290	E2-20x25x50	20	25	54	54	50	45
25.06.290	E2-25x06x50	25	6	58	40	50	84
25.08.290	E2-25x08x50	25	8	58	40	50	84
25.10.290	E2-25x10x50	25	10	58	40	50	84
25.12.290	E2-25x12x50	25	12	58	40	50	45
25.16.290	E2-25x16x50	25	16	58	40	50	45
25.20.290	E2-25x20x50	25	20	58	58	50	45
25.25.290	E2-25x25x50	25	25	58	58	50	45
30.06.290	E2-30x06x60	30	6	68	50	60	106
30.08.290	E2-30x08x60	30	8	68	50	60	106
30.10.290	E2-30x10x60	30	10	68	50	60	106
30.12.290	E2-30x12x60	30	12	68	50	60	106
30.16.290	E2-30x16x60	30	16	68	55	60	106
30.20.290	E2-30x20x60	30	20	68	55	60	55
30.25.290	E2-30x25x60	30	25	68	55	60	55
30.30.290	E2-30x30x60	30	30	68	68	60	57
30.32.290	E2-30x32x60	30	32	68	68	60	57
30.40.290	E2-30x40x60	30	40	74	74	75	66
40.08.290	E2-40x08x75	40	8	83	50	75	130
40.10.290	E2-40x10x75	40	10	83	50	75	130
40.12.290	E2-40x12x75	40	12	83	50	75	130
40.16.290	E2-40x16x75	40	16	83	55	75	130
40.20.290	E2-40x20x75	40	20	83	55	75	130
40.25.290	E2-40x25x75	40	25	83	60	75	66
40.30.290	E2-40x30x75	40	30	83	72	75	66
40.32.290	E2-40x32x75	40	32	83	72	75	66
40.40.290	E2-40x40x75	40	40	83	83	85	73
50.12.290	E2-50x12x90	50	12	98	56	90	156
50.16.290	E2-50x16x90	50	16	98	56	90	156
50.20.290	E2-50x20x90	50	20	98	56	90	156
50.25.290	E2-50x25x90	50	25	98	65	90	156
50.30.290	E2-50x30x90	50	30	98	68	90	110
50.32.290	E2-50x32x90	50	32	98	68	90	110
50.40.290	E2-50x40x90	50	40	98	80	90	81
50.50.290	E2-50x50x90	50	50	98	90	95	83

Bohrstangenhalter Form E2
Boring bar holder form E2

Kühlmittelzufuhr intern + extern
 Coolant supply internal + external

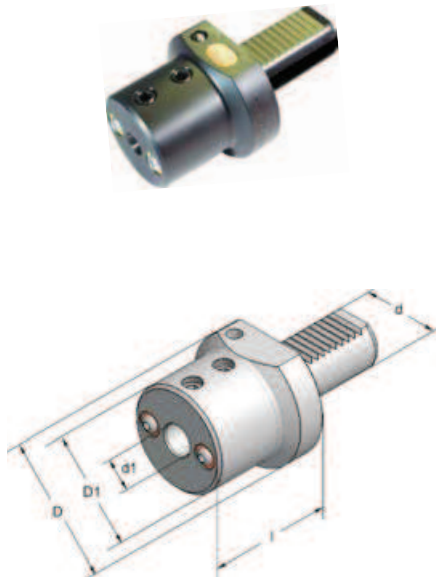

l1 Bohrungstiefe l1 drill depth

Art.-Nr.	Typ	d	d1	D	D1	l	l1
60.12.290	E2-60x12x90	60	12	123	52	90	174
60.16.290	E2-60x16x90	60	16	123	60	90	174
60.20.290	E2-60x20x90	60	20	123	60	90	174
60.25.290	E2-60x25x90	60	25	123	65	90	174
60.30.290	E2-60x30x90	60	30	123	70	90	172
60.32.290	E2-60x32x90	60	32	123	70	90	172
60.40.290	E2-60x40x90	60	40	123	80	90	110
60.50.290	E2-60x50x90	60	50	123	90	100	88
60.60.290	E2-60x60x90	60	60	123	100	100	88
INCH							
329206	E2-30x3/8"x60	30	3/8"	68	50	60	106
330206	E2-30x1/2"x60	30	1/2"	68	50	60	106
331206	E2-30x5/8"x60	30	5/8"	68	55	60	106
332206	E2-30x3/4"x60	30	3/4"	68	55	60	55
333206	E2-30x1" x60	30	1"	68	55	60	55
334206	E2-30x1 1/4"x65	30	1 1/4"	68	68	65	57
335206	E2-30x1 1/2"x75	30	1 1/2"	74	74	75	65
429206	E2-40x3/8"x75	40	3/8"	83	50	75	130
430206	E2-40x1/2"x75	40	1/2"	83	50	75	130
431206	E2-40x5/8"x75	40	5/8"	83	55	75	130
432206	E2-40x3/4"x75	40	3/4"	83	55	75	130
433206	E2-40x1" x75	40	1"	83	60	75	66
434206	E2-40x1 1/4"x75	40	1 1/4"	83	72	75	66
435206	E2-40x1 1/2"x85	40	1 1/2"	83	72	85	73
436206	E2-40x1 3/4"x85	40	1 3/4"	83	83	85	73
530206	E2-50x1/2"x90	50	1/2"	98	56	90	156
531206	E2-50x5/8"x90	50	5/8"	98	56	90	156
532206	E2-50x3/4"x90	50	3/4"	98	56	90	156
533206	E2-50x1" x90	50	1"	98	65	90	156
534206	E2-50x1 1/4"x90	50	1 1/4"	98	68	90	110
535206	E2-50x1 1/2"x90	50	1 1/2"	98	68	90	110
536206	E2-50x1 3/4"x90	50	1 3/4"	98	80	90	81
537206	E2-50x2" x95	50	2"	98	90	95	83

Bohrstangenhalter Form E7 / E8
Boring bar holder form E7 / E8

Kühlmittelzufuhr intern + extern
 Coolant supply internal + external

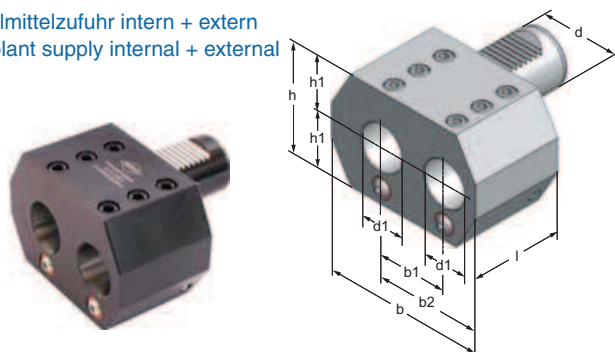

Art.-Nr.	Typ	d	d1	b	b1	b2	h	l
30.25.2903	E7+E8-30x25x56	30	25	95	45	65	64	56
40.32.2903	E7+E8-40x32x66	40	32	115	50	75	78	66
50.50.2903	E7+E8-50x50x90	50	50	154	70	105	98	90

VDI-Schaft mit Doppelverzahnung
 VDI-Shank with double toothting

Bohrstangenhalter geschlitzt
Boring bar holder slotted

Kühlmittelzufuhr intern + extern
 Coolant supply internal + external

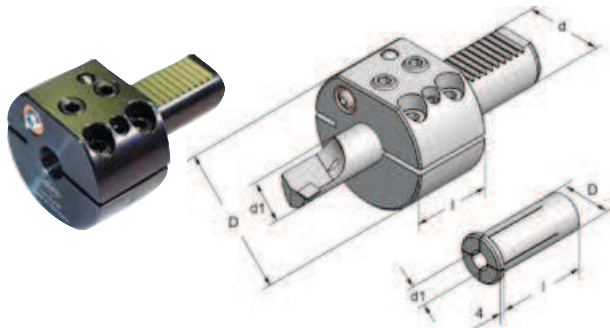

I1 Bohrungstiefe I1 drill depth

Art.-Nr.	Typ	d	d1	D	I	I1
30.16.230	E2-30x16x42	30	16	68	42	88
30.20.230	E2-30x20x42	30	20	68	42	88
40.16.230	E2-40x16x46	40	16	83	46	100
40.20.230	E2-40x20x46	40	20	83	46	100
40.25.230	E2-40x25x46	40	25	83	46	100
40.32.230	E2-40x32x90	40	32	83	90	83
50.20.230	E2-50x20x55	50	20	98	55	125
50.25.230	E2-50x25x55	50	25	98	55	125
50.32.230	E2-50x32x55	50	32	98	55	125
60.25.230	E2-60x25x60	60	25	123	60	145
60.32.230	E2-60x32x60	60	32	123	60	145
60.40.230	E2-60x40x60	60	40	123	60	145
203201	Reduzierung		8	20	51	
203202	Reduzierung		10	20	51	
203203	Reduzierung		12	20	51	
203205	Reduzierung		16	20	51	

Bohrerhalter für MK-Werkzeuge Form F1
Holder for M.T. Shanks form F1

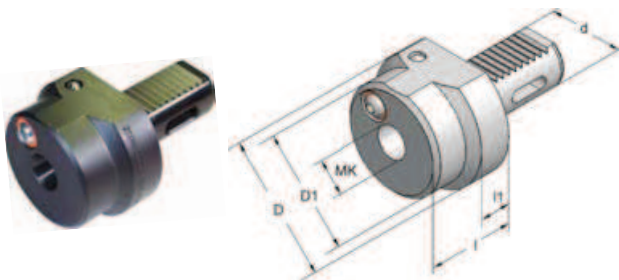

Art.-Nr.	Typ	d	MK	D	D1	I	I1
20.01.200	F1-20xMK1x22	20	1	50	-	22	-
30.01.200	F1-30xMK1x25	30	1	68	52	25	25
30.02.200	F1-30xMK2x42	30	2	68	58	42	25
30.03.200	F1-30xMK3x66	30	3	68	68	66	-
40.01.200	F1-40xMK1x25	40	1	83	-	25	-
40.02.200	F1-40xMK2x34	40	2	83	58	34	25
40.03.200	F1-40xMK3x58	40	3	83	64	58	25
40.04.200	F1-40xMK4x86	40	4	83	72	86	25
50.02.200	F1-50xMK2x25	50	2	98	-	25	-
50.03.200	F1-50xMK3x42	50	3	98	64	42	25
50.04.200	F1-50xMK4x71	50	4	98	72	71	25
60.02.200	F1-60xMK2x27	60	2	123	-	27	-
60.03.200	F1-60xMK3x27	60	3	123	-	27	-
60.04.200	F1-60xMK4x55	60	4	123	72	55	25
60.05.200	F1-60xMK5x94	60	5	123	90	94	30

Spannzangenhalter Form E4
für Spannzangen ER/DIN 6499
Collet chuck form E4 for collets ER/DIN 6499

Kühlmittelzufuhr intern + extern
 Coolant supply internal + external

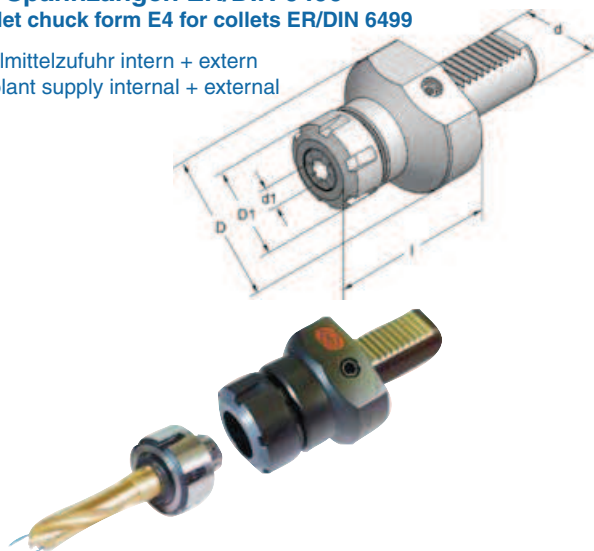

Spannmuttern GMGC und Dichtscheiben siehe Seite 79
 Locknuts GMGC and sealing rings see page 79

Art.-Nr.	Typ	d	d1	D	D1	I	ER/ESX
16.10.330	E4-16x10x50	16	1-10	40	28	50	16
16.16.330	E4-16x16x50	16	1-16	40	42	50	25
20.10.330	E4-20x10x55	20	1-10	50	28	55	16
20.16.330	E4-20x16x55	20	1-16	50	42	55	25
20.20.330	E4-20x20x55	20	2-20	50	50	55	32
25.16.330	E4-25x16x55	25	1-16	58	42	55	25
25.20.330	E4-25x20x55	25	2-20	58	50	55	32
30.16.330	E4-30x16x75	30	1-16	68	42	75	25
30.16.331	E4-30x16x55	30	1-16	68	42	55	25
30.20.330	E4-30x20x75	30	2-20	68	50	75	32
30.20.331	E4-30x20x55	30	2-20	68	50	55	32
30.26.330	E4-30x26x75	30	3-30	68	63	75	40
40.16.330	E4-40x16x75	40	1-16	83	42	75	25
40.20.330	E4-40x20x75	40	2-20	83	50	75	32
40.26.330	E4-40x26x75	40	3-30	83	63	75	40
50.20.330	E4-50x20x90	50	2-20	98	50	90	32
50.26.330	E4-50x26x90	50	3-30	98	63	90	40
50.34.330	E4-50x34x90	50	6-34	98	78	90	50
60.26.330	E4-60x26x90	60	3-30	123	63	90	40
60.34.330	E4-60x34x99	60	6-34	123	78	99	50

**Spannzangenhalter E3
für Spannzangen DIN 6388**
Collet chuck E3 for collets DIN 6388

Kühlmittelzufuhr intern + extern
 Coolant supply internal + external

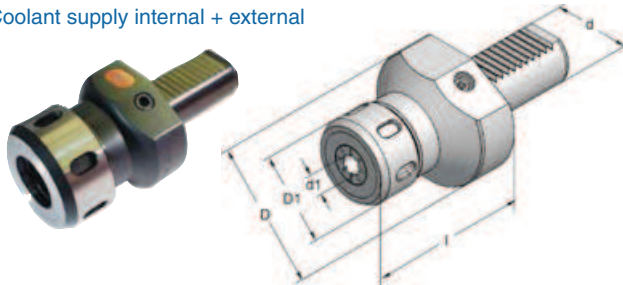

Art.-Nr.	Typ	d	d1	D	D1	l
20.16.320	E3-20x16x55	20	2-16	50	40	55
30.25.320	E3-30x25x75	30	2-25	68	60	75
40.25.320	E3-40x25x75	40	2-25	83	60	75
40.32.320	E3-40x32x90	40	4-32	83	72	90
50.32.320	E3-50x32x90	50	4-32	98	72	90
60.32.320	E3-60x32x90	60	4-32	123	72	90

Spannmuttern GMGC und Dichtscheiben siehe Seite 79
 Locknuts GMGC and sealing rings see page 79

Schnellspann-Bohrfutter für Links- und Rechtslauf
Quick locking drill chuck for left and right rotation

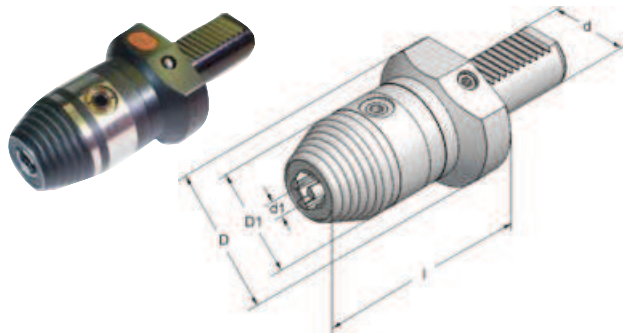

Art.-Nr.	Typ	d	d1	D	D1	l
16.06.08	16x1-8x68	16	1-8	44	36	68
20.06.08	20x1-8x68	20	1-8	50	36	68
25.06.08	25x1-8x68	25	1-8	58	36	68
30.06.13	30x1-13x96	30	1-13	68	50	96
40.06.13	40x1-13x96	40	1-13	83	50	96
40.06.16	40x3-16x96	40	3-16	83	57	96
50.06.16	50x3-16x96	50	3-16	98	57	96
60.06.16	60x3-16x96	60	3-16	123	57	96

Schnellspann-Bohrfutter mit Zylinderschaft
Quick locking drill chuck cyl. shank

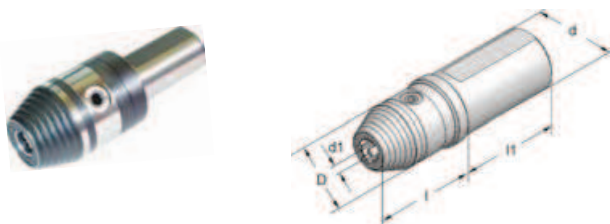

Art.-Nr.	Typ	d	d1	D1	l	l1
25.08.13	zyl.25x1-13x74	25	1-13	50	74	55
30.08.13	zyl.30x1-13x74	30	1-13	50	74	55
32.08.13	zyl.32x1-13x74	32	1-13	50	74	55
40.08.13	zyl.40x1-13x74	40	1-13	50	74	68
40.08.16	zyl.40x3-16x74	40	3-16	57	74	68
50.08.13	zyl.50x1-13x74	50	1-13	50	74	88
50.08.16	zyl.50x3-16x74	50	3-16	57	74	88

**Spannzangenfutter zyl.
für Spannzangen ER/DIN 6499**
Collet chuck cyl. for collets ER/DIN 6499

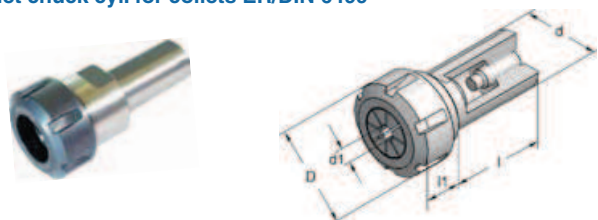

Art.-Nr.	Typ	d	d1	D	l	l1
100102	ø08x 56xER11M	8	1-7	16	56	26
101102	ø12x 80xER16M	12	1-10	22	80	37
102102	ø16x150xER16M	16	1-10	22	150	30
103102	ø19,05x56xER25	19,05	2-16	42	56	46
104102	ø20 x50xER25	20	2-16	42	50	46
105102	ø20 x100xER25	20	2-16	42	100	46
106102	ø25 x 50xER25	25	2-16	42	50	40
107102	ø25 x150xER25	25	2-16	42	150	40
108102	ø25,4x 50xER25	25,40	2-16	42	50	40
109102	ø25,4x 50xER32	25,40	3-20	50	50	51
110102	ø31,75x50xER25	31,75	2-16	42	50	30
111102	ø31,75x50xER32	31,75	3-20	50	50	35
112102	ø32 x 56xER25	32	2-16	42	56	36
113102	ø32 x 56xER32	32	3-20	50	56	35
114102	ø32 x150xER25	32	2-16	50	150	30
115102	ø32 x150xER32	32	3-20	50	150	35
116102	ø32 x 56xER40	32	3-30	63	56	60
117102	ø40 x 66xER32	40	3-20	50	66	33
118102	ø40 x 66xER40	40	3-30	63	66	55

Pendelhalter, achsparallel ausgleichend einstellbar mit auswechselbaren Einsätzen
Floating holder, axially parallel compensating, adjustable with inserts

Kühlmittelzufuhr intern + extern
 Coolant supply internal + external



Art.-Nr.	Typ	d	D	D1	l
16.70.350	16xER16x67	16	50	50	67
20.70.350	20xER16x65	20	50	50	65
25.70.350	25xER16x65	25	58	58	65
30.70.350	ohne Einsatz	30	68	64	75
40.70.350	ohne Einsatz	40	83	64	75
50.70.350	ohne Einsatz	50	98	64	75

Abbildung zeigt: Ausführung montiert mit Einsatz 101101 ER25
 Picture shows: this type is mounted with insert 101101 ER25
 VDI16+20+25 incl. Einsatz ER16/426E
 VDI16+20+25 incl. insert ER16/426E

Art.-Nr.	Typ	d1
101101	Einsatz ER25	1-16
102101	Einsatz DA180	2-20
103101	Einsatz B-12	12
104101	Einsatz B-15	15
105101	Einsatz B-16	16
106101	Einsatz B-18	18
107101	Einsatz B-20	20
108101	Einsatz B-25	25
109101	Einsatz MK2	MK2

Mitlaufender Anschlag längseinstellbar
Rotary stop with interchangeable heads

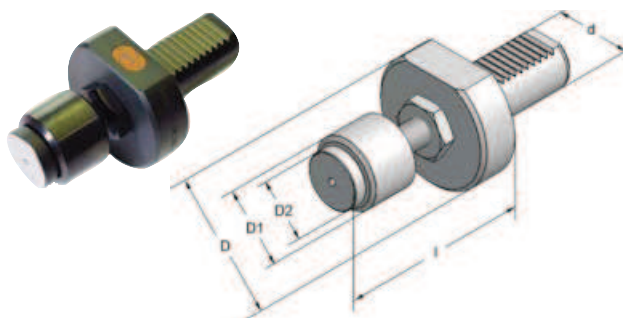

Art.-Nr.	Typ	d	D	D1	D2	l
20.30.355	VDI 20	20	50	38	25	55
25.30.355	VDI 25	25	58	38	25	55
30.38.355	VDI 30	30	68	38	25	65-100
40.60.355	VDI 40	40	83	60	40	80-150
50.60.355	VDI 50	50	98	60	40	80-150

Mitlaufende Zentrierspitze gefedert
Driver centering point spring mounted

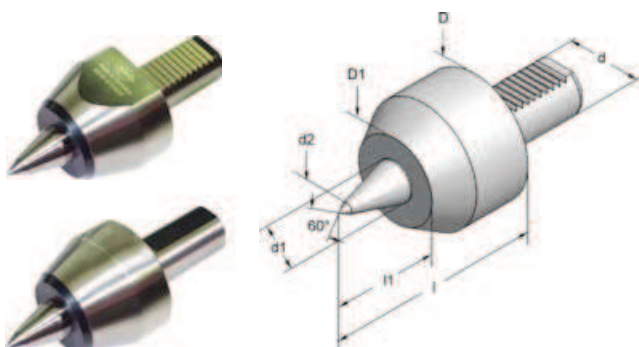

Art.-Nr.	Typ	d	d1	d2	D	D1	l	l1
4720020	VDI20x60°x 73	20	18	6	50	41	73	42
4720025	VDI25x60°x 73	25	18	8	58	41	73	42
4720030	VDI30x60°x 88	30	22	11	68	47	88	51
4720040	VDI40x60°x111	40	32	16	83	56	111	63
25.10.6000	zyl.25x60°x 86	25	22	11	54	44	86	36

Gewindeschneidfutter mit elastischem Längenausgleich auf Zug mit innerer Kühlmittelzufuhr
Auto tapper with flexible position differential with internal coolant

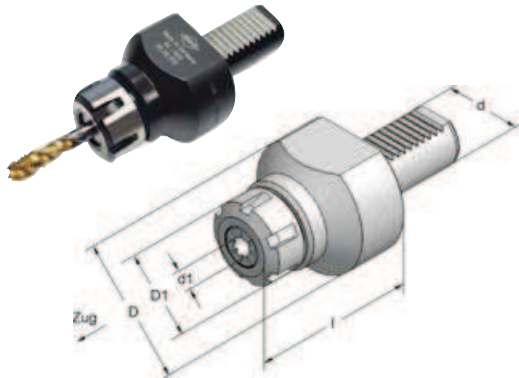

Art.-Nr.	Typ	d	d1	l	Zug	D	D1
16.12.370	16xER16x60	16	1-10 / M3-M12	60	12	40	28
20.12.370	20xER16x60	20	1-10 / M3-M12	60	12	50	28
20.20.370	20xER25x85	20	2-16 / M4-M20	85	15	50	42
25.12.370	25xER16x60	25	1-10 / M3-M12	60	12	58	28
25.20.370	25xER25x79	25	2-16 / M4-M20	79	15	58	42
30.20.370	30xER25x75	30	2-16 / M4-M20	75	15	68	42
30.20.370*	30xER32x92	30	3-20 / M4-M24	92	15	68	50
40.20.370	40xER25x75	40	2-16 / M4-M20	75	15	83	42
40.20.370*	40xER32x92	40	3-20 / M4-M24	92	15	83	50
40.33.370	40xER40x98	40	4-30 / M8-M33	98	20	83	63
50.20.370	50xER25x75	50	2-16 / M4-M20	75	15	98	42
50.33.370	50xER40x98	50	4-30 / M8-M33	98	20	98	63
60.33.370	60xER40x75	60	4-30 / M8-M33	75	20	125	63

mit innerer Kühlmittelzufuhr
 with internal coolant

Gewindeschneidfutter mit zylindrischer Aufnahme
Auto tapper with cylindric shank

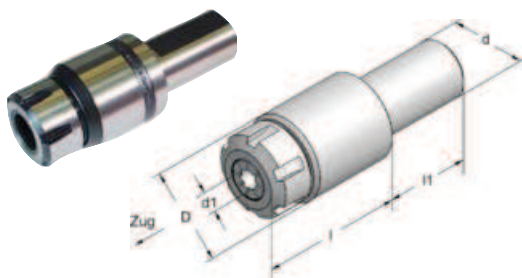

Art.-Nr.	Typ	d	d1	l	Zug	D	l1
16.12.372	16xER16x60	16	1-10 / M3-M12	60	12	32	40
20.12.372	20xER16x60	20	1-10 / M3-M12	60	12	32	48
20.20.372	20xER25x75	20	2-16 / M4-M20	75	15	45	48
25.20.372	25xER25x75	25	2-16 / M4-M20	75	15	45	48
30.20.372	30xER25x75	30	2-16 / M4-M20	75	15	45	55
32.20.372	32xER25x75	32	2-16 / M4-M20	75	15	49	58
40.20.372	40xER25x60	40	2-16 / M4-M20	60	15	49	68
25.20.375	25xER25x75	25	2-16 / M4-M20	75	15	53	54
32.20.375	32xER25x75	32	2-16 / M4-M20	75	15	53	54

d1 1-10 Typ ER16 426E
 d1 2-16 Typ ER25 430E
 d1 3-20 Typ ER32 470E
 d1 4-30 Typ ER40 472E
 Typ .375 mit innerer Kühlmittelzufuhr
 Typ .375 with internal coolant

Einsatz für Schneideisen
Die housing insert



Art.-Nr.	Typ	d	D	l
153101	Ø16x16	16	28	6,0
154101	Ø16x20	20	32	7,5
155101	Ø16x25	25	37	9,5
156101	Ø16x30	30	42	11,0

Kontrolldorn
Test arbor

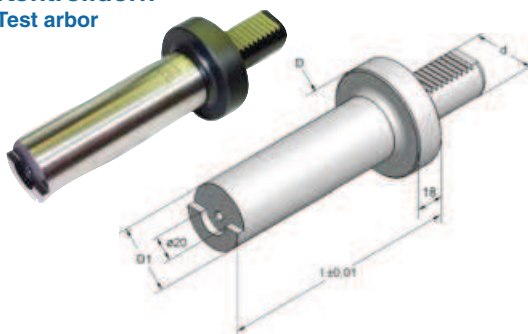

Art.-Nr.	Typ	d	D	D1	l
16.100.01	Ø16x40x100	16	40	40	100
20.100.01	Ø20x40x100	20	50	40	100
25.125.01	Ø25x40x125	25	58	40	125
30.150.01	Ø30x40x150	30	68	40	150
40.150.01	Ø40x40x150	40	83	40	150
50.200.01	Ø50x50x200	50	98	50	200
60.200.01	Ø60x50x200	60	125	50	200

in Holzetui / in wooden case

**Abstechmeisselhalter, höhenverstellbar
 $\pm 0,5\text{mm}$ rechts**
 Tool holder for cut off tools adjustable in height $\pm 0,5\text{mm}$ right

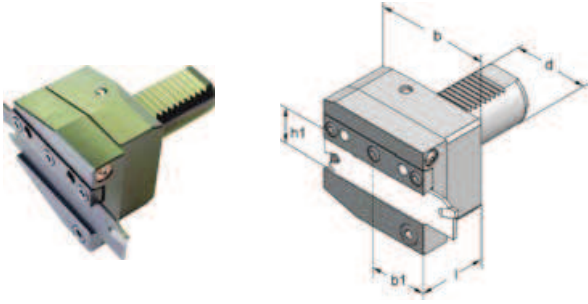

Art.-Nr.	Typ	d	b	b1	l	h1
30.26.480	30x26x50-r	30	65	35	50	26
30.32.480	30x32x50-r	30	65	35	50	32
40.26.480	40x26x50-r	40	85	42,5	50	26
40.32.480	40x32x50-r	40	85	42,5	50	32
50.26.480	50x26x50-r	50	100	50	50	26
50.32.480	50x32x50-r	50	100	50	50	32
60.32.480	60x32x60-r	60	100	62,5	60	32

**Abstechmeisselhalter, höhenverstellbar
 $\pm 0,5\text{mm}$ Überkopf rechts**
 Tool holder for cut off tools adjustable in height $\pm 0,5\text{mm}$ overhead right



Art.-Nr.	Typ	d	b	b1	l	h1
30.26.481	30x26x50-rük	30	65	35	50	26
30.32.481	30x32x50-rük	30	65	35	50	32
40.32.481	40x32x50-rük	40	85	42,5	50	32
50.32.481	50x32x50-rük	50	100	50	50	32

**Abstechmeisselhalter, höhenverstellbar
 $\pm 0,5\text{mm}$ links**
 Tool holder for cut off tools adjustable in height $\pm 0,5\text{mm}$ left



Art.-Nr.	Typ	d	b	b1	l	h1
30.26.482	30x26x50-l	30	65	35	50	26
30.32.482	30x32x50-l	30	65	35	50	32
40.26.482	40x26x50-l	40	85	42,5	50	26
40.32.482	40x32x50-l	40	85	42,5	50	32

Schutzstopfen Form Z2
 Blind tooling bore form Z2

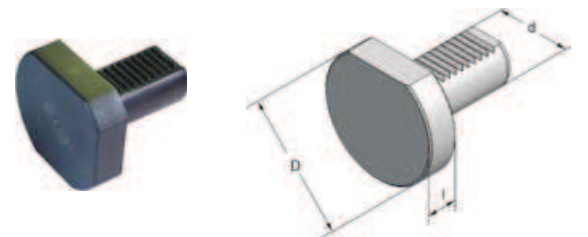

Art.-Nr.	Typ	d	D	l
16.00.500	Z2-16	16	40	16
20.00.500	Z2-20	20	50	16
25.00.500	Z2-25	25	58	16
30.00.500	Z2-30	30	68	20
40.00.500	Z2-40	40	83	20
50.00.500	Z2-50	50	98	20
60.00.500	Z2-60	60	123	20
30.00.500-S	Z2-30 Stahl	30	68	20
40.00.500-S	Z2-40 Stahl	40	83	20
50.00.500-S	Z2-50 Stahl	50	98	20
60.00.500-S	Z2-60 Stahl	60	123	20

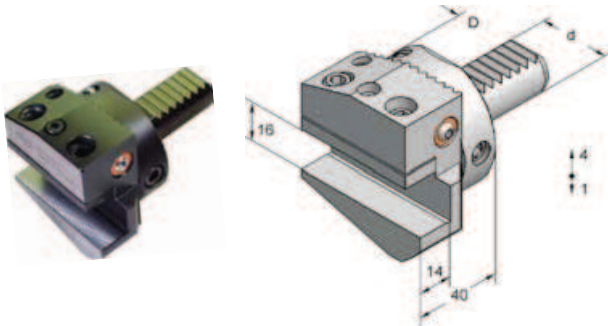
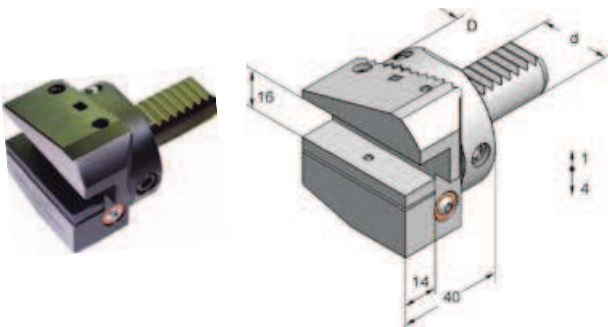
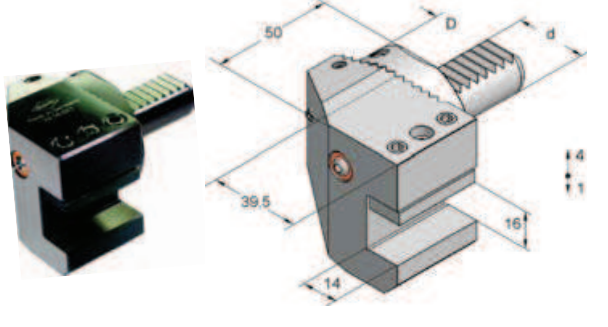
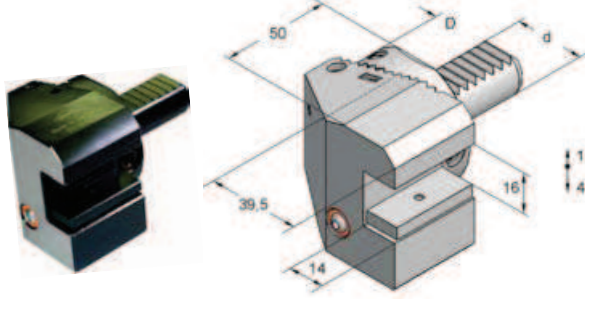
<p>Radial-Werkzeughalter Form B1 höhenverstellbar Radial toolholder Form B1 adjustable in height</p> 	<table border="1"> <thead> <tr> <th>Art.-Nr.</th> <th>Typ</th> <th>d</th> <th>D</th> </tr> </thead> <tbody> <tr> <td>20.16.061</td> <td>B1-20x16x40</td> <td>20</td> <td>50</td> </tr> <tr> <td>25.16.061</td> <td>B1-25x16x40</td> <td>25</td> <td>58</td> </tr> <tr> <td>30.16.061</td> <td>B1-30x16x40</td> <td>30</td> <td>68</td> </tr> </tbody> </table>	Art.-Nr.	Typ	d	D	20.16.061	B1-20x16x40	20	50	25.16.061	B1-25x16x40	25	58	30.16.061	B1-30x16x40	30	68
Art.-Nr.	Typ	d	D														
20.16.061	B1-20x16x40	20	50														
25.16.061	B1-25x16x40	25	58														
30.16.061	B1-30x16x40	30	68														
<p>Radial-Werkzeughalter Form B3 höhenverstellbar Radial toolholder Form B3 adjustable in height</p> 	<table border="1"> <thead> <tr> <th>Art.-Nr.</th> <th>Typ</th> <th>d</th> <th>D</th> </tr> </thead> <tbody> <tr> <td>20.16.071</td> <td>B3-20x16x40</td> <td>20</td> <td>50</td> </tr> <tr> <td>25.16.071</td> <td>B3-25x16x40</td> <td>25</td> <td>58</td> </tr> <tr> <td>30.16.071</td> <td>B3-30x16x40</td> <td>30</td> <td>68</td> </tr> </tbody> </table>	Art.-Nr.	Typ	d	D	20.16.071	B3-20x16x40	20	50	25.16.071	B3-25x16x40	25	58	30.16.071	B3-30x16x40	30	68
Art.-Nr.	Typ	d	D														
20.16.071	B3-20x16x40	20	50														
25.16.071	B3-25x16x40	25	58														
30.16.071	B3-30x16x40	30	68														
<p>Axial-Werkzeughalter Form C1 höhenverstellbar Axial toolholder Form C1 adjustable in height</p> 	<table border="1"> <thead> <tr> <th>Art.-Nr.</th> <th>Typ</th> <th>d</th> <th>D</th> </tr> </thead> <tbody> <tr> <td>20.16.021</td> <td>C1-20x16x50</td> <td>20</td> <td>50</td> </tr> <tr> <td>25.16.021</td> <td>C1-25x16x50</td> <td>25</td> <td>58</td> </tr> <tr> <td>30.16.021</td> <td>C1-30x16x50</td> <td>30</td> <td>68</td> </tr> </tbody> </table>	Art.-Nr.	Typ	d	D	20.16.021	C1-20x16x50	20	50	25.16.021	C1-25x16x50	25	58	30.16.021	C1-30x16x50	30	68
Art.-Nr.	Typ	d	D														
20.16.021	C1-20x16x50	20	50														
25.16.021	C1-25x16x50	25	58														
30.16.021	C1-30x16x50	30	68														
<p>Axial-Werkzeughalter Form C3 höhenverstellbar Axial toolholder Form C3 adjustable in height</p> 	<table border="1"> <thead> <tr> <th>Art.-Nr.</th> <th>Typ</th> <th>d</th> <th>D</th> </tr> </thead> <tbody> <tr> <td>20.16.031</td> <td>C3-20x16x50</td> <td>20</td> <td>50</td> </tr> <tr> <td>25.16.031</td> <td>C3-25x16x50</td> <td>25</td> <td>58</td> </tr> <tr> <td>30.16.031</td> <td>C3-30x16x50</td> <td>30</td> <td>68</td> </tr> </tbody> </table>	Art.-Nr.	Typ	d	D	20.16.031	C3-20x16x50	20	50	25.16.031	C3-25x16x50	25	58	30.16.031	C3-30x16x50	30	68
Art.-Nr.	Typ	d	D														
20.16.031	C3-20x16x50	20	50														
25.16.031	C3-25x16x50	25	58														
30.16.031	C3-30x16x50	30	68														

Bohrstangenhalter Form E2 höhenverstellbar
Boring bar holder Form E2 adjustable in height

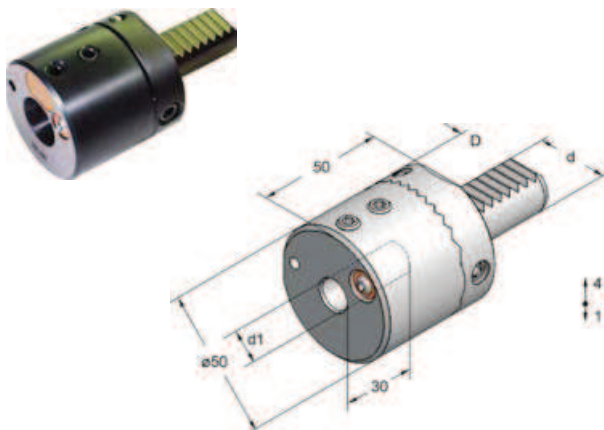

Art.-Nr.	Typ	d	d1	D
20.08.291	E2-20x08x50	20	8	50
20.10.291	E2-20x10x50	20	10	50
20.12.291	E2-20x12x50	20	12	50
20.16.291	E2-20x16x50	20	16	50
20.20.291	E2-20x20x50	20	20	50
25.08.291	E2-25x08x50	25	8	58
25.10.291	E2-25x10x50	25	10	58
25.12.291	E2-25x12x50	25	12	58
25.16.291	E2-25x16x50	25	16	58
25.20.291	E2-25x20x50	25	20	58
30.08.291	E2-30x08x50	30	8	68
30.10.291	E2-30x10x50	30	10	68
30.12.291	E2-30x12x50	30	12	68
30.16.291	E2-30x16x50	30	16	68
30.20.291	E2-30x20x50	30	20	68

Abstechmeisselhalter höhenverstellbar rechts
Toolholder for cut off tools adjustable height right

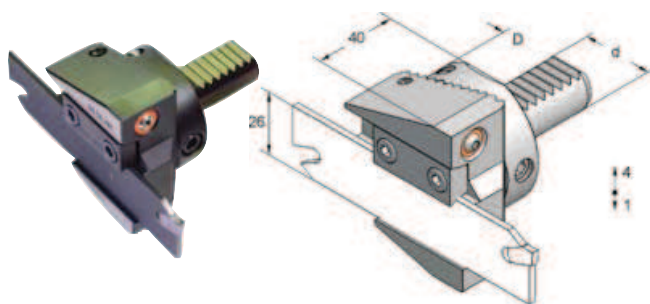

Art.-Nr.	Typ	d	D
20.26.481	20x26x40-r	20	50
25.26.481	25x26x40-r	25	58

Abstechmeisselhalter höhenverstellbar links
Toolholder for cut off tools adjustable height left

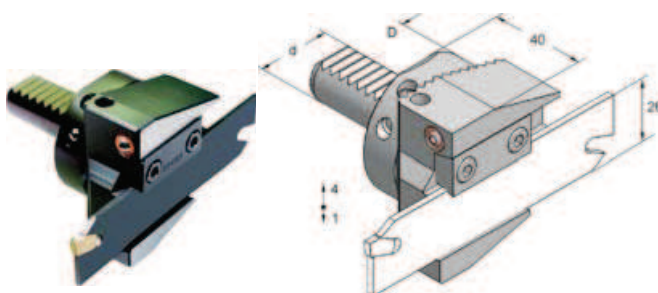

Art.-Nr.	Typ	d	D
20.26.482	20x26x40-l	20	50
25.26.482	25x26x40-l	25	58

Räumwerkzeughalter mit Zylinderschaft
Broaching toolholder with cyl. shank

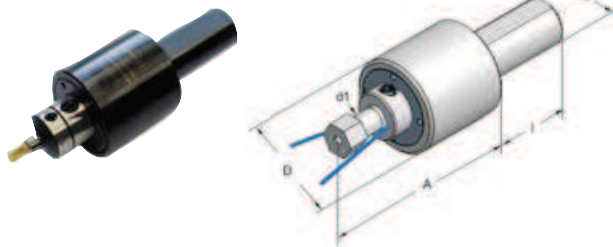

Räumwerkzeughalter DIN 69880
Broaching toolholder DIN 69880

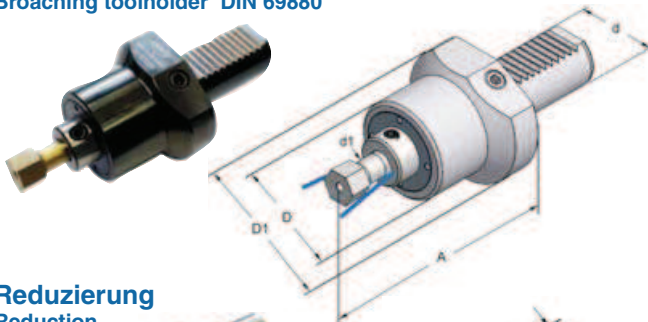

Reduzierung
Reduction



Räumstempel SW
Hexagon-broaching cutter

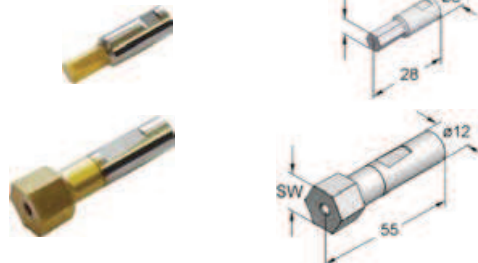

Räumstempel TORX
Broaching cutter TORX



Stangengreifer Spannbereich 10 - 75mm
Bar puller clamping range 10 - 75mm

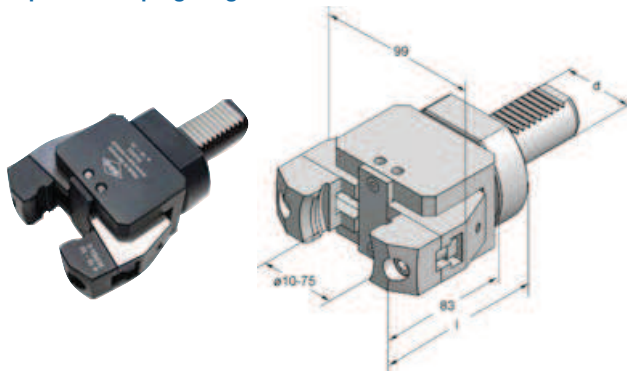

Art.-Nr.	Typ	d	d1	l	D	A
16.08.5010	zyl. 16	16	8	38	40	65
20.08.5010	zyl. 20	20	8	38	40	65
22.08.5010	zyl. 22	22	8	48	40	65
25.08.5010	zyl. 25	25	8	48	40	65
25.12.5010	zyl. 25	25	12	55	50	88
1905.08.5010	zyl. 3/4"	19,05	8	38	40	65
2540.12.5010	zyl. 1"	25,4	12	48	50	88
3175.12.5010	zyl. 1 1/4"	31,75	12	48	50	88

Art.-Nr.	Typ	d	d1	D	D1	A
16.08.5000	VDI 16	16	8	40	44	70
20.08.5000	VDI 20	20	8	40	50	70
25.08.5000	VDI 25	25	8	40	58	70
30.12.5000	VDI 30	30	12	50	68	96
40.12.5000	VDI 40	40	12	50	83	96

Art.-Nr.	Reduzierung
1208.5000	Reduzierung

Art.-Nr.	SW	d	Art.-Nr.	TORX	d
08.020	2	8	08.T06	6	8
08.025	2,5	8	08.T07	7	8
08.030	3	8	08.T08	8	8
08.040	4	8	08.T09	9	8
08.050	5	8	08.T10	10	8
08.060	6	8	08.T15	15	8
08.070	7	8	08.T20	20	8
08.080	8	8	08.T25	25	8
08.100	10	8	08.T27	27	8
12.060	6	12	08.T30	30	8
12.080	8	12	08.T40	40	8
12.100	10	12	08.T45	45	8
12.120	12	12	12.T50	50	8
12.140	14	12	Sonderprofile auf Anfrage Special executions on inquiry		
12.170	17	12			
12.190	19	12			

Art.-Nr.	Art.-Nr. Schaft/Shank	d	l
30.0924			
30.0924-3	VDI 30		103
30.0924-4	VDI 40		103
30.0924-5	VDI 50		103
30.0924-25	zyl.25		83
30.0924-30	zyl.30		83
30.0924-32	zyl.32		83
30.0924-40	zyl.40		83
30.0924-50	zyl.50		83

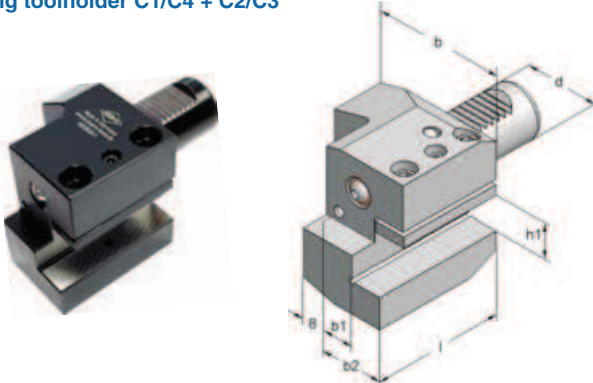
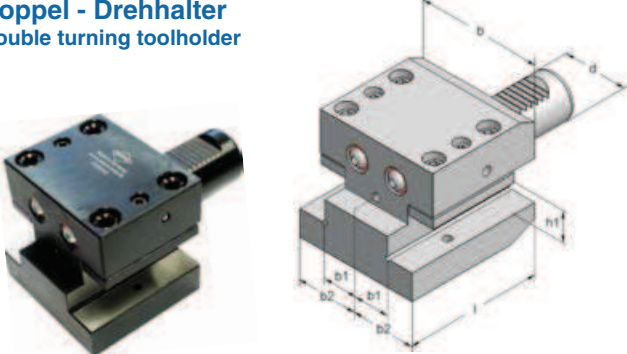
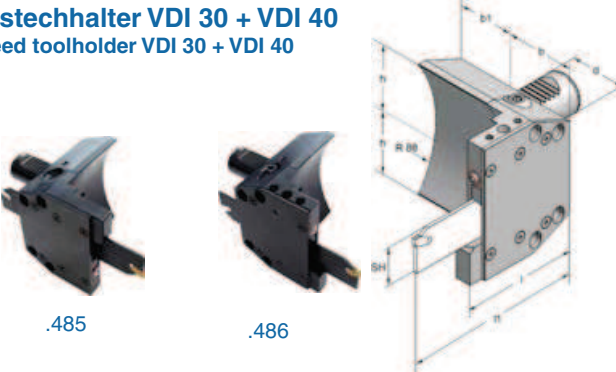
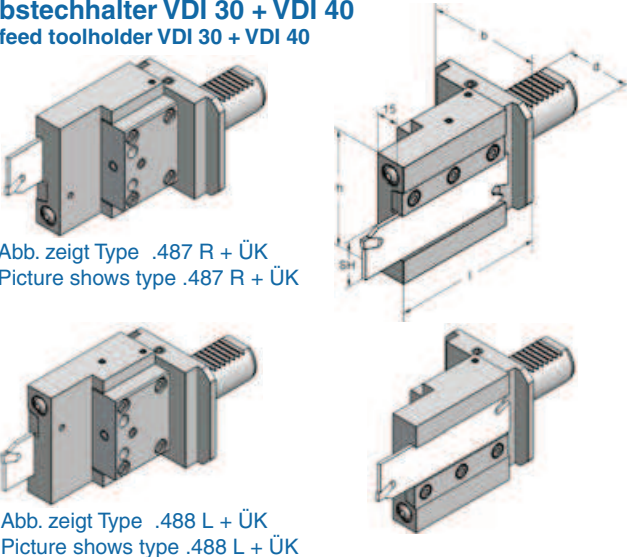
<p>Drehhalter C1/C4 + C2/C3 Turning toolholder C1/C4 + C2/C3</p> 	<table border="1"> <thead> <tr> <th>Art.-Nr.</th> <th>Typ</th> <th>d</th> <th>b</th> <th>b1</th> <th>b2</th> <th>h1</th> <th>l</th> </tr> </thead> <tbody> <tr> <td>30.20.041</td> <td>VDI30 - C1/C4</td> <td>30</td> <td>78</td> <td>26</td> <td>44</td> <td>20</td> <td>90</td> </tr> <tr> <td>30.20.031</td> <td>VDI30 - C2/C3</td> <td>30</td> <td>78</td> <td>26</td> <td>44</td> <td>20</td> <td>90</td> </tr> <tr> <td>40.25.041</td> <td>VDI40 - C1/C4</td> <td>40</td> <td>90</td> <td>25,5</td> <td>47,5</td> <td>25</td> <td>85</td> </tr> <tr> <td>40.25.031</td> <td>VDI40 - C2/C3</td> <td>40</td> <td>90</td> <td>25,5</td> <td>47,5</td> <td>25</td> <td>85</td> </tr> <tr> <td colspan="8" style="text-align: center;">INCH</td> </tr> <tr> <td>310208</td> <td>VDI30 - C1/C4</td> <td>30</td> <td>79</td> <td>23</td> <td>45</td> <td>1"</td> <td>90</td> </tr> <tr> <td>410208</td> <td>VDI40 - C1/C4</td> <td>40</td> <td>90</td> <td>25,5</td> <td>47,5</td> <td>1"</td> <td>85</td> </tr> </tbody> </table> <p>VDI-Schaft mit Doppelverzahnung Abb. zeigt Typ C1/C4 VDI-Shank with double tothing Picture shows type C1/C4</p>	Art.-Nr.	Typ	d	b	b1	b2	h1	l	30.20.041	VDI30 - C1/C4	30	78	26	44	20	90	30.20.031	VDI30 - C2/C3	30	78	26	44	20	90	40.25.041	VDI40 - C1/C4	40	90	25,5	47,5	25	85	40.25.031	VDI40 - C2/C3	40	90	25,5	47,5	25	85	INCH								310208	VDI30 - C1/C4	30	79	23	45	1"	90	410208	VDI40 - C1/C4	40	90	25,5	47,5	1"	85
Art.-Nr.	Typ	d	b	b1	b2	h1	l																																																										
30.20.041	VDI30 - C1/C4	30	78	26	44	20	90																																																										
30.20.031	VDI30 - C2/C3	30	78	26	44	20	90																																																										
40.25.041	VDI40 - C1/C4	40	90	25,5	47,5	25	85																																																										
40.25.031	VDI40 - C2/C3	40	90	25,5	47,5	25	85																																																										
INCH																																																																	
310208	VDI30 - C1/C4	30	79	23	45	1"	90																																																										
410208	VDI40 - C1/C4	40	90	25,5	47,5	1"	85																																																										
<p>Doppel - Drehhalter Double turning toolholder</p> 	<table border="1"> <thead> <tr> <th>Art.-Nr.</th> <th>Typ</th> <th>d</th> <th>b</th> <th>b1</th> <th>b2</th> <th>h1</th> <th>l</th> </tr> </thead> <tbody> <tr> <td>30.20.042</td> <td>VDI30</td> <td>30</td> <td>88</td> <td>26</td> <td>44</td> <td>20</td> <td>90</td> </tr> <tr> <td>40.25.042</td> <td>VDI40</td> <td>40</td> <td>95</td> <td>25,5</td> <td>47,5</td> <td>25</td> <td>85</td> </tr> <tr> <td colspan="8" style="text-align: center;">INCH</td> </tr> <tr> <td>311208</td> <td>VDI30</td> <td>30</td> <td>90</td> <td>23</td> <td>45</td> <td>1"</td> <td>90</td> </tr> <tr> <td>411208</td> <td>VDI40</td> <td>40</td> <td>95</td> <td>25,5</td> <td>47,5</td> <td>1"</td> <td>85</td> </tr> </tbody> </table> <p>VDI-Schaft mit Doppelverzahnung VDI-Shank with double tothing</p>	Art.-Nr.	Typ	d	b	b1	b2	h1	l	30.20.042	VDI30	30	88	26	44	20	90	40.25.042	VDI40	40	95	25,5	47,5	25	85	INCH								311208	VDI30	30	90	23	45	1"	90	411208	VDI40	40	95	25,5	47,5	1"	85																
Art.-Nr.	Typ	d	b	b1	b2	h1	l																																																										
30.20.042	VDI30	30	88	26	44	20	90																																																										
40.25.042	VDI40	40	95	25,5	47,5	25	85																																																										
INCH																																																																	
311208	VDI30	30	90	23	45	1"	90																																																										
411208	VDI40	40	95	25,5	47,5	1"	85																																																										
<p>Abstechhalter VDI 30 + VDI 40 Infeed toolholder VDI 30 + VDI 40</p>  <p>.485 .486</p>	<table border="1"> <thead> <tr> <th>Art.-Nr.</th> <th>Typ</th> <th>d</th> <th>SH</th> <th>b</th> <th>b1</th> <th>h</th> <th>l</th> <th>l1</th> </tr> </thead> <tbody> <tr> <td>30.26.485</td> <td>VDI30x26RL ÜK</td> <td>30</td> <td>26</td> <td>60</td> <td>35</td> <td>50</td> <td>85</td> <td>112</td> </tr> <tr> <td>30.32.485</td> <td>VDI30x32RL ÜK</td> <td>30</td> <td>32</td> <td>60</td> <td>35</td> <td>50</td> <td>85</td> <td>112</td> </tr> <tr> <td>30.26.486</td> <td>VDI30x26RL</td> <td>30</td> <td>26</td> <td>60</td> <td>35</td> <td>50</td> <td>85</td> <td>112</td> </tr> <tr> <td>30.32.486</td> <td>VDI30x32RL</td> <td>30</td> <td>32</td> <td>60</td> <td>35</td> <td>50</td> <td>85</td> <td>112</td> </tr> <tr> <td>40.32.485</td> <td>VDI40x32RL ÜK</td> <td>40</td> <td>32</td> <td>60</td> <td>35</td> <td>50</td> <td>88,5</td> <td>115</td> </tr> <tr> <td>40.32.486</td> <td>VDI40x32RL</td> <td>40</td> <td>32</td> <td>60</td> <td>35</td> <td>50</td> <td>88,5</td> <td>115</td> </tr> </tbody> </table> <p>VDI-Schaft mit Doppelverzahnung Abb. zeigt Type .485 VDI-Shank with double tothing Picture shows type .485</p>	Art.-Nr.	Typ	d	SH	b	b1	h	l	l1	30.26.485	VDI30x26RL ÜK	30	26	60	35	50	85	112	30.32.485	VDI30x32RL ÜK	30	32	60	35	50	85	112	30.26.486	VDI30x26RL	30	26	60	35	50	85	112	30.32.486	VDI30x32RL	30	32	60	35	50	85	112	40.32.485	VDI40x32RL ÜK	40	32	60	35	50	88,5	115	40.32.486	VDI40x32RL	40	32	60	35	50	88,5	115	
Art.-Nr.	Typ	d	SH	b	b1	h	l	l1																																																									
30.26.485	VDI30x26RL ÜK	30	26	60	35	50	85	112																																																									
30.32.485	VDI30x32RL ÜK	30	32	60	35	50	85	112																																																									
30.26.486	VDI30x26RL	30	26	60	35	50	85	112																																																									
30.32.486	VDI30x32RL	30	32	60	35	50	85	112																																																									
40.32.485	VDI40x32RL ÜK	40	32	60	35	50	88,5	115																																																									
40.32.486	VDI40x32RL	40	32	60	35	50	88,5	115																																																									
<p>Abstechhalter VDI 30 + VDI 40 Infeed toolholder VDI 30 + VDI 40</p>  <p>Abb. zeigt Type .487 R + ÜK Picture shows type .487 R + ÜK</p> <p>Abb. zeigt Type .488 L + ÜK Picture shows type .488 L + ÜK</p>	<table border="1"> <thead> <tr> <th>Art.-Nr.</th> <th>Typ</th> <th>d</th> <th>SH</th> <th>b</th> <th>h</th> <th>l</th> </tr> </thead> <tbody> <tr> <td>30.26.487</td> <td>VDI30x26 R+ÜK</td> <td>30</td> <td>26</td> <td>70</td> <td>78</td> <td>95</td> </tr> <tr> <td>30.32.487</td> <td>VDI30x32 R+ÜK</td> <td>30</td> <td>32</td> <td>70</td> <td>78</td> <td>95</td> </tr> <tr> <td>40.32.487</td> <td>VDI40x32 R+ÜK</td> <td>40</td> <td>32</td> <td>70</td> <td>78</td> <td>95</td> </tr> </tbody> </table> <p>Höhenverstellbar ±0,5mm Adjustable in height ±0,5mm</p> <table border="1"> <thead> <tr> <th>Art.-Nr.</th> <th>Typ</th> <th>d</th> <th>SH</th> <th>b</th> <th>h</th> <th>l</th> </tr> </thead> <tbody> <tr> <td>30.26.488</td> <td>VDI30x26 L+ÜK</td> <td>30</td> <td>26</td> <td>70</td> <td>78</td> <td>95</td> </tr> <tr> <td>30.32.488</td> <td>VDI30x32 L+ÜK</td> <td>30</td> <td>32</td> <td>70</td> <td>78</td> <td>95</td> </tr> <tr> <td>40.32.488</td> <td>VDI40x32 L+ÜK</td> <td>40</td> <td>32</td> <td>70</td> <td>78</td> <td>95</td> </tr> </tbody> </table> <p>Höhenverstellbar ±0,5mm Adjustable in height ±0,5mm</p>	Art.-Nr.	Typ	d	SH	b	h	l	30.26.487	VDI30x26 R+ÜK	30	26	70	78	95	30.32.487	VDI30x32 R+ÜK	30	32	70	78	95	40.32.487	VDI40x32 R+ÜK	40	32	70	78	95	Art.-Nr.	Typ	d	SH	b	h	l	30.26.488	VDI30x26 L+ÜK	30	26	70	78	95	30.32.488	VDI30x32 L+ÜK	30	32	70	78	95	40.32.488	VDI40x32 L+ÜK	40	32	70	78	95								
Art.-Nr.	Typ	d	SH	b	h	l																																																											
30.26.487	VDI30x26 R+ÜK	30	26	70	78	95																																																											
30.32.487	VDI30x32 R+ÜK	30	32	70	78	95																																																											
40.32.487	VDI40x32 R+ÜK	40	32	70	78	95																																																											
Art.-Nr.	Typ	d	SH	b	h	l																																																											
30.26.488	VDI30x26 L+ÜK	30	26	70	78	95																																																											
30.32.488	VDI30x32 L+ÜK	30	32	70	78	95																																																											
40.32.488	VDI40x32 L+ÜK	40	32	70	78	95																																																											

Multi-Axial-Drehhalter C1-C4
Multi-axial turning-toolholder C1-C4

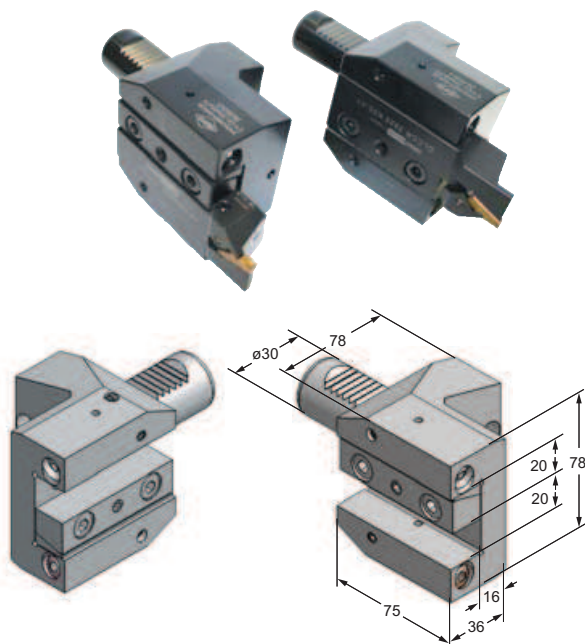

Art.-Nr.	Typ
30.20.043	VDI30 - C1-C4-30x20x75

VDI-Schaft mit Doppelverzahnung
 VDI-Shank with double toothing



Ein Drehhalter - vier Einsatzmöglichkeiten:
links - rechts - vorkopf - überkopf
One turning-toolholder - four possibilities:
left - right - forehead - overhead

Multi-Axial Doppel-Drehhalter C1-C4
Multi-axial double-turning-toolholder C1-C4

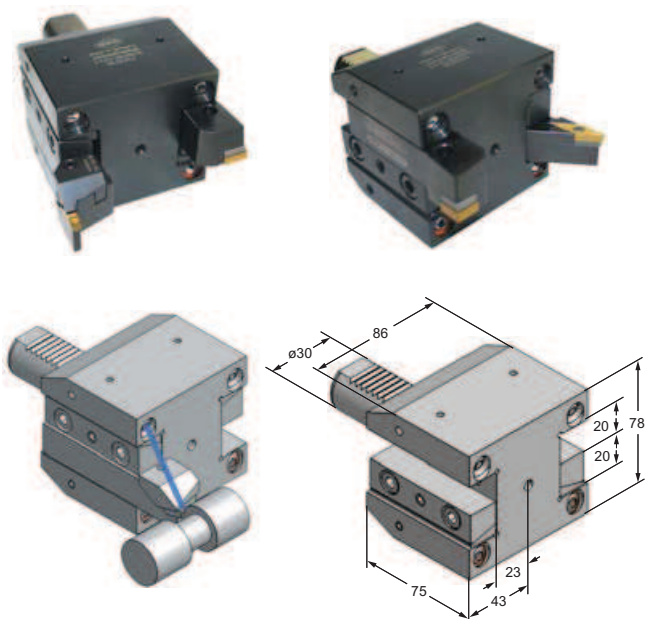

Art.-Nr.	Typ
30.20.044	VDI - C1-C4-30x20x75



Ein Drehhalter - vier Einsatzmöglichkeiten:
links - rechts - vorkopf - überkopf
One turning-toolholder - four possibilities:
left - right - forehead - overhead

VDI 25 Kombiwerkzeughalter

Combi toolholder

Kühlmittelezufuhr intern + extern
 Coolant supply internal + external

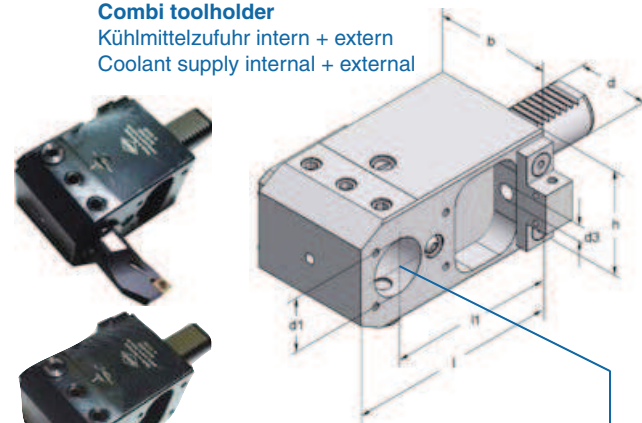

Reduzierbuchse
Reduction bushes



Spannzangenfutter DIN 6499

Collet chuck DIN 6499

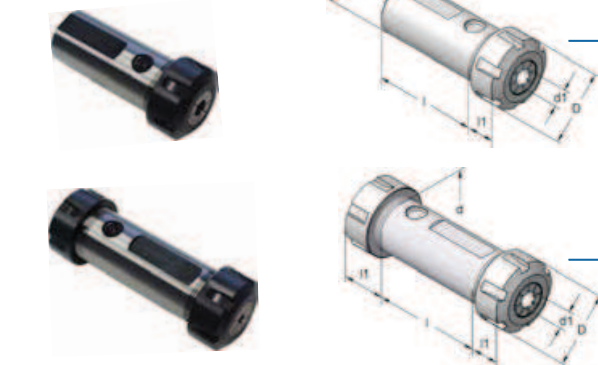

Drehhalter

Turning toolholder

C1-25x20x55

C2-25x20x55

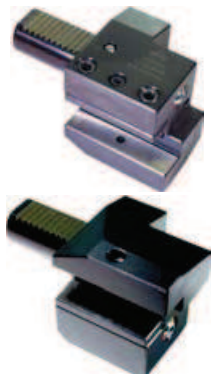

C3-25x20x55

C4-25x20x55

Art.-Nr.	Typ	d	d1	b	h	l	l1	d3
25.25.0075	VDI25x25x75	25	25	60	54	98	75	7
25.32.0075	VDI25x32x75	25	32	60	54	98	75	7

Anschlagplatte links und rechts montierbar
 Stop plate left and right mountable

Art.-Nr.	d	d1	l
25....2950	25	6,8	50
25....295	25	10,12,16,20	50
32....2950	32	6,8,10	60
32....295	32	12,16,20,25	60

Art.-Nr.	Typ	d	d1	D	l	l1
845101	ER 25	25	2-16 430E	42	58	21-25
846101	ER 25	32	2-16 430E	42	58	21-25

Art.-Nr.	Typ	d	d1	D	l	l1
822101	ER 25	32	2-16 430E	42	60	21-25

841101 Verschlussmutter ER25 / Sealing nut ER25

Art.-Nr.	Typ	d	b	b1	b2	h1	l
25.20.020	C1-25x20x55	25	58	15	33	20	55
25.20.050	C2-25x20x55	25	62	19	37	20	55
25.20.030	C3-25x20x55	25	58	15	33	20	55
25.20.040	C4-25x20x55	25	62	19	37	20	55



Abb. zeigt Type 25.20.020 C1-25x20x55
 Picture shows type 25.20.020 C1-25x20x55

VDI 30 Kombiwerkzeughalter

Combi toolholder

Kühlmittelzufuhr intern + extern
 Coolant supply internal + external

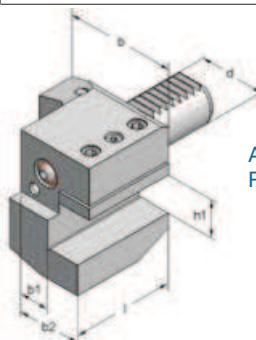
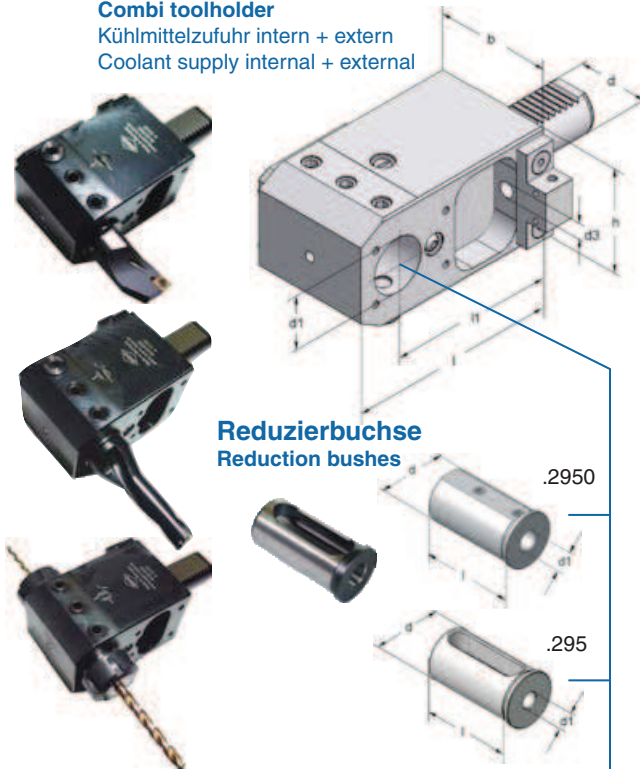

Reduzierbuchse
Reduction bushes

Spannzangenfutter DIN 6499

Collet chuck DIN 6499



Spannzangenfutter DIN 6499/430E mit Aufnahme für Spannung Whistle Notch oder Bohrstanen ø6-16mm

Collet chuck DIN 6499/430E with adaptor for clamping Whistle-Notch and boring bars ø6-16mm

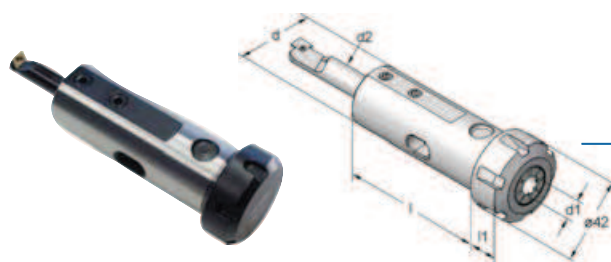

Verschlussmutter 841101
 Sealing nut 841101

Art.-Nr.	Typ	d	d1	b	h	l	l1	d3
30.32.0085	VDI30x32x 85	30	32	70	64	110	85	9
30.32.0100	VDI30x32x100	30	32	70	64	125	100	9
INCH								
312208	VDI30x1¼"x 85	30	1¼"	70	64	110	85	9
313208	VDI30x1½"x100	30	1½"	70	64	125	100	9
HARDINGE								
30.32.0070	VDI30x32x70	30	32	70	64	101	70	
30.40.0070	VDI30x40x70	30	40	70	72	105	70	

Anschlagplatte links und rechts montierbar
 Stop plate left and right mountable

Art.-Nr.	d	d1	l
32....2950	32	6,8,10	60
32....295	32	12,16,20,25	60
INCH			
450101	1¼"	1/4"	59
451101	1¼"	3/8"	59
452101	1¼"	1/2"	59
453101	1¼"	5/8"	59
454101	1¼"	3/4"	59
455101	1¼"	1"	59

Art.-Nr.	Typ	d	d1	D	l	l1
820101	ER 25	32	2-16 430E	42	58	21-25
836101	ER 32	32	2-20 470E	50	58	31-35
INCH						
843101	ER 25	1¼"	2-16 430E	42	58	21-25

Art.-Nr.	Typ	d	d1	D	l	l1
821101	ER 25	32	2-16 430E	42	70	21-25
INCH						
825101	ER 25	1¼"	2-16 430E	42	70	21-25

Art.-Nr.	Typ	d	d1	d2	l	l1
830101	ER 25	32	2-16 430E	6	85	21-25
831101	ER 25	32	2-16 430E	8	85	21-25
832101	ER 25	32	2-16 430E	10	85	21-25
833101	ER 25	32	2-16 430E	12	85	21-25
834101	ER 25	32	2-16 430E	14	85	21-25
835101	ER 25	32	2-16 430E	16	85	21-25
INCH						
850101	ER 25	1¼"	2-16 430E	6	85	21-25
851101	ER 25	1¼"	2-16 430E	8	85	21-25
852101	ER 25	1¼"	2-16 430E	10	85	21-25
853101	ER 25	1¼"	2-16 430E	12	85	21-25
854101	ER 25	1¼"	2-16 430E	14	85	21-25
855101	ER 25	1¼"	2-16 430E	16	85	21-25
841101	Verschlussmutter ER25 / Sealing nut ER25					

VDI 40 Kombiwerkzeughalter

Combi toolholder

Kühlmittelzufuhr intern + extern
 Coolant supply internal + external

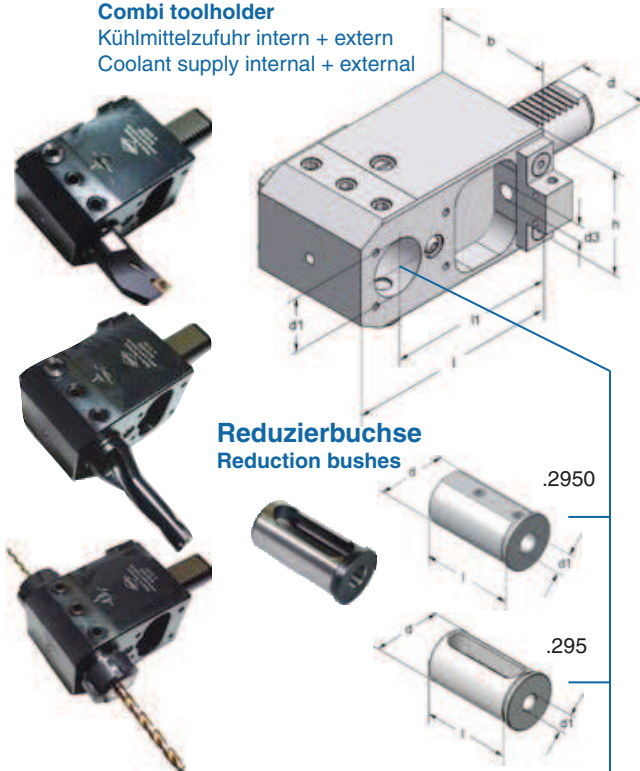

Reduzierbuchse
Reduction bushes

Spannzangenfutter DIN 6499

Collet chuck DIN 6499



Spannzangenfutter DIN 6499/430E mit Aufnahme für Spannung Whistle Notch oder Bohrstanen ø6-16mm

Collet chuck DIN 6499/430E with adaptor for clamping Whistle-Notch and boring bars ø6-16mm

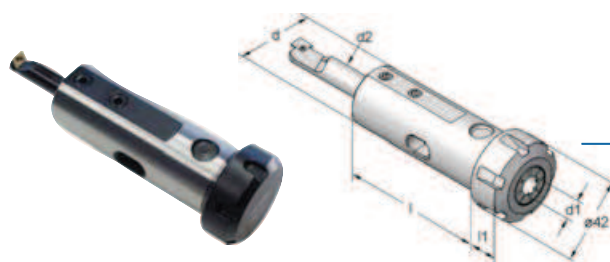

Verschlussmutter 841101
 Sealing nut 841101

Art.-Nr.	Typ	d	d1	b	h	l	l1	d3
40.25.0100	VDI40x25x100	40	25	85	76	122	100	11
40.32.0100	VDI40x32x100	40	32	85	76	125	100	11
40.40.0100	VDI40x40x100	40	40	85	76	129	100	11
40.25.0120	VDI40x25x120	40	25	85	76	142	120	11
40.32.0120	VDI40x32x120	40	32	85	76	145	120	11
40.40.0120	VDI40x40x120	40	40	85	76	149	120	11

INCH

412208	VDI40x1¼"x100	40	1¼"	85	76	125	100	11
413208	VDI40x1½"x100	40	1½"	85	76	129	100	11
414208	VDI40x1¼"x120	40	1¼"	85	76	145	120	11
415208	VDI40x1½"x120	40	1½"	85	76	149	120	11

Anschlagplatte links und rechts montierbar

Stop plate left and right mountable

Art.-Nr.	d	d1	l
32....2950	32	6,8,10	60
32....295	32	12,16,20,25	60
40....2950	40	6,8,10,12	72
40....295	40	16,20,25,32	72

INCH

450101	1¼"	1/4"	60
451101	1¼"	3/8"	60
452101	1¼"	1/2"	60
453101	1¼"	5/8"	60
454101	1¼"	3/4"	60
455101	1¼"	1"	60

Art.-Nr.	Typ	d	d1	D	l	l1
820101	ER 25	32	2-16 430E	42	58	21-25
836101	ER 32	32	2-20 470E	50	58	31-35
117102	ER 32	40	2-20 470E	50	64	24-29

INCH

843101	ER 25	1¼"	2-16 430E	42	58	21-25
827101	ER 32	1½"	2-20 470E	50	64	24-29

Art.-Nr.	Typ	d	d1	D	l	l1
823101	ER 25	32	2-16 430E	42	85	21-25
824101	ER 32	40	2-20 470E	50	85	24-29
826101	ER 25	1¼"	2-16 430E	42	85	21-25

Art.-Nr.	Typ	d	d1	d2	l	l1
830101	ER 25	32	2-16 430E	6	85	21-25
831101	ER 25	32	2-16 430E	8	85	21-25
832101	ER 25	32	2-16 430E	10	85	21-25
833101	ER 25	32	2-16 430E	12	85	21-25
834101	ER 25	32	2-16 430E	14	85	21-25
835101	ER 25	32	2-16 430E	16	85	21-25

INCH

850101	ER 25	1¼"	2-16 430E	6	85	21-25
851101	ER 25	1¼"	2-16 430E	8	85	21-25
852101	ER 25	1¼"	2-16 430E	10	85	21-25
853101	ER 25	1¼"	2-16 430E	12	85	21-25
854101	ER 25	1¼"	2-16 430E	14	85	21-25
855101	ER 25	1¼"	2-16 430E	16	85	21-25

841101	Verschlussmutter ER25 / Sealing nut ER25						
842101	Verschlussmutter ER32 / Sealing nut ER32						

VDI 30 Kombiwerkzeughalter

VDI 40 Combi toolholder
 Kühlmittelzufuhr intern + extern
 Coolant supply internal + external

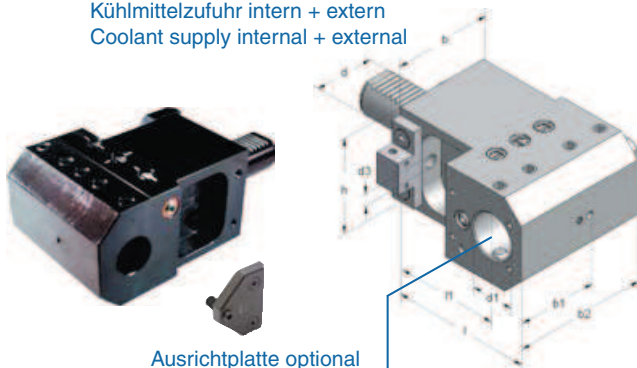

Ausrichtplatte optional
 Adjust plate optional

Reduzierbuchse
 Reduction bushes

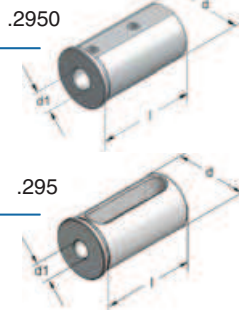

Art.-Nr.	Typ	d	d1	b	b1	b2	h	l	l1	d3	
30.32.0853	VDI30x32x	85	30	32	70	57,5	98	68	110	85	9
30.32.0103	VDI30x32x100	30	32	70	57,5	98	68	125	100	9	
30.32.0123	VDI30x32x120	30	32	70	57,5	98	68	145	120	9	

40.32.0103	VDI40x32x100	40	32	85	77,5	120	76	129	100	11
40.32.0123	VDI40x32x120	40	32	85	77,5	120	76	149	120	11

Anschlagplatte links und rechts montierbar
 Stop plate left and right mountable

Ausrichtplatte für Kombiwerkzeughalter VDI 25, 30, 40
 Adjust plate for combi toolholder VDI 25, 30, 40

Art.-Nr.	Typ
579101	VDI25x....
576101	VDI30x....
523101	VDI40x....

Art.-Nr.	d	d1	l
32....2950	32	6,8,10	60
32....295	32	12,16,20,25	60

VDI 30 Kombiwerkzeughalter zurückgestzt

VDI 40 Combi toolholder set back
 Kühlmittelzufuhr intern + extern
 Coolant supply internal + external

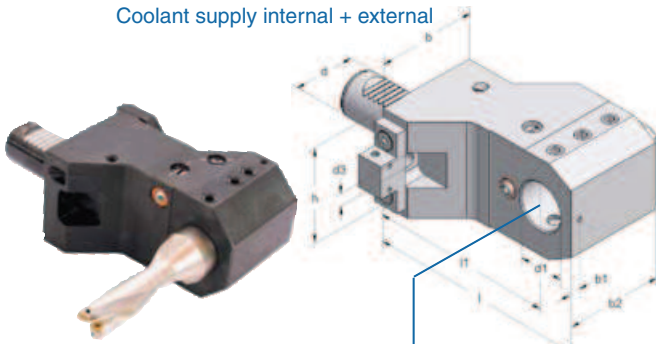

Distanzbuchse
 Reduction bushes

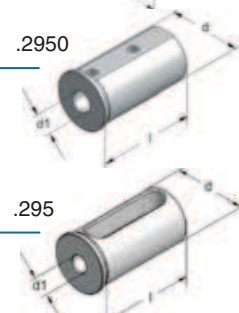

Spannzangenfutter DIN 6499
 Collet chuck DIN 6499



Art.-Nr.	Typ	d	d1	b	b1	b2	h	l	l1	d3	
30.32.00085	VDI30x32x	85	30	32	70	7	69	68	110	85	9
30.30.00100	VDI30x30x100	30	30	70	7	69	68	125	100	9	
30.32.00100	VDI30x32x100	30	32	70	7	69	68	125	100	9	
30.40.00100	VDI30x40x100	30	40	70	7	69	68	129	100	9	

40.40.00100	VDI40x40x100	40	40	85	7	75	76	129	100	11
40.40.00120	VDI40x40x120	40	40	85	7	75	76	149	120	11

Anschlagplatte links und rechts montierbar
 Stop plate left and right mountable
 VDI-Schaft mit Doppelverzahnung
 VDI-Shank with double toothing

Art.-Nr.	d	d1	l
32....2950	32	6,8,10	60
32....295	32	12,16,20,25	60
40....2950	40	6,8,10,12	72
40....295	40	16,20,25,32	72

Art.-Nr.	Typ	d	d1	D	l	l1	
820101	ER 25	32	2-16	430E	42	58	21-25
836101	ER 32	32	2-20	470E	50	58	31-35
117102	ER 32	40	2-20	470E	50	64	24-29

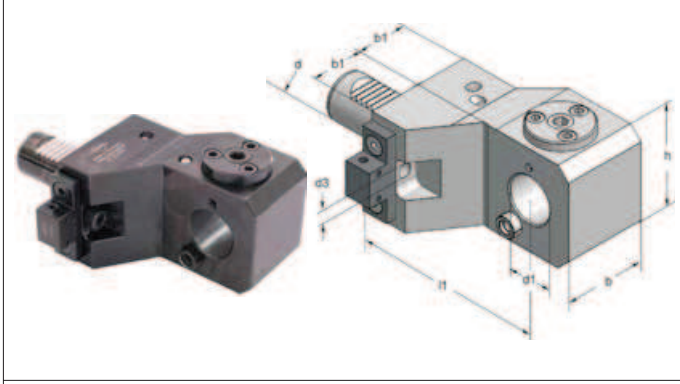
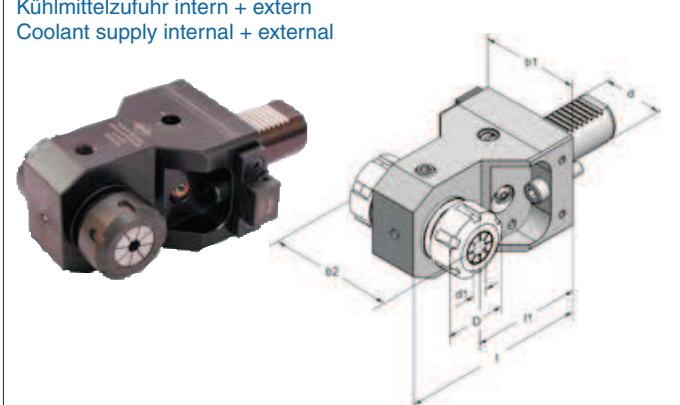
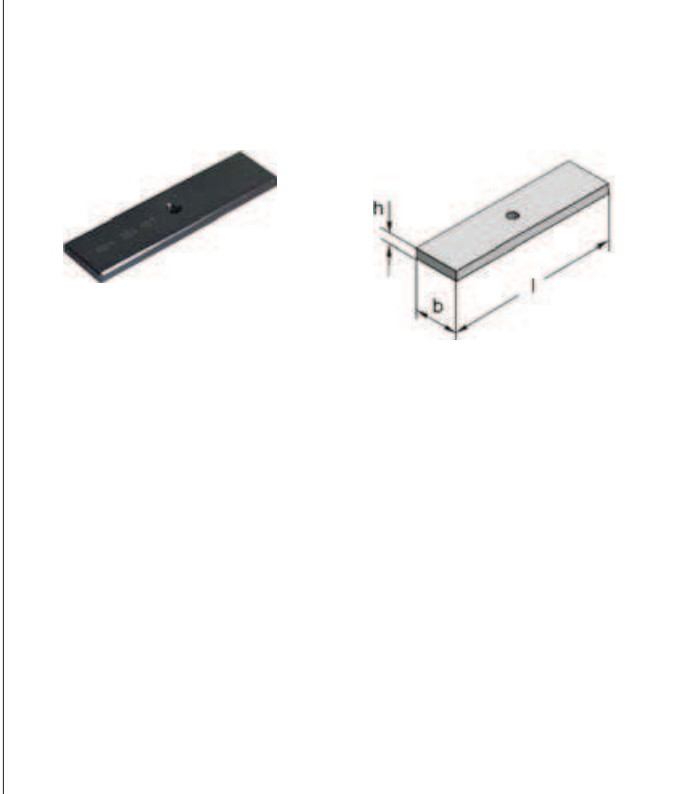
Ausgleichhalter VDI 30 + VDI 40 Adaptor for VDI 30 + VDI 40	Art.-Nr. Typ d d1 b b1 h l1 d3
	30.30.085 VDI30x30x 85 30 30 55 35 68 85 9
	30.30.100 VDI30x30x100 30 30 55 35 68 100 9
	40.40.100 VDI40x40x100 40 40 63 42,5 85 100 11
	40.40.120 VDI40x40x120 40 40 63 42,5 85 120 11
	VDI-Schaft mit Doppelverzahnung VDI-Shank with double toothing Anschlagplatte links und rechts montierbar Stop plate left and right mountable
Doppel-Spannzangenhalter VDI 30 + VDI 40 Double-collet chuck toolholder VDI 30 + VDI 40 Kühlmittelzufuhr intern + extern Coolant supply internal + external	Art.-Nr. Typ d d1 D b1 b2 l1 l
	30.085.16 VDI30xER25x 85 30 1-16 42 70 88 85 110
	40.100.20 VDI40xER32x100 40 2-20 50 85 104 100 129
	841101 Verschlussmutter ER25 / Sealing nut
	842101 Verschlussmutter ER32 / Sealing nut
	Anschlagplatte links und rechts montierbar Stop plate left and right mountable
Unterlegplatte Shim	Art.-Nr. für Typ l bxh
	314101 20.16.020 20.16.030 20.16.040 20.16.050 54 14x4
	315101 20.16.060 20.16.070 20.16.080 20.16.090 49 14x4
	303101 20.16.100 20.16.110 20.16.120 20.16.130 74 14x4
	324101 20.16.150 20.16.160 65 14x4
	304101 30.20.020 .030 .040 .050 .060 .070 69 18x4
	30.20.080 .090 .150 .160 .170 .180
	309101 30.20.100 30.20.110 30.20.120 30.20.130 97 18x4
	310101 40.25.020 40.25.030 40.25.040 40.25.050 84 22x5
	40.25.060 40.25.070 40.25.080 40.25.090
	311101 40.25.100 40.25.110 40.25.120 40.25.130 107 22x5
	326101 40.25.150 40.25.160 40.25.170 40.25.180 83 22x5
	306101 50.32.020 50.32.030 50.32.150 50.32.170 99 24x7
	301101 50.32.040 50.32.050 50.32.060 50.32.070 98 25x7
	50.32.080 50.32.090
	305101 50.32.100 50.32.110 50.32.120 50.32.130 128 25x7
	331101 50.32.150 50.32.170 120 24x7
	327101 50.32.160 50.32.180 105 25x7
	312101 60.32.020 .030 .040 .050 .060 .070 124 30x7
	60.32.080 .090 .150 .160 .170 .180
	313101 60.32.100 60.32.110 60.32.120 60.32.130 144 30x7

Dehnspannfutter DIN 69880

Expansion chuck DIN 69880



Dehnspannfutter

Expansion chuck

Kühlmitteldruck bis 120 bar intern + extern
Coolant nozzles up to 120 bar internal + external

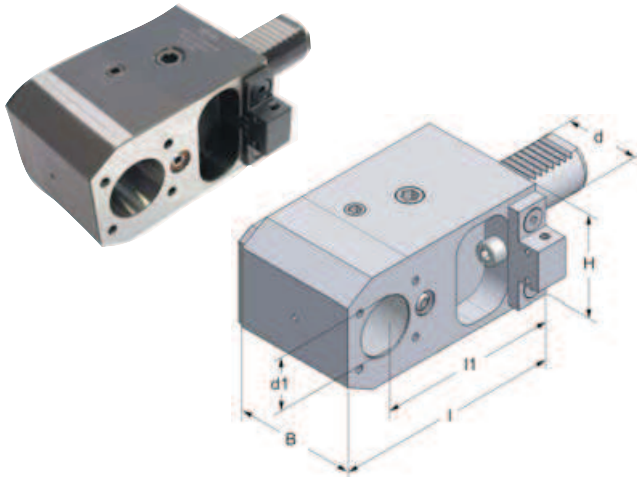

**Werkzeugschäfte mit Spannfläche
nur mit Zwischenhülse spannen!**
Tool shanks with clamping surface can only
be clamped with an intermediate sleeve!

Art.-Nr.	d	d1	B	H	I	I1
25.25.4060	25	25	60	56	83	60
25.25.4070	25	25	60	56	93	70
30.32.4085	30	32	70	64	110	85
30.32.4100	30	32	70	64	125	100

Dehnspannfutter Form E2

Expansion chuck form E2

Kühlmitteldruck bis 120 bar intern + extern
Coolant nozzles up to 120 bar internal + external

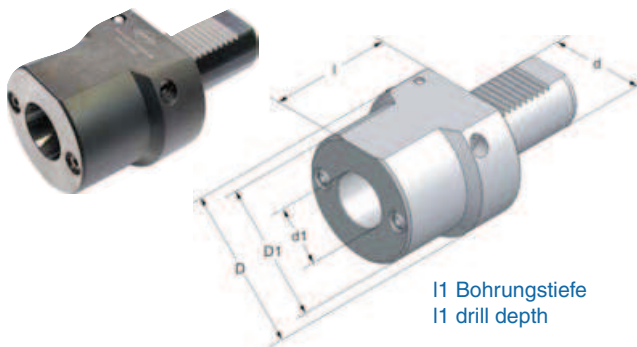

**Werkzeugschäfte mit Spannfläche
nur mit Zwischenhülse spannen!**
Tool shanks with clamping surface can only
be clamped with an intermediate sleeve!

Art.-Nr.	d	d1	D	D1	I	I1
25.20.400	25	20	60	58	60	55 / ø6-12x 95
30.20.400	30	20	68	58	60	55 / ø6-16x100
40.32.400	40	32	83	72	75	67 / ø6-20x120

Zwischenhülse

Sleeves



Art.-Nr.	ø
203200	20 x 06
203201	20 x 08
203202	20 x 10
203203	20 x 12
203205	20 x 16

Art.-Nr.	ø
250060	25 x 06
250080	25 x 08
250100	25 x 10
250120	25 x 12
250160	25 x 16
250200	25 x 20
204320	32 x 06
204321	32 x 08
204322	32 x 10
204323	32 x 12
204325	32 x 16
204327	32 x 20
204328	32 x 25



Axial Bohr- und Fräskopf
Axial drilling and milling head

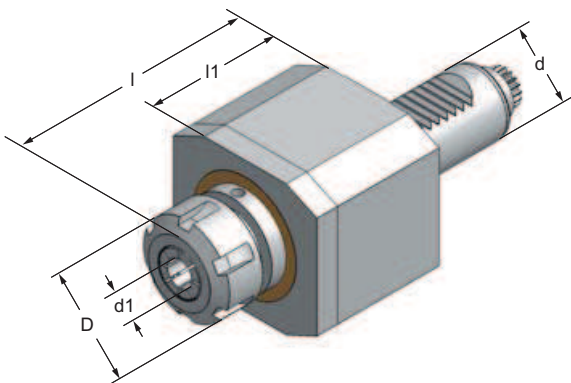

Art.-Nr.	Typ	d	d1	D	l	l1
4.2016	VDI20xER16	20	1-10 426E	28	76	49
4.2525	VDI25xER25	25	1-16 430E	42	86	58
4.3025	VDI30xER25	30	1-16 430E	42	88	58
4.4032	VDI40xER32	40	2-20 470E	50	110	76
4.5040	VDI50xER40	50	3-30 472E	63	120	80

Sauter-Revolver DIN 5480 CTX
 Sauter-Revolver DIN 5482 5482
 Diplomatic DIN 1809 1809
 Barrufaldi TOEM TOEM

Beispiel / Example: 4.3025 CTX

Bitte geben Sie bei Ihrer Anfrage den Maschinentyp an
 In case of inquiry please indicate details of type of machine as shown

Schwenkkopf
Swivel head

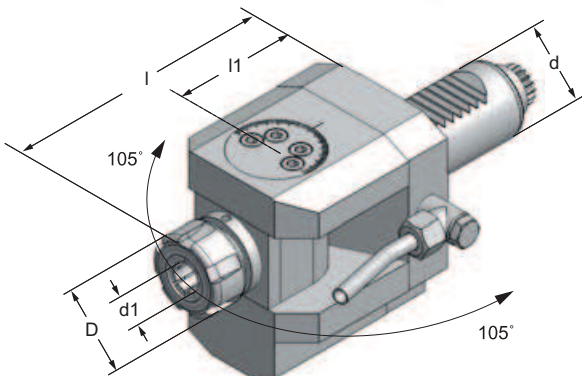

Art.-Nr.	Typ	d	d1	D	l	l1
5.2016	VDI20xER16	20	1-10 426E	28	118	64
5.2516	VDI25xER16	25	1-10 426E	28	102	53
5.3020	VDI30xER20	30	1-13 428E	35	115	60
5.4025	VDI40xER25	40	1-16 430E	42	120	57
5.5040	VDI50xER32	50	2-20 470E	50		

Sauter-Revolver DIN 5480 CTX
 Sauter-Revolver DIN 5482 5482
 Diplomatic DIN 1809 1809
 Barrufaldi TOEM TOEM

Beispiel / Example: 5.4025 CTX

Bitte geben Sie bei Ihrer Anfrage den Maschinentyp an
 In case of inquiry please indicate details of type of machine as shown

Radial Bohr- und Fräskopf
Radial drilling and milling head

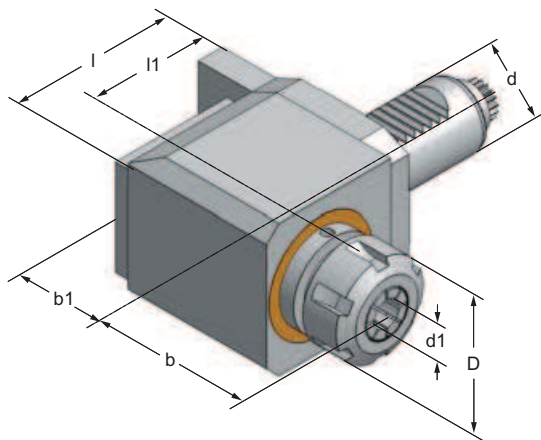

Art.-Nr.	Typ	d	d1	D	l	l1	b	b1
6.2016	VDI20xER16	20	1-10 426E	28	68	45	57	78
6.2525	VDI25xER25	25	1-16 430E	42				
6.3025	VDI30xER25	30	1-16 430E	42	81	55	66	48
6.4032	VDI40xER32	40	2-20 470E	50	103	65	82	72
6.5040	VDI50xER40	50	3-30 472E	63	119	75	96	84

Sauter-Revolver DIN 5480 CTX
 Sauter-Revolver DIN 5482 5482
 Diplomatic DIN 1809 1809
 Barrufaldi TOEM TOEM

Beispiel / Example: 6.4025 CTX

Ausführung R wie gezeichnet / Right hand design as shown
 Ausführung L spiegelbildlich / Left hand design reversed

Bitte geben Sie bei Ihrer Anfrage den Maschinentyp an
 In case of inquiry please indicate details of type of machine as shown

Radial Bohr- und Fräskopf achsversetzt
Radial drilling and milling head offset

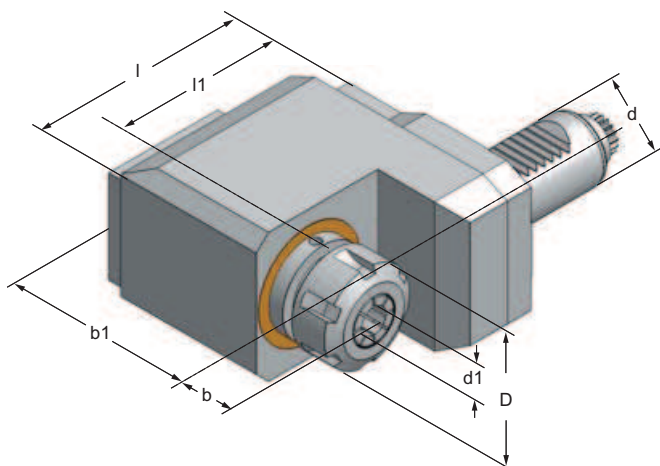

Art.-Nr.	Typ	d	d1	D	l	l1	b	b1
8.2016	VDI20xER16	20	1-10 426E	28	77	54	22	81
8.3025	VDI30xER25	30	1-16 430E	42	96	70	22	83
8.4032	VDI40xER32	40	2-20 470E	50	128	90	32	100
8.5040	VDI50xER40	50	3-30 472E	63	156	112	30	126

Sauter-Revolver DIN 5480 CTX
 Sauter-Revolver DIN 5482 5482
 Diplomatic DIN 1809 1809
 Barrufaldi TOEM TOEM

Beispiel / Example: 8.4025 CTX

Ausführung R wie gezeichnet / Right hand design as shown
 Ausführung L spiegelbildlich / Left hand design reversed

Bitte geben Sie bei Ihrer Anfrage den Maschinentyp an
 In case of inquiry please indicate details of type of machine as shown

Reduzierbuchse für Bohrstangenhalter Reduction bushes for boring bar holders		Art.-Nr.	für Typ	d	d1	l
	25....2950	30.25.290	25	6,8	50	
	25....295	30.25.290	25	10,12,16,20	50	
	32....2950	40.32.290	32	6,8,10	60	
	32....295	40.32.290	32	12,16,20,25	60	
	40....2950	50.40.290	40	6,8,10,12	72	
	40....295	50.40.290	40	16,20,25,32	72	
	50....2950	60.50.290	50	10,12,16	85	
	50....295	60.50.290	50	20,25,32,40	85	

Hakenschlüssel für Ortlieb-Spannmuttern DIN 6388 Hook spanner for Ortlieb-nuts DIN 6388		Art.-Nr.	Typ	d
	54635	40 - 42	40 - 42	
	54643	45 - 50	45 - 50	
	54668	58 - 65	58 - 65	
	54676	68 - 75	68 - 75	

Hakenschlüssel für Spannmuttern DIN 6499 Hook spanner for nuts DIN 6499		Art.-Nr.	Typ	d
	911180	GS 17	SW17	
	916180	GS 25	SW25	
	920180	GS 30	SW30	
	916181	E 16	32	
	920181	E 20	34	
	925180	E 25	42	
	932180	E 32	50	
	940180	E 40	63	
	950180	E 50	78	

Spritzdüsen-Element Coolant nozzle										Gewindestift Threaded pin	Düse Nozzle
Art.-Nr.	d	d1	d2	M	l	D	L	α°	Art.-Nr.	Art.-Nr.	
1005	6	4,0	4	2,5	4,5	6	5,0	30			
1007	8	5,5	7	3,5	6,0	8	6,5	30	1021 M3,5x4		
1008	10	5,5	8	4	7,0	10	8,0	30	1024 M4 x4		
1010	12	7,5	10	5	8,0	12	9,0	30	1025 M5 x5	1035 M5x5	
1010-4	12	7,5	10	6	8,0	12	9,0	30	1026 M6 x6	1036 M6x6	
1012	14	9,0	12	6	10,0	14	11,0	40	1026 M6 x6	1036 M6x6	
1012-4	14	9,0	12	6x0,75	10,0	14	11,0	40			
1012-5	14	9,0	12	7	10,0	14	11,0	30	1027 M7 x7	1037 M7x7	
1014	16	10,0	14	7	11,0	16	12,0	40	1027 M7 x7	1037 M7x7	

Spritzkugel Injection ball		Art.-Nr.	d	M
	08.920	8	4	
	10.920	10	5	
	10.920-4	10	6	
	12.920	12	6	
	14.920	14	7	

Spritzrohr Cu Injection tube Cu		Art.-Nr.	(für Typ Nr.)	G	D	d	L	L1
	10086	(1008)	M4	4	2,5	30	5	
	10106	(1010)	M5	5	3,0	35	6	
	10126	(1012/1010-4)	M6	6	4,0	40	6	
	10146	(1014/1012-5)	M7	7	4,5	50	6	

VDI Werkzeughalter
VDI toolholders

VDI 30 Werkzeughalter mit Aufnahme AWN 28
VDI 30 Toolholder with AWN 28



VDI 40 Pendelhalter zurückgesetzt ER 25
VDI 40 Floating toolholder ER 25



VDI 30 Kombiwerkzeughalter für MORI-SEIKI
VDI 30 Universal toolholder for MORI-SEIKI



VDI 40 Bohrstangenhalter für HITACHI-SEIKI
VDI 40 Boring bar holder for HITACHI-SEIKI

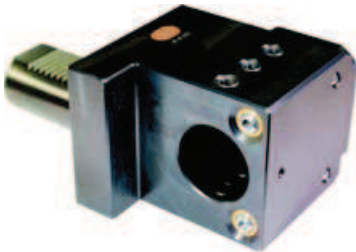

VDI 30 Ausgleichhalter für Gildemeister MF-Sprint
VDI 30 Adapter for Gildemeister MF-Sprint



Abstechhalter System ARNO
Infeed toolholder System ARNO



Werkzeughalter für NAKAMURA - Drehzentren
Toolholders for NAKAMURA - turningcenters



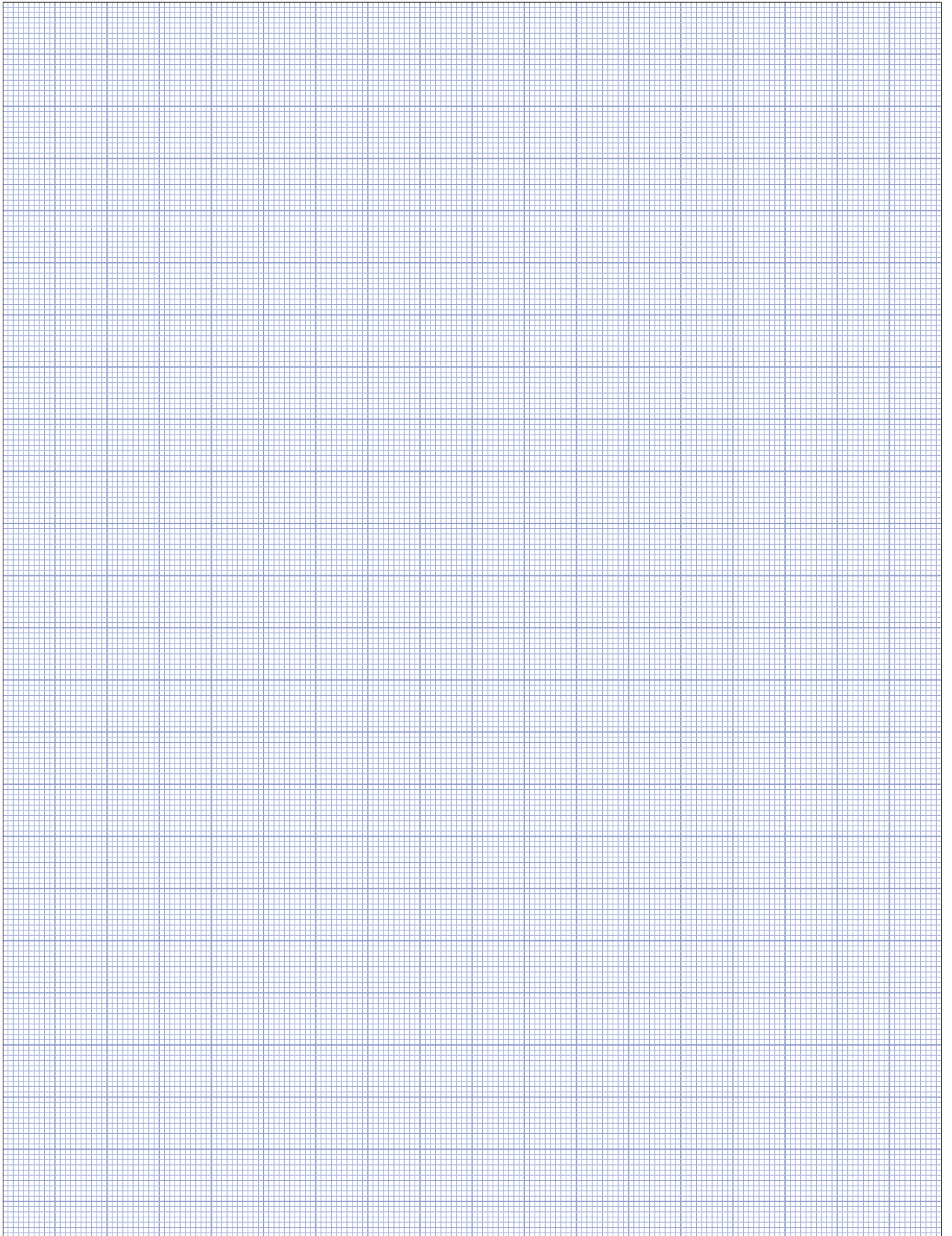

Steilkegel-Werkzeugaufnahmen DIN 2080 DIN 69871 MAS BT

ISO Taper-Toolholders
DIN 2080 DIN 69871 MAS BT



Wuchtanforderungen an Werkzeugaufnahmen für Hochgeschwindigkeitsbearbeitung

Demand of balanced toolholders for high speed machining

Werkzeugmaschinen und Schneidwerkzeuge der neuen Generation garantieren höchste Präzision bei stetig steigenden Schnittdaten (HSC-Bearbeitung). Um diesen Anforderungen gerecht zu werden fertigen wir unsere Standardwerkzeugaufnahmen bereits in vorgewuchteter Qualität, so daß Sie in den meisten Fällen der Anwendung sofort eingesetzt werden können. Bei Drehzahlen von 10.000 U/min bis 25.000 U/min kann ein zusätzliches Feinwuchten in einer oder zwei Ebenen erforderlich sein. Dies gilt besonders bei den Schnittstellen nach DIN 69871 und DIN 69893-A. Bei höheren Drehzahlen sollten die Werkzeugaufnahmen komplett mit Schneidwerkzeug feinstgewuchtet werden. Unser Auswucht-Service freut sich Sie auch hier beraten zu können, damit Ihre Werkzeuge den Anforderungen der DIN ISO 1940 entsprechend statisch oder dynamisch gewuchtet werden können.

Wir empfehlen die Wuchtgüte G 6,3.

Bitte fragen Sie uns. Wir bedienen Sie gerne.

Telefon-Hotline (0 70 72) 92 98 12

The new generation of machine tools and cutting tools guarantee the highest precision for continuous increasing cutting values (HSC). In order to be in pace with this development we produce our standard toolholders in pre-balanced condition, as such they could be adapted in most cases for immediate use. For rotations from 10.000 to 25.000 rpm an additional precise balancing on one or two planes can be necessary. This is particularly for tools with shank according to DIN 69871 and DIN 69893-A. In case of even higher speed, precise balancing has to be done on the toolholder with the tools clamped on. Our balancing-service would be delighted to advise you, so that your tools correspond to the demand of DIN 1940 in statically or dynamically balanced condition.

We recommend a balanced quality G 6,3.

Call our Hotline: (0 70 72) 92 98 12

Gewuchtete Werkzeugaufnahmen . . .

Balanced toolholders . . .

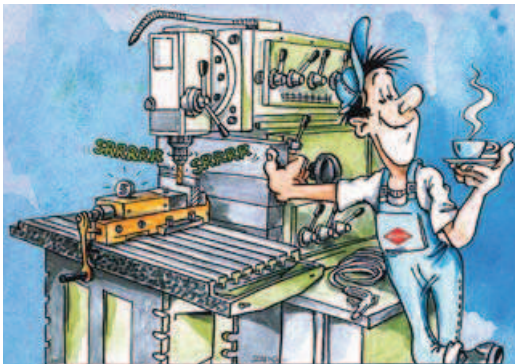

... erhöhen die Lebensdauer der Spindellager und garantieren beste Oberflächengüte bei höchster Standzeit der Werkzeuge!

... increase life span of spindle-bearing, guaranteed superb surface finishing and optimum toollife for your cutting tools!

Art.-Nr.	Wuchtgüte
2520	G 2,5 - 20.000 U/min
2525	G 2,5 - 25.000 U/min
2530	G 2,5 - 30.000 U/min
2540	G 2,5 - 40.000 U/min
6320	G 6,3 - 20.000 U/min
6330	G 6,3 - 30.000 U/min
6340	G 6,3 - 40.000 U/min

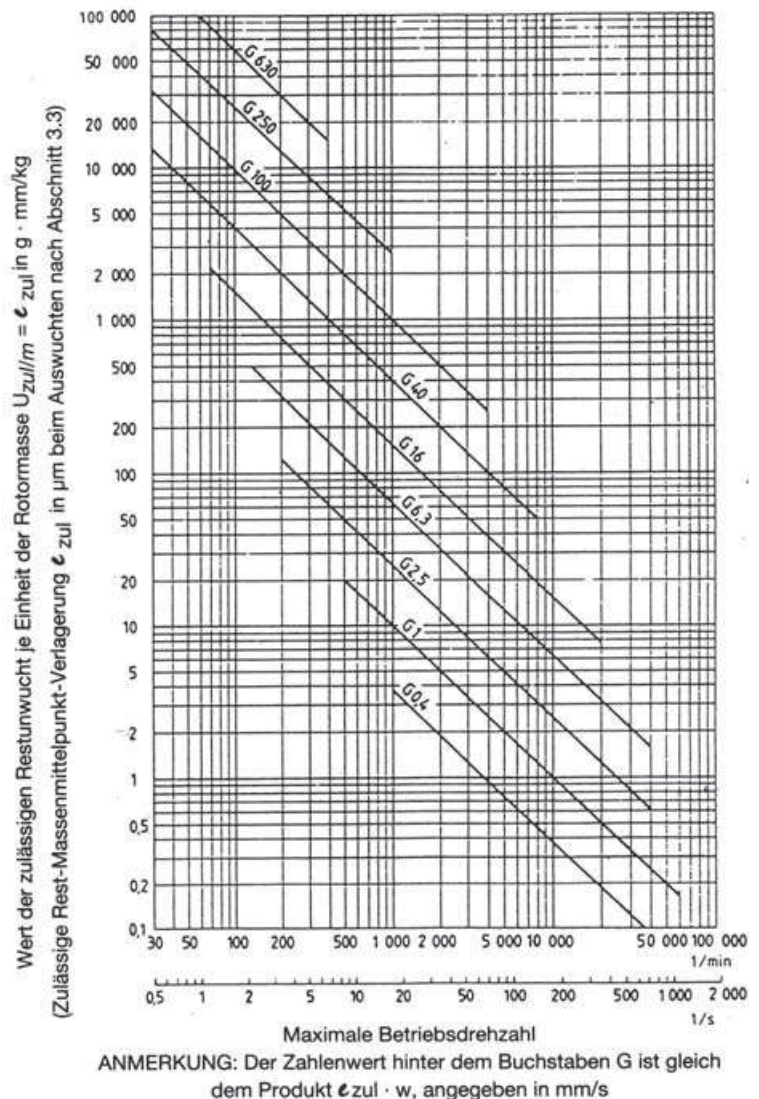

Kegelwinkel AT3, Rundlaufgenauigkeit Steilkegel zu Werkzeugaufnahme < 0,005 Taper angle AT3, Concentricity from the taper to the holding part < 0,005

DIN 2080 40.00. ...

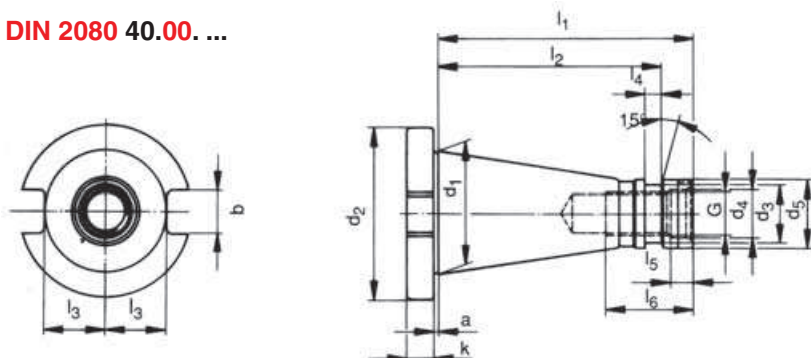

SK	d1	d2	d3	d4	d5	G	a	b	I1	I2	I3	I4	I5	I6	k
30	31,75	50,0	16,5	13	17,10	M 12	1,6	16,1	68,4	51,4	16,2	3	5,5	24	8
40	44,45	63,0	21,1	17	25,00	M 16	1,6	16,1	93,4	82,0	22,5	7	8,2	32	10
50	69,85	97,5	32,0	26	39,29	M 24	3,2	25,7	126,8	115,0	35,3	13	11,0	47	12

DIN 69871 40.01. ...

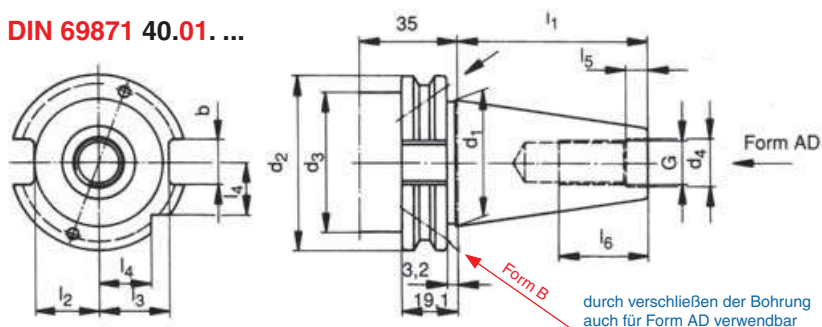

SK	d1	d2	d3	d4	G	b	I1	I2	I3	I4	I5	I6
30	31,75	50,00	45	13	M 12	16,1	67,80	16,4	19,0	15,0	5,5	24
40	44,45	63,55	50	17	M 16	16,1	68,40	22,8	25,0	18,5	8,2	32
45	57,15	82,55	63	21	M 20	19,3	82,70	29,1	31,3	24,0	10,0	40
50	69,85	97,50	80	25	M 24	25,7	101,75	35,5	37,7	30,0	11,5	47

JIS B 6339 BT 40.05. ...

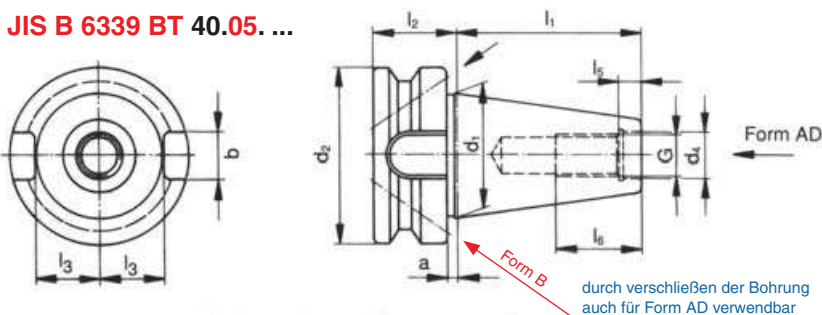

SK	d1	d2	d4	G	a	b	I1	I2	I3	I5	I6
30	31,75	46	12,5	M 12	2	16,1	48,4	22	16,3	7,0	24
35	38,10	53	13,0	M 12	2	14,0	56,5	22	19,3	7,0	27
40	44,45	63	17,0	M 16	2	16,1	65,4	27	22,6	8,2	30
45	57,15	85	21,0	M 20	3	19,3	82,8	33	29,0	9,0	40
50	69,85	100	25,0	M 24	3	25,7	101,8	38	35,3	11,0	45

Spannzangenfutter für Spannzangen DIN 6499 (ER/ESX)

Collet chuck for collets DIN 6499 (ER/ESX)

Kegelwinkel AT3, Rundlaufgenauigkeit Steilkegel zu Werkzeugaufnahme < 0,005
Taper angle AT3, Concentricity from the taper to the holding part < 0,005

gewuchtet G 6,3 - 20.000 U/min. DIN 69871 SK 30 + 40, MAS BT 30 + 40
balanced G 6,3 - 20.000 r.p.m. DIN 69871 SK 30 + 40, MAS BT 30 + 40

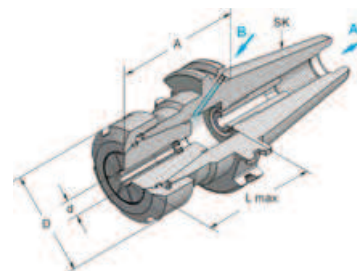

DIN 2080



DIN 69871



MAS BT

Art.-Nr.	SK	A	d	D	L	Art.-Nr.	SK	A	d	D	L	Art.-Nr.	SK	A	d	D	L
												15.05.07.2	15	50	1- 7	19	36
												15.05.10.2	15	40	1-10	28	36
						30.01.07.2	30-AD	70	1-7	18	42	30.05.07.2	30-AD	70	1- 7	19	42
						30.01.10.2	30-AD	70	1-10	28	55	30.05.10.2	30-AD	70	1-10	28	55
30.00.16.2	30	50	1-16	42	50	30.01.16.2	30-AD	70	1-16	42	55	30.05.16.2	30-AD	70	1-16	42	55
30.00.20.2	30	50	2-20	50	50	30.01.20.2	30-AD	70	2-20	50	55	30.05.20.2	30-AD	70	2-20	50	55
						30.01.26.2	30-AD	70	3-30	63	60	30.05.26.2	30-AD	70	3-30	63	60
												30.05.07.22	30-AD	100	1- 7	19	45
						30.01.10.22	30-AD	100	1-10	28	55	30.05.10.22	30-AD	100	1-10	28	55
						30.01.16.22	30-AD	100	1-16	42	55	30.05.16.22	30-AD	100	1-16	42	55
						30.01.20.22	30-AD	100	2-20	63	55	30.05.20.22	30-AD	100	2-20	50	55
												40.05.10.2	40-AD	70	1-10	28	55
						40.01.07.2	40-AD+B	70	1- 7	19	36	40.05.13.21	40-AD+B	70	1-13	35	60
						40.01.10.2	40-AD+B	70	1-10	28	55	40.05.16.2	40-AD	70	1-16	42	62
						40.01.13.2	40-AD+B	70	1-13	35	60	40.05.20.2	40-AD	70	2-20	50	65
40.00.16.2	40	50	1-16	42	65	40.01.16.2	40-AD+B	70	1-16	42	62	40.05.20.21	40-AD+B	70	2-20	50	65
40.00.20.2	40	50	2-20	50	65	40.01.20.2	40-AD+B	70	2-20	50	68	40.05.26.2	40-AD	70	3-30	50	72
40.00.26.2	40	50	3-30	63	65	40.01.26.2	40-AD+B	70	3-30	63	73	40.05.26.21	40-AD+B	70	3-30	63	72
						40.01.34.2	40-AD+B	85	6-34	78	75	40.05.34.21	40-AD+B	85	6-34	78	75
						40.01.07.22	40-AD+B	100	1- 7	19	36	40.05.07.22	40-AD+B	100	1- 7	19	36
						40.01.10.22	40-AD+B	100	1-10	28	60	40.05.10.22	40-AD+B	100	1-10	28	60
						40.01.13.22	40-AD+B	100	1-13	35	60	40.05.13.22	40-AD+B	100	1-13	35	60
						40.01.16.22	40-AD+B	100	1-16	42	62	40.05.16.22	40-AD+B	100	1-16	42	62
						40.01.20.22	40-AD+B	100	2-20	50	66	40.05.20.22	40-AD+B	100	2-20	50	66
						40.01.26.22	40-AD+B	100	3-30	63	73	40.05.26.22	40-AD+B	100	3-30	63	73
						40.01.10.23	40-AD+B	160	1-10	28	60	40.05.10.23	40-AD+B	160	1-10	28	60
						40.01.16.23	40-AD+B	160	1-16	42	62	40.05.16.23	40-AD+B	160	1-16	42	62
						40.01.20.23	40-AD+B	160	2-20	50	63	40.05.20.23	40-AD+B	160	2-20	50	66
						40.01.26.23	40-AD+B	160	3-30	63	73	40.05.26.23	40-AD+B	160	3-30	63	72
												50.05.10.2	50-AD+B	100	1-10	28	75
						50.01.10.2	50-AD+B	100	1-10	28	75	50.05.16.2	50-AD+B	100	1-16	42	75
						50.01.16.2	50-AD+B	100	1-16	42	75	50.05.20.2	50-AD+B	100	2-20	50	75
50.00.20.2	50	50	2-20	50	65	50.01.20.2	50-AD+B	100	2-20	50	75	50.05.26.2	50-AD+B	100	3-30	63	75
50.00.26.2	50	50	3-30	63	65	50.01.26.2	50-AD+B	100	3-30	63	75	50.05.34.2	50-AD+B	100	6-34	78	75
50.00.34.2	50	60	6-34	78	65	50.01.34.2	50-AD+B	100	6-34	78	75	50.05.10.23	50-AD+B	160	1-10	28	75
						50.01.10.23	50-AD+B	160	1-10	28	75	50.05.16.23	50-AD+B	160	1-16	42	75
						50.01.16.23	50-AD+B	160	1-16	42	75	50.05.20.23	50-AD+B	160	2-20	50	75
						50.01.20.23	50-AD+B	160	2-20	50	75	50.05.26.23	50-AD+B	160	3-30	63	75
						50.01.26.23	50-AD+B	160	3-30	63	75						

Spannzangen ER/ESX 11 Spannbereich ø1- 7
Spannzangen ER/ESX 16 Spannbereich ø1-10
Spannzangen ER/ESX 20 Spannbereich ø1-13
Spannzangen ER/ESX 25 Spannbereich ø1-16
Spannzangen ER/ESX 32 Spannbereich ø2-20
Spannzangen ER/ESX 40 Spannbereich ø3-30
Spannzangen ER/ESX 50 Spannbereich ø6-34

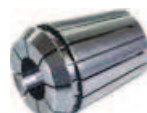

DIN 6499

Collet ER/ESX 11 Clamping range ø1- 7
Collet ER/ESX 16 Clamping range ø1-10
Collet ER/ESX 20 Clamping range ø1-13
Collet ER/ESX 25 Clamping range ø1-16
Collet ER/ESX 32 Clamping range ø2-20
Collet ER/ESX 40 Clamping range ø3-30
Collet ER/ESX 50 Clamping range ø6-34

Spannzangenfutter DIN 6391 für Spannzangen DIN 6388

Collet chuck DIN 6391 for collets DIN 6388

Kegelwinkel AT3, Rundlaufgenauigkeit Steilkegel zu Werkzeugaufnahme < 0,005
Taper angle AT3, Concentricity from the taper to the holding part < 0,005

gewuchtet G 6,3 - 20.000 U/min. DIN 69871 SK 30 + 40, MAS BT 30 + 40
balanced G 6,3 - 20.000 r.p.m. DIN 69871 SK 30 + 40, MAS BT 30 + 40

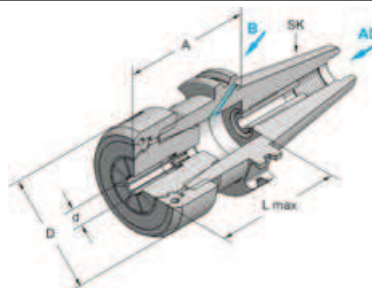

DIN 2080



DIN 69871



MAS BT

Art.-Nr.	SK	A	d	D	L	Art.-Nr.	SK	A	d	D	L	Art.-Nr.	SK	A	d	D	L	
												30.05.16.1	30-AD	70	1-16	43	55	
						40.01.16.10	40-AD+B	70	1-16	43	62	40.05.16.1	40-AD+B	70	1-16	43	62	
						40.01.16.12	40-AD+B	100	1-16	43	62							
40.00.25.1	40	63	2-25	60	74	40.01.25.10	40-AD+B	70	2-25	60	74	40.05.25.1	40-AD+B	70	2-25	60	74	
						40.01.25.12	40-AD+B	100	2-25	60	74							
						40.01.32.10	40-AD+B	90	4-32	72	82	40.05.32.1	40-AD+B	80	4-32	72	82	
50.00.25.1	50	63	2-25	60	74	50.01.25.10	50-AD+B	100	2-25	60	74	50.05.25.1	50-AD+B	100	2-25	60	74	
50.00.32.1	50	70	4-32	72	93	50.01.32.10	50-AD+B	100	4-32	72	93	50.05.32.1	50-AD+B	100	4-32	72	93	

Spannzangen DIN 6388 siehe Seite 76 / Collets DIN 6388 see page 76

Kegelhülse MK DIN 6383 / DIN 6384 mit Anzugsgewinde .55

Reducing adapter MT DIN 6383 / DIN 6384 with retention thread .55

Kegelwinkel AT3, Rundlaufgenauigkeit Steilkegel zu Werkzeugaufnahme < 0,005
Taper angle AT3, Concentricity from the taper to the holding part < 0,005

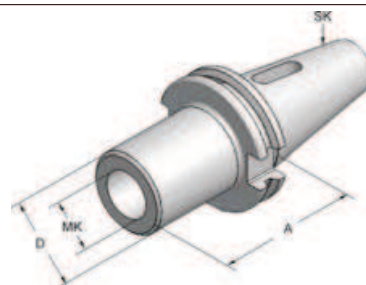

DIN 2080



DIN 69871



MAS BT

Art.-Nr.	SK	A	MK	D	Art.-Nr.	SK	A	MK	D	Art.-Nr.	SK	A	MK	D
					30.01.01.5	30	50	1	28	30.05.01.5	30	50	1	25
					30.01.02.5	30	60	2	42	30.05.02.5	30	60	2	32
					30.01.03.5	30	80	3	50	30.05.03.5	30	80	3	40
40.00.01.5	40	50	1	25	40.01.01.5	40	50	1	25	40.05.01.5	40	50	1	25
40.00.02.5	40	50	2	32	40.01.02.5	40	50	2	32	40.05.02.5	40	50	2	32
40.00.03.5	40	65	3	40	40.01.03.5	40	70	3	40	40.05.03.5	40	70	3	40
40.00.04.5	40	95	4	48	40.01.04.5	40	95	4	48	40.05.04.5	40	95	4	48
50.00.01.5	50	45	1	25	50.01.01.5	50	45	1	25	50.05.01.5	50	45	1	25
50.00.02.5	50	60	2	32	50.01.02.5	50	60	2	32	50.05.02.5	50	60	2	32
50.00.03.5	50	65	3	40	50.01.03.5	50	65	3	40	50.05.03.5	50	65	3	40
50.00.04.5	50	70	4	48	50.01.04.5	50	95	4	48	50.05.04.5	50	95	4	48
50.00.05.5	50	105	5	63	50.01.05.5	50	105	5	63	50.05.05.5	50	105	5	63
40.00.01.55	40	50	1	25	40.01.01.55	40	50	1	25	40.05.01.55	40	50	1	25
40.00.02.55	40	50	2	32	40.01.02.55	40	50	2	32	40.05.02.55	40	50	2	32
40.00.03.55	40	65	3	40	40.01.03.55	40	70	3	40	40.05.03.55	40	70	3	40
40.00.04.55	40	95	4	48	40.01.04.55	40	95	4	48	40.05.04.55	40	95	4	48
50.00.02.55	50	60	2	32	50.01.02.55	50	60	2	32	50.05.02.55	50	60	2	32
50.00.03.55	50	65	3	40	50.01.03.55	50	65	3	40	50.05.03.55	50	65	3	40
50.00.04.55	50	65	4	48	50.01.04.55	50	70	4	48	50.05.04.55	50	70	4	48
50.00.05.55	50	120	5	63	50.01.05.55	50	100	5	63	50.05.05.55	50	100	5	63

Kombi-Aufsteckfräsdorn DIN 6358 Typ .4

Universal arbor DIN 6358 Typ .4

Messerkopfaufnahme DIN 6357 Typ .9

Shell mill adapter for facing cutters DIN 6357 Typ .9

Kegelwinkel AT3, Rundlaufgenauigkeit Steilkegel zu Werkzeugaufnahme < 0,005

Taper angle AT3, Concentricity from the taper to the holding part < 0,005

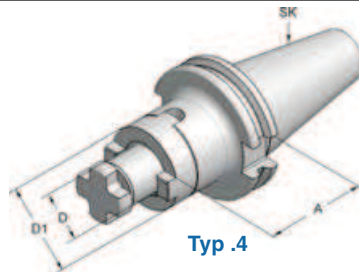

Typ .4

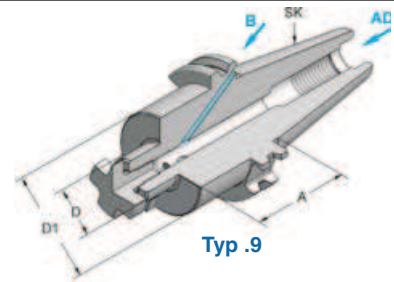

Typ .9



DIN 2080



DIN 69871



MAS BT

Art.-Nr.	SK	A	D	D1	L	Art.-Nr.	SK	A	D	D1	L	Art.-Nr.	SK	A	D	D1	L
30.00.16.4	30	40	16	32	10	30.01.16.4	30	50	16	32	10	30.05.16.4	30	50	16	32	10
30.00.22.4	30	40	22	40	12	30.01.22.4	30	50	22	40	12	30.05.22.4	30	50	22	40	12
30.00.27.4	30	40	27	48	12	30.01.27.4	30	52	27	48	12	30.05.27.4	30	50	27	48	12
40.00.16.4	40	52	16	32	10	40.01.16.4	40	55	16	32	10	40.05.16.4	40	55	16	32	10
40.00.22.4	40	52	22	40	12	40.01.22.4	40	55	22	40	12	40.05.22.4	40	55	22	40	12
40.00.27.4	40	52	27	48	12	40.01.27.4	40	55	27	48	12	40.05.27.4	40	55	27	48	12
40.00.32.4	40	52	32	58	14	40.01.32.4	40	60	32	58	14	40.05.32.4	40	60	32	58	14
40.00.40.4	40	52	40	70	14	40.01.40.4	40	60	40	70	14	40.05.40.4	40	60	40	70	14
						40.01.16.42	40	100	16	32	10	40.05.16.42	40	100	16	32	10
						40.01.22.42	40	100	22	40	12	40.05.22.42	40	100	22	40	12
						40.01.27.42	40	100	27	48	12	40.05.27.42	40	100	27	48	12
						40.01.32.42	40	100	32	58	14	40.05.32.42	40	100	32	58	14
50.00.16.4	50	52	16	32	10	50.01.16.4	50	55	16	32	10	50.05.16.4	50	70	16	32	10
50.00.22.4	50	52	22	40	12	50.01.22.4	50	55	22	40	12	50.05.22.4	50	70	22	40	12
50.00.27.4	50	52	27	48	12	50.01.27.4	50	55	27	48	12	50.05.27.4	50	70	27	48	12
50.00.32.4	50	52	32	58	14	50.01.32.4	50	55	32	58	14	50.05.32.4	50	70	32	58	14
50.00.40.4	50	52	40	70	14	50.01.40.4	50	55	40	70	14	50.05.40.4	50	70	40	70	14
50.00.50.4	50	52	50	90	16	50.01.50.4	50	70	50	90	16	50.05.50.4	50	90	50	90	16
						50.01.16.42	50	100	16	32	10	50.05.16.42	50	100	16	32	10
						50.01.22.42	50	100	22	40	12	50.05.22.42	50	100	22	40	12
						50.01.27.42	50	100	27	48	12	50.05.27.42	50	100	27	48	12
						50.01.32.42	50	100	32	58	14	50.05.32.42	50	100	32	58	14
						50.01.40.42	50	100	40	70	14	50.05.40.42	50	100	40	70	14



DIN 2080



DIN 69871



MAS BT

Art.-Nr.	SK	A	D	D1	Art.-Nr.	SK	A	D	D1	Art.-Nr.	SK	A	D	D1
40.00.16.9	40	30	16	39	40.01.16.9	40-AD+B+C	50	16	39	40.05.16.9	40-AD+B+C	50	16	39
40.00.22.9	40	30	22	49	40.01.22.9	40-AD+B+C	50	22	49	40.05.22.9	40-AD+B+C	50	22	49
40.00.27.9	40	30	27	60	40.01.27.9	40-AD+B+C	50	27	60	40.05.27.9	40-AD+B+C	50	27	60
40.00.32.9	40	30	32	68	40.01.32.9	40-AD+B+C	60	32	68	40.05.32.9	40-AD+B+C	60	32	68
40.00.40.9	40	30	40	88	40.01.40.9	40-AD+B+C	60	40	88	40.05.40.9	40-AD+B+C	60	40	88
50.00.22.9	50	35	22	49	50.01.22.9	50-AD+B+C	60	22	49	50.05.22.9	50-AD+B+C	60	22	49
50.00.27.9	50	35	27	60	50.01.27.9	50-AD+B+C	60	27	60	50.05.27.9	50-AD+B+C	60	27	60
50.00.32.9	50	40	32	68	50.01.32.9	50-AD+B+C	60	32	68	50.05.32.9	50-AD+B+C	60	32	68
50.00.40.9	50	40	40	88	50.01.40.9	50-AD+B+C	70	40	88	50.05.40.9	50-AD+B+C	60	40	88
50.00.60.9	50	70	60	128	50.01.60.9	50-AD+B+C	70	60	128	50.05.60.9	50-AD+B+C	80	60	128

Zylinderschaftaufnahme Weldon DIN 1835 B Holder for straight shank tools Weldon DIN 1835 B

Kegelwinkel AT3, Rundlaufgenauigkeit Steilkegel zu Werkzeugaufnahme < 0,005
Taper angle AT3, Concentricity from the taper to the holding part < 0,005

gewuchtet G 6,3 - 20.000 U/min. DIN 69871 SK 30 + 40, MAS BT 30 + 40
balanced G 6,3 - 20.000 r.p.m. DIN 69871 SK 30 + 40, MAS BT 30 + 40

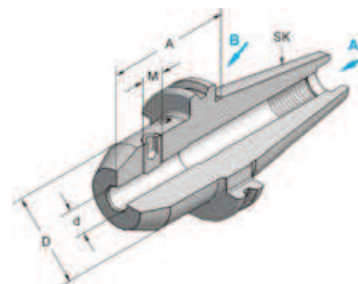

DIN 2080



DIN 69871



MAS BT

DIN 2080						DIN 69871						MAS BT					
Art.-Nr.	SK	A	d	D	M	Art.-Nr.	SK	A	d	D	M	Art.-Nr.	SK	A	d	D	M
30.00.06.6	30	50	6	25	6	30.01.06.6	30-AD	60	6	25	6	30.05.06.60	30-AD	60	6	25	6
30.00.08.6	30	50	8	28	8	30.01.08.6	30-AD	60	8	28	8	30.05.08.60	30-AD	60	8	28	8
30.00.10.6	30	50	10	35	10	30.01.10.6	30-AD	60	10	35	10	30.05.10.60	30-AD	60	10	35	10
30.00.12.6	30	50	12	42	12	30.01.12.6	30-AD	60	12	42	12	30.05.12.60	30-AD	60	12	42	12
						30.01.14.6	30-AD	60	14	44	12	30.05.14.60	30-AD	60	14	44	12
30.00.16.6	30	50	16	48	14	30.01.16.6	30-AD	60	16	48	14	30.05.16.60	30-AD	60	16	48	14
						30.01.18.6	30-AD	60	18	50	14	30.05.18.60	30-AD	60	18	50	14
30.00.20.6	30	50	20	50	16	30.01.20.6	30-AD	60	20	50	16	30.05.20.60	30-AD	60	20	50	16
						30.01.25.6	30-AD	75	25	50	16x1	30.05.25.60	30-AD	75	25	50	16x1
												30.05.06.62	30-AD	100	6	25	6
						40.01.06.06	40-AD	30	6	25	6	30.05.08.62	30-AD	100	8	28	8
						40.01.08.06	40-AD	30	8	28	8	30.05.10.62	30-AD	100	10	35	10
						40.01.10.06	40-AD	30	10	35	10	30.05.12.62	30-AD	100	12	42	12
						40.01.12.06	40-AD	35	12	42	12	30.05.16.62	30-AD	100	16	48	14
						40.01.14.06	40-AD	35	14	44	12	30.05.20.62	30-AD	100	20	52	16
						40.01.16.06	40-AD	35	16	48	14						
						40.01.18.06	40-AD	35	18	50	14	40.05.16.06	40-AD	35	16	48	14
						40.01.20.06	40-AD	35	20	50	16	40.05.20.06	40-AD	35	20	50	16
						40.01.25.06	40-AD	35	25	50	16x1	40.05.25.06	40-AD	35	25	50	16x1
						40.01.32.06	40-AD	35	32	50	16x1						
40.00.06.6	40	50	6	25	6	40.01.06.6	40-AD+B	65	6	25	6	40.05.06.60	40-AD	65	6	25	6
40.00.08.6	40	50	8	28	8	40.01.08.6	40-AD+B	65	8	28	8	40.05.08.60	40-AD	65	8	28	8
40.00.10.6	40	50	10	35	10	40.01.10.6	40-AD+B	65	10	35	10	40.05.10.60	40-AD	65	10	35	10
40.00.12.6	40	50	12	42	12	40.01.12.6	40-AD+B	65	12	42	12	40.05.12.60	40-AD	65	12	42	12
40.00.14.6	40	50	14	44	12	40.01.14.6	40-AD+B	65	14	44	12	40.05.14.60	40-AD	65	14	44	12
40.00.16.6	40	63	16	48	14	40.01.16.6	40-AD+B	65	16	48	14	40.05.16.60	40-AD	65	16	48	14
40.00.18.6	40	63	18	50	14	40.01.18.6	40-AD+B	65	18	50	14	40.05.18.60	40-AD	65	18	50	14
40.00.20.6	40	63	20	50	16	40.01.20.6	40-AD+B	65	20	50	16	40.05.20.60	40-AD	65	20	50	16
40.00.25.6	40	80	25	64	18x2	40.01.25.6	40-AD+B	75	25	64	18x2	40.05.25.60	40-AD	65	25	64	18x2
40.00.32.6	40	80	32	72	20x2	40.01.32.6	40-AD+B	75	32	72	20x2	40.05.32.60	40-AD	75	32	72	20x2
						40.01.40.6	40-AD+B	120	40	80	20x2	40.05.40.60	40-AD+B	120	40	80	20x2
						40.01.06.620	40-AD+B	100	6	25	6	40.05.06.62	40-AD+B	100	6	25	6
						40.01.08.620	40-AD+B	100	8	28	8	40.05.08.62	40-AD+B	100	8	28	8
						40.01.10.620	40-AD+B	100	10	35	10	40.05.10.62	40-AD+B	100	10	35	10
						40.01.12.620	40-AD+B	100	12	42	12	40.05.12.62	40-AD+B	100	12	42	12
						40.01.14.620	40-AD+B	100	14	44	12	40.05.14.62	40-AD+B	100	14	44	12
						40.01.16.620	40-AD+B	100	16	48	14	40.05.16.62	40-AD+B	100	16	48	14
						40.01.18.620	40-AD+B	100	18	50	14	40.05.18.62	40-AD+B	100	18	50	14
						40.01.20.620	40-AD+B	100	20	50	16	40.05.20.62	40-AD+B	100	20	50	16
						40.01.25.620	40-AD+B	100	25	64	18x2	40.05.25.62	40-AD+B	100	25	64	18x2
						40.01.32.620	40-AD+B	100	32	72	20x2	40.05.32.62	40-AD+B	100	32	72	20x2

Zylinderschaftaufnahme Weldon DIN 1835 B

Holder for straight shank tools Weldon DIN 1835 B

Kegelwinkel AT3, Rundlaufgenauigkeit Steilkegel zu Werkzeugaufnahme < 0,005
Taper angle AT3, Concentricity from the taper to the holding part < 0,005

gewuchtet G 6,3 - 20.000 U/min. DIN 69871 SK 40, MAS BT 40
balanced G 6,3 - 20.000 r.p.m. DIN 69871 SK 40, MAS BT 40

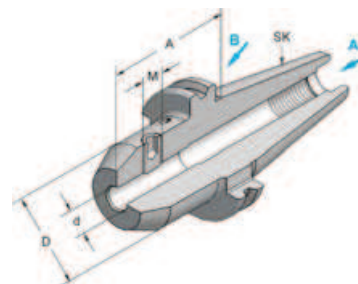

DIN 2080



DIN 69871



MAS BT

Art.-Nr.	SK	A	d	D	M	Art.-Nr.	SK	A	d	D	M	Art.-Nr.	SK	A	d	D	M	
						40.01.06.63	40-AD+B	160	6	25	6	40.05.06.63	40-AD+B	160	6	25	6	
						40.01.08.63	40-AD+B	160	8	28	8	40.05.08.63	40-AD+B	160	8	28	8	
						40.01.10.63	40-AD+B	160	10	35	10	40.05.10.63	40-AD+B	160	10	35	10	
						40.01.12.63	40-AD+B	160	12	42	12	40.05.12.63	40-AD+B	160	12	42	12	
						40.01.16.63	40-AD+B	160	16	44	14	40.05.16.63	40-AD+B	160	16	44	14	
						40.01.20.63	40-AD+B	160	20	48	16	40.05.20.63	40-AD+B	160	20	48	16	
50.00.06.6	50	63	6	25	6	50.01.06.6	50-AD+B	63	6	25	6	50.05.06.60	50-AD+B	63	6	25	6	
50.00.08.6	50	63	8	28	8	50.01.08.6	50-AD+B	63	8	28	8	50.05.08.60	50-AD+B	63	8	28	8	
50.00.10.6	50	63	10	35	10	50.01.10.6	50-AD+B	63	10	35	10	50.05.10.60	50-AD+B	63	10	35	10	
50.00.12.6	50	63	12	42	12	50.01.12.6	50-AD+B	63	12	42	12	50.05.12.60	50-AD+B	80	12	42	12	
50.00.14.6	50	63	14	44	12	50.01.14.6	50-AD+B	63	14	44	12	50.05.14.60	50-AD+B	80	14	44	12	
50.00.16.6	50	63	16	48	14	50.01.16.6	50-AD+B	63	16	48	14	50.05.16.60	50-AD+B	80	16	48	14	
50.00.18.6	50	63	18	50	14	50.01.18.6	50-AD+B	63	18	50	14	50.05.18.60	50-AD+B	80	18	50	14	
50.00.20.6	50	63	20	52	16	50.01.20.6	50-AD+B	63	20	52	16	50.05.20.60	50-AD+B	80	20	52	16	
50.00.25.6	50	80	25	64	18x2	50.01.25.6	50-AD+B	80	25	64	18x2	50.05.25.60	50-AD+B	100	25	64	18x2	
50.00.32.6	50	80	32	72	20x2	50.01.32.6	50-AD+B	100	32	72	20x2	50.05.32.60	50-AD+B	105	32	72	20x2	
50.00.40.6	50	90	40	80	20x2	50.01.40.6	50-AD+B	100	40	80	20x2	50.05.40.60	50-AD+B	110	40	80	20x2	

Bohrfutteraufnahme DIN 238

Drill chuck arbor DIN 238

Kegelwinkel AT3, Rundlaufgenauigkeit Steilkegel zu Werkzeugaufnahme < 0,005
Taper angle AT3, Concentricity from the taper to the holding part < 0,005

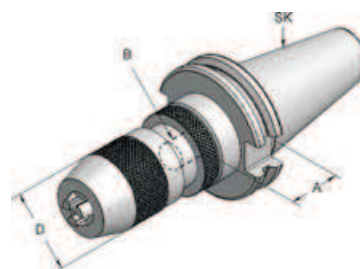

Bohrfutter Drill chuck

287100
289100
290100



DIN 2080



DIN 69871



MAS BT

Art.-Nr.	SK	A	B	D	Art.-Nr.	SK	A	B	D	Art.-Nr.	SK	A	B	D
30.00.12.8	30	15	12	43	30.01.12.8	30	23	12	43	30.05.12.8	30	26	12	43
30.00.16.8	30	17	16	50	30.01.16.8	30	24	16	50	30.05.16.8	30	27	16	50
40.00.12.8	40	15	12	43	40.01.12.8	40	35	12	43	40.05.12.8	40	43	12	43
40.00.16.8	40	17	16	50	40.01.16.8	40	36	16	50	40.05.16.8	40	44	16	50
50.00.16.8	50	20	16	50	50.01.16.8	50	25	16	50	50.05.16.8	50	43	16	50
50.00.18.8	50	20	18	56	50.01.18.8	50	25	18	56	50.05.18.8	50	43	18	56

Bohrfutter / Drill chuck

287100 B12x0,5-10x80

289100 B16x1,0-13x90

290100 B16x2,5-16x95

Zylinderschaftaufnahme Weldon DIN 1835 B mit Kühlkanal Holder for straight shank tools Weldon DIN 1835 B with through tool coolant channel

Kegelwinkel AT3, Rundlaufgenauigkeit Steilkegel zu Werkzeugaufnahme < 0,005
Taper angle AT3, Concentricity from the taper to the holding part < 0,005

gewuchtet G 6,3 - 20.000 U/min. DIN 69871 SK 40, MAS BT 40
balanced G 6,3 - 20.000 r.p.m. DIN 69871 SK 40, MAS BT 40

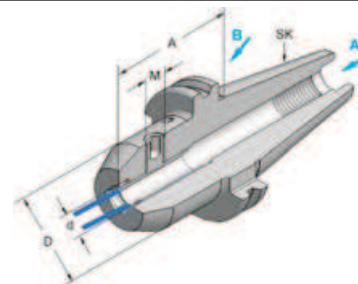

DIN 69871



MAS BT

Art.-Nr.	SK	A	d	D	M	Art.-Nr.	SK	A	d	D	M
40.01.06.66	40-AD+B+C	65	6	25	6	40.05.06.66	40-AD+B+C	65	6	25	6
40.01.08.66	40-AD+B+C	65	8	28	8	40.05.08.66	40-AD+B+C	65	8	28	8
40.01.10.66	40-AD+B+C	65	10	35	10	40.05.10.66	40-AD+B+C	65	10	35	10
40.01.12.66	40-AD+B+C	65	12	42	12	40.05.12.66	40-AD+B+C	65	12	42	12
40.01.14.66	40-AD+B+C	65	14	44	12	40.05.14.66	40-AD+B+C	65	14	44	12
40.01.16.66	40-AD+B+C	65	16	48	14	40.05.16.66	40-AD+B+C	65	16	48	14
40.01.18.66	40-AD+B+C	65	18	50	14	40.05.18.66	40-AD+B+C	65	18	50	14
40.01.20.66	40-AD+B+C	65	20	52	16	40.05.20.66	40-AD+B+C	65	20	52	16
40.01.25.66	40-AD+B+C	75	25	64	18x2	40.05.25.66	40-AD+B+C	75	25	64	18x2
40.01.32.66	40-AD+B+C	75	32	72	20x2	40.05.32.66	40-AD+B+C	75	32	72	20x2
40.01.06.662	40-AD+B+C	100	6	25	6	40.05.06.662	40-AD+B+C	100	6	25	6
40.01.08.662	40-AD+B+C	100	8	28	8	40.05.08.662	40-AD+B+C	100	8	28	8
40.01.10.662	40-AD+B+C	100	10	35	10	40.05.10.662	40-AD+B+C	100	10	35	10
40.01.12.662	40-AD+B+C	100	12	42	12	40.05.12.662	40-AD+B+C	100	12	42	12
40.01.16.662	40-AD+B+C	100	16	48	14	40.05.16.662	40-AD+B+C	100	16	48	14
40.01.20.662	40-AD+B+C	100	20	52	16	40.05.20.662	40-AD+B+C	100	20	52	16
40.01.25.662	40-AD+B+C	100	25	64	18x2	40.05.25.662	40-AD+B+C	100	25	64	18x2
40.01.32.662	40-AD+B+C	100	32	72	20x2	40.05.32.662	40-AD+B+C	100	32	72	20x2
50.01.06.66	50-AD+B+C	100	6	25	6	50.05.06.66	50-AD+B+C	100	6	25	6
50.01.08.66	50-AD+B+C	100	8	28	8	50.05.08.66	50-AD+B+C	100	8	28	8
50.01.10.66	50-AD+B+C	100	10	35	10	50.05.10.66	50-AD+B+C	100	10	35	10
50.01.12.66	50-AD+B+C	100	12	42	12	50.05.12.66	50-AD+B+C	100	12	42	12
50.01.14.66	50-AD+B+C	100	14	44	12	50.05.14.66	50-AD+B+C	100	14	44	12
50.01.16.66	50-AD+B+C	100	16	48	14	50.05.16.66	50-AD+B+C	100	16	48	14
50.01.18.66	50-AD+B+C	100	18	50	14	50.05.18.66	50-AD+B+C	100	18	50	14
50.01.20.66	50-AD+B+C	100	20	52	16	50.05.20.66	50-AD+B+C	100	20	52	16
50.01.25.66	50-AD+B+C	100	25	64	18x2	50.05.25.66	50-AD+B+C	100	25	64	18x2
50.01.32.66	50-AD+B+C	100	32	72	20x2	50.05.32.66	50-AD+B+C	120	32	72	20x2
50.01.40.66	50-AD+B+C	100	40	80	20x2	50.05.40.66	50-AD+B+C	120	40	80	20x2
50.01.10.663	50-AD+B+C	160	10	35	10	50.05.10.663	50-AD+B+C	160	10	35	10
50.01.12.663	50-AD+B+C	160	12	42	12	50.05.12.663	50-AD+B+C	160	12	42	12
50.01.16.663	50-AD+B+C	160	16	48	14	50.05.16.663	50-AD+B+C	160	16	48	14
50.01.20.663	50-AD+B+C	160	20	52	16	50.05.20.663	50-AD+B+C	160	20	52	16
50.01.25.663	50-AD+B+C	160	25	64	18x2	50.05.25.663	50-AD+B+C	160	25	64	18x2

O-Ring muss separat bestellt werden
Sealing ring on sparate order



Art.-Nr.	Typ	Art.-Nr.	Typ
270100	6,0x1,5	276100	18,0x2,5
271100	8,0x1,5	277100	20,0x2,5
272100	10,0x2,0	278100	25,0x3,0
273100	12,0x2,0	279100	32,0x3,0
274100	14,0x2,0	299100	40,0x3,5
275100	16,0x2,5		

Für Werkzeuge mit i.K. muss O-Ring eingesetzt werden
For tools with through coolant a sealing ring must be used

Zylinderschaftaufnahme Whistle-Notch DIN 1835 E Holder for straight shank tools Whistle-Notch DIN 1835 E

Kegelwinkel AT3, Rundlaufgenauigkeit Steilkegel zu Werkzeugaufnahme < 0,005
Taper angle AT3, Concentricity from the taper to the holding part < 0,005

gewuchtet G 6,3 - 20.000 U/min. DIN 69871 SK 40, MAS BT 40
balanced G 6,3 - 20.000 r.p.m. DIN 69871 SK 40, MAS BT 40

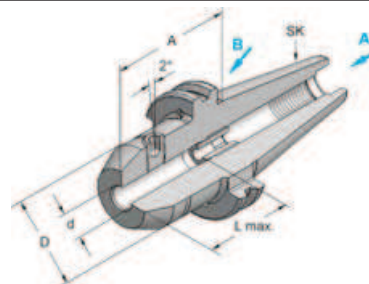

DIN 69871



MAS BT

Art.-Nr.	SK	A	d	D	L	Art.-Nr.	SK	A	d	D	L
40.01.06.65	40-AD+B	65	6	25	38	40.05.06.65	40-AD+B	65	6	25	38
40.01.08.65	40-AD+B	65	8	28	38	40.05.08.65	40-AD+B	65	8	28	38
40.01.10.65	40-AD+B	65	10	35	45	40.05.10.65	40-AD+B	65	10	35	45
40.01.12.65	40-AD+B	65	12	42	52	40.05.12.65	40-AD+B	65	12	42	52
40.01.14.65	40-AD+B	65	14	44	52	40.05.14.65	40-AD+B	65	14	44	52
40.01.16.65	40-AD+B	65	16	48	55	40.05.16.65	40-AD+B	65	16	48	55
40.01.18.65	40-AD+B	65	18	50	55	40.05.18.65	40-AD+B	65	18	50	55
40.01.20.65	40-AD+B	65	20	52	59	40.05.20.65	40-AD+B	65	20	52	59
40.01.25.65	40-AD+B	75	25	63	67	40.05.25.65	40-AD+B	75	25	63	67
40.01.32.65	40-AD+B	75	32	63	68	40.05.32.65	40-AD+B	75	32	63	68
40.01.06.652	40-AD+B	100	6	25	38	40.05.06.652	40-AD+B	100	6	25	38
40.01.08.652	40-AD+B	100	8	28	38	40.05.08.652	40-AD+B	100	8	28	38
40.01.10.652	40-AD+B	100	10	35	45	40.05.10.652	40-AD+B	100	10	35	45
40.01.12.652	40-AD+B	100	12	42	52	40.05.12.652	40-AD+B	100	12	42	52
40.01.14.652	40-AD+B	100	14	44	52	40.05.14.652	40-AD+B	100	14	44	52
40.01.16.652	40-AD+B	100	16	48	55	40.05.16.652	40-AD+B	100	16	48	55
40.01.20.652	40-AD+B	100	20	52	59	40.05.20.652	40-AD+B	100	20	52	59
50.01.06.65	50-AD+B	63	6	25	38	50.05.06.65	50-AD+B	63	6	25	38
50.01.08.65	50-AD+B	63	8	28	38	50.05.08.65	50-AD+B	63	8	28	38
50.01.10.65	50-AD+B	63	10	35	45	50.05.10.65	50-AD+B	63	10	35	45
50.01.12.65	50-AD+B	63	12	42	52	50.05.12.65	50-AD+B	80	12	42	52
50.01.14.65	50-AD+B	63	14	44	52	50.05.14.65	50-AD+B	80	14	44	52
50.01.16.65	50-AD+B	63	16	48	55	50.05.16.65	50-AD+B	80	16	48	55
50.01.18.65	50-AD+B	63	18	50	55	50.05.18.65	50-AD+B	80	18	50	55
50.01.20.65	50-AD+B	63	20	52	59	50.05.20.65	50-AD+B	80	20	52	59
50.01.25.65	50-AD+B	80	25	63	67	50.05.25.65	50-AD+B	100	25	63	67
50.01.32.65	50-AD+B	100	32	63	68	50.05.32.65	50-AD+B	105	32	63	68

Stellhülseaufnahme nach DIN 6327 Adapter for setting sleeves to DIN 6327

Kegelwinkel AT3, Rundlaufgenauigkeit Steilkegel zu Werkzeugaufnahme < 0,005
Taper angle AT3, Concentricity from the taper to the holding part < 0,005

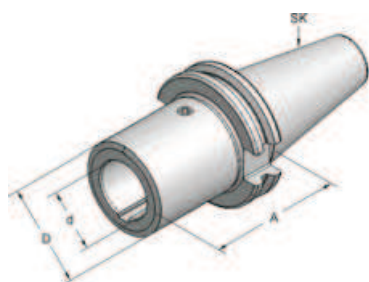

DIN 69871



MAS BT

Art.-Nr.	SK	A	d	D	Art.-Nr.	SK	A	d	D
40.01.28.7	40-AD	70	28	41	40.05.28.7	40-AD	70	28	41
40.01.36.7	40-AD	120	36	50	40.05.36.7	40-AD	120	36	50
50.01.28.7	50-AD	100	28	50	50.05.28.7	50-AD	100	28	50
50.01.36.7	50-AD	100	36	60	50.05.36.7	50-AD	100	36	60
50.01.48.7	50-AD	100	48	80	50.05.48.7	50-AD	100	48	80

NC-Bohrfutter für Rechts- und Linkslauf

CNC-Drill chucks for clockwise and anti-clockwise rotation

Kegelwinkel AT3, Rundlaufgenauigkeit Steilkegel zu Werkzeugaufnahme < 0,04
Taper angle AT3, Concentricity from the taper to the holding part < 0,04

gewuchtet G 6,3 - 8.000 U/min.
balanced G 6,3 - 8.000 r.p.m.

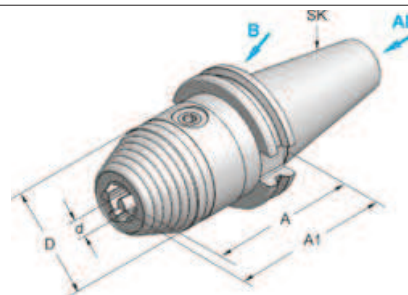

DIN 2080



DIN 69871



MAS BT

Art.-Nr.	SK	A	A1	d	D	Art.-Nr.	SK	A	A1	d	D	Art.-Nr.	SK	A	A1	d	D
40.00.13	40	84	94	1-13	50	30.01.08	30	70	73	1- 8	36	30.05.08	30	73	76	1- 8	36
40.00.16	40	84	96	3-16	57	40.01.13	40	90	100	1-13	50	40.05.13	40	98	108	1-13	50
						40.01.16	40	90	102	3-16	57	40.05.16	40	98	110	3-16	57
						40.01.13k	40-AD+B	90	100	1-13	50	40.05.13k	40-AD+B	98	108	1-13	50
						40.01.16k	40-AD+B	90	102	3-16	57	40.05.16k	40-AD+B	98	110	3-16	57
50.00.13	50	94	104	1-13	50	50.01.13	50	90	100	1-13	50	50.05.13	50	108	118	1-13	50
50.00.16	50	97	109	3-16	57	50.01.16	50	90	102	3-16	57	50.05.16	50	108	120	3-16	57
						50.01.13k	50-AD+B	90	100	1-13	50	50.05.13k	50-AD+B	108	118	1-13	50
						50.01.16k	50-AD+B	90	102	3-16	57	50.05.16k	50-AD+B	108	120	3-16	57

Dehnspannfutter

Expansion chuck

Kegelwinkel AT3, Rundlaufgenauigkeit Steilkegel zu Werkzeugaufnahme < 0,003
Taper angle AT3, Concentricity from the taper to the holding part < 0,003

gewuchtet G 6,3 - 20.000 U/min.
balanced G 6,3 - 20.000 r.p.m.

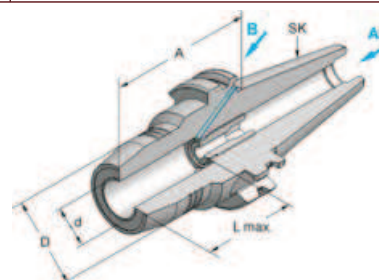

Zwischenhülse
Sleeves



DIN 69871



MAS BT

Art.-Nr.	Typ	Art.-Nr.	SK	A	d	D	L	Art.-Nr.	SK	A	d	D	L
203197	GZB-S 20/03	40.01.06.70	40-AD+B	80,5	6	26	37	40.05.06.70	40-AD+B	90	6	26	37
203198	GZB-S 20/04	40.01.08.70	40-AD+B	80,5	8	28	37	40.05.08.70	40-AD+B	90	8	28	37
203199	GZB-S 20/05	40.01.10.70	40-AD+B	80,5	10	30	37	40.05.10.70	40-AD+B	90	10	30	37
203200	GZB-S 20/06	40.01.12.70	40-AD+B	80,5	12	32	37	40.05.12.70	40-AD+B	90	12	32	37
203201	GZB-S 20/08	40.01.16.70	40-AD+B	80,5	16	38	37	40.05.16.70	40-AD+B	90	16	38	37
203202	GZB-S 20/10	40.01.20.70	40-AD+B	80,5	20	42	37	40.05.20.70	40-AD+B	90	20	42	37
203203	GZB-S 20/12	40.01.20.71	40-AD+B	64,5	20	49	37	40.05.20.71	40-AD+B	72,5	20	49	37
203204	GZB-S 20/14	40.01.25.70	40-AD+B	80,5	25	55	37						
203205	GZB-S 20/16	40.01.32.70	40-AD+B	80,5	32	63	37	40.05.32.70	40-AD+B	83	32	63	37
204320	GZB-S 32/06												
204321	GZB-S 32/08	50.01.20.70	50-AD+B	80,5	20	42	37	50.05.20.70	50-AD+B	90	20	42	37
204322	GZB-S 32/10	50.01.32.71	50-AD+B	81,0	32	72	37	50.05.32.70	50-AD+B	90	32	72	37
204323	GZB-S 32/12												
204324	GZB-S 32/14												
204325	GZB-S 32/16												
204326	GZB-S 32/18												
204327	GZB-S 32/20	204370	GZB-S 12/03					204373	GZB-S 12/06				
204328	GZB-S 32/25	204371	GZB-S 12/04					204374	GZB-S 12/08				
		204372	GZB-S 12/05					204375	GZB-S 12/10				

Schrumpffutter POWER-FLASH Typ .36

Shrinking chuck POWER-FLASH Type .36

Kegelwinkel AT3, Rundlaufgenauigkeit Steilkegel zu Werkzeugaufnahme < 0,005
Taper angle AT3, Concentricity from the taper to the holding part < 0.005

gewuchtet G 6,3 - 20.000 U/min.
balanced G 6,3 - 20.000 r.p.m.

Verschluss der Kühlmittelzufuhr
für Werkzeuge mit Innenkühlung

Seal of the coolant supply
for tools with internal cooling

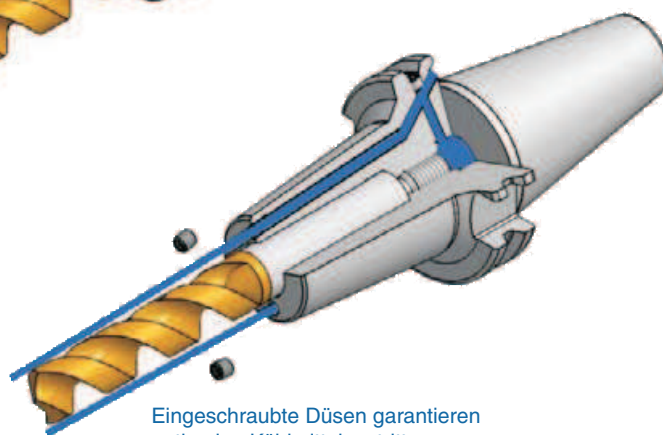
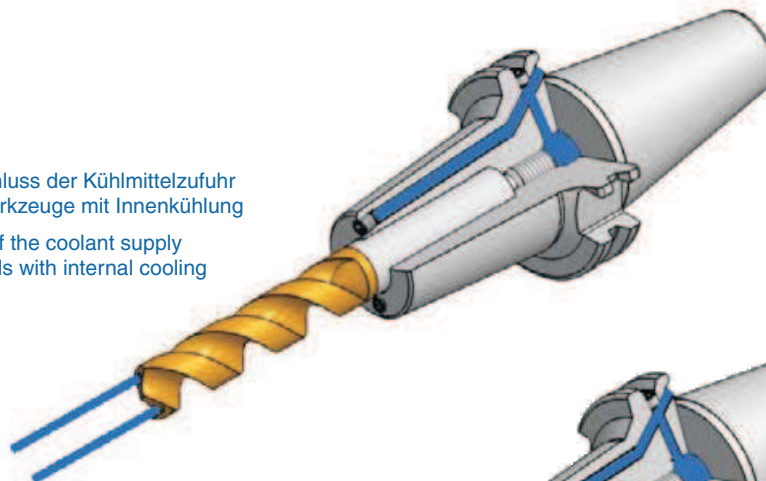

Eingeschraubte Düsen garantieren
optimalen Kühlmittelaustritt
- kein Gießkanneneffekt wie bei der Bohrung

Screwed in coolant nozzles guarantee
the best possible coolant flow
- no watering-can effect like in the case before

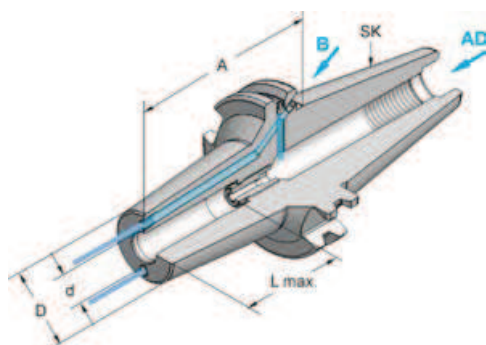

DIN 69871

MAS BT

Art.-Nr.	SK	A	d	D	L	Art.-Nr.	SK	A	d	D	L
40.01.06.36	40-AD+B	80	6	22	40	40.05.06.36	40-AD+B	80	6	22	22
40.01.08.36	40-AD+B	80	8	24	40	40.05.08.36	40-AD+B	80	8	24	24
40.01.10.36	40-AD+B	80	10	26	42	40.05.10.36	40-AD+B	80	10	26	26
40.01.12.36	40-AD+B	80	12	28	47	40.05.12.36	40-AD+B	80	12	28	28
40.01.14.36	40-AD+B	80	14	30	47	40.05.14.36	40-AD+B	80	14	30	30
40.01.16.36	40-AD+B	80	16	32	50	40.05.16.36	40-AD+B	80	16	32	32
40.01.18.36	40-AD+B	80	18	34	50	40.05.18.36	40-AD+B	80	18	34	34
40.01.20.36	40-AD+B	80	20	36	52	40.05.20.36	40-AD+B	80	20	36	36
40.01.25.36	40-AD+B	90	25	42	58	40.05.25.36	40-AD+B	90	25	42	42
50.01.06.36	50-AD+B	100	6	22	40	50.05.06.36	50-AD+B	100	6	22	40
50.01.08.36	50-AD+B	100	8	24	40	50.05.08.36	50-AD+B	100	8	24	40
50.01.10.36	50-AD+B	100	10	26	42	50.05.10.36	50-AD+B	100	10	26	42
50.01.12.36	50-AD+B	100	12	28	47	50.05.12.36	50-AD+B	100	12	28	47
50.01.14.36	50-AD+B	100	14	30	47	50.05.14.36	50-AD+B	100	14	30	47
50.01.16.36	50-AD+B	100	16	32	50	50.05.16.36	50-AD+B	100	16	32	50
50.01.20.36	50-AD+B	100	20	36	52	50.05.20.36	50-AD+B	100	20	36	52
50.01.25.36	50-AD+B	100	25	42	58	50.05.25.36	50-AD+B	100	25	42	58
50.01.32.36	50-AD+B	100	32	49	58	50.05.32.36	50-AD+B	100	32	49	58
Sonderausführungen auf Anfrage / Special executions on inquiry						Sonderausführungen auf Anfrage / Special executions on inquiry					

Schrumpffutter POWER-FLASH high-speed
Shrinking chuck POWER-FLASH high-speed

Kühlmittelzufuhr über Kühlkanäle in der Bohrung
Konzentrierte Kühlmittelzufuhr bis 20.000 U/min zur Werkzeugschneide
Coolant supply through coolant channels in the boring
Concentrated coolant supply up to 20.000 r.p.m. to the cutting edge

gewuchtet G 6,3 - 20.000 U/min.
balanced G 6,3 - 20.000 r.p.m.



SK 40 DIN 69871
MAS BT 40
ø3 - ø32

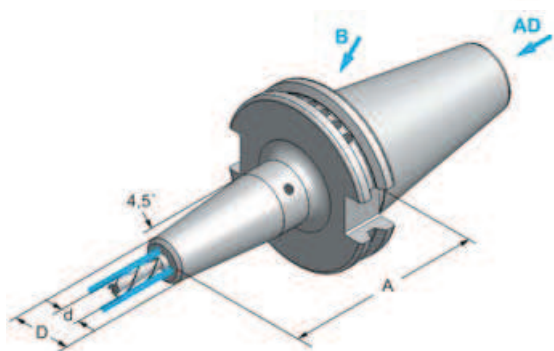

DIN 69871

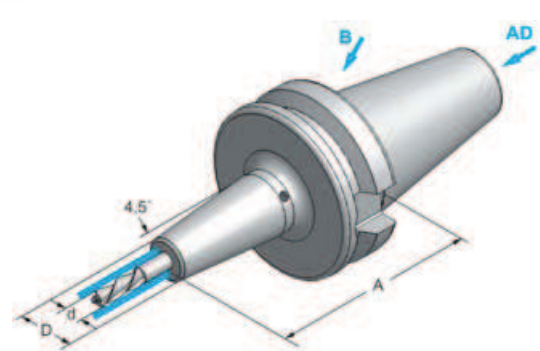

MAS BT

Art.-Nr.	Typ	A	d	D	ik	Art.-Nr.	Typ	A	d	D	ik
40.01.03.37	TC40x03SCx 80-AD+B	80	3	10	2	40.05.03.37	BT40x03SCx 80-AD+B	80	3	10	2
40.01.04.37	TC40x04SCx 80-AD+B	80	4	11	2	40.05.04.37	BT40x04SCx 80-AD+B	80	4	11	2
40.01.05.37	TC40x05SCx 80-AD+B	80	5	14	2	40.05.05.37	BT40x05SCx 80-AD+B	80	5	14	2
40.01.06.37	TC40x06SCx 80-AD+B	80	6	21	3	40.05.06.37	BT40x06SCx 80-AD+B	80	6	21	3
40.01.08.37	TC40x08SCx 80-AD+B	80	8	21	3	40.05.08.37	BT40x08SCx 80-AD+B	80	8	21	3
40.01.10.37	TC40x10SCx 80-AD+B	80	10	24	3	40.05.10.37	BT40x10SCx 80-AD+B	80	10	24	3
40.01.12.37	TC40x12SCx 80-AD+B	80	12	24	3	40.05.12.37	BT40x12SCx 80-AD+B	80	12	24	3
40.01.16.37	TC40x16SCx 80-AD+B	80	16	26	3	40.05.16.37	BT40x16SCx 80-AD+B	80	16	26	3
40.01.20.37	TC40x20SCx 80-AD+B	80	20	33	3	40.05.20.37	BT40x20SCx 80-AD+B	80	20	33	3
40.01.25.37	TC40x25SCx100-AD+B	100	25	44	3	40.05.25.37	BT40x25SCx100-AD+B	100	25	44	3
40.01.32.37	TC40x32SCx100-AD+B	100	32	44	3	40.05.32.37	BT40x32SCx100-AD+B	100	32	44	3

Schrumpffutter ohne Kühlkanal Typ .31+.32+.33 Shrinking chuck without coolant channel Typ .31+.32+.33

Kegelwinkel AT3, Rundlaufgenauigkeit Steilkegel zu Werkzeugaufnahme < 0,005
Taper angle AT3, Concentricity from the taper to the holding part < 0,005

gewuchtet G 6,3 - 20.000 U/min.
balanced G 6,3 - 20.000 r.p.m.

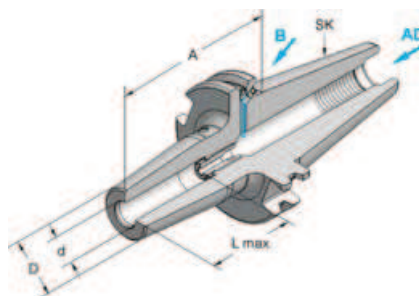

DIN 69871						DIN 69871						MAS BT						
Art.-Nr.	SK	A	d	D	L	Art.-Nr.	SK	A	d	D	L	Art.-Nr.	SK	A	d	D	L	
40.01.03.31	40-AD+B	80	3	10	20	30.01.03.31	30	70	3	10	20	30.05.03.31	30	70	3	10	20	
40.01.04.31	40-AD+B	80	4	13	20	30.01.04.31	30	70	4	13	20	30.05.04.31	30	70	4	13	20	
40.01.05.31	40-AD+B	80	5	13	25	30.01.05.31	30	70	5	13	25	30.05.05.31	30	70	5	13	25	
40.01.06.31	40-AD+B	80	6	21	40	30.01.06.31	30	70	6	21	40	30.05.06.31	30	70	6	21	40	
40.01.08.31	40-AD+B	80	8	21	40	30.01.08.31	30	70	8	21	40	30.05.08.31	30	70	8	21	40	
40.01.10.31	40-AD+B	80	10	24	45	30.01.10.31	30	70	10	24	45	30.05.10.31	30	70	10	24	45	
40.01.12.31	40-AD+B	80	12	24	50	30.01.12.31	30	70	12	24	50	30.05.12.31	30	70	12	24	50	
40.01.14.31	40-AD+B	80	14	27	50	30.01.14.31	30	70	14	27	50	30.05.14.31	30	70	14	27	50	
40.01.16.31	40-AD+B	80	16	27	55	30.01.16.31	30	70	16	27	55	30.05.16.31	30	70	16	27	55	
40.01.18.31	40-AD+B	80	18	33	55													
40.01.20.31	40-AD+B	80	20	33	57	50.01.06.31	50	80	6	21	40	40.05.03.31	40-AD+B	80	3	10	20	
40.01.25.31	40-AD+B	100	25	44	65	50.01.08.31	50	80	8	21	40	40.05.04.31	40-AD+B	80	4	13	20	
40.01.32.31	40-AD+B	100	32	44	65	50.01.10.31	50	80	10	24	45	40.05.05.31	40-AD+B	80	5	13	25	
						50.01.12.31	50	80	12	24	50	40.05.06.31	40-AD+B	80	6	21	40	
40.01.06.32	40-AD+B	130	6	21	40	50.01.14.31	50	80	14	27	50	40.05.08.31	40-AD+B	80	8	21	40	
40.01.08.32	40-AD+B	130	8	21	40	50.01.16.31	50	80	16	27	55	40.05.10.31	40-AD+B	80	10	24	45	
40.01.10.32	40-AD+B	130	10	24	45	50.01.20.31	50	80	20	33	57	40.05.12.31	40-AD+B	80	12	24	50	
40.01.12.32	40-AD+B	130	12	24	50	50.01.25.31	50	100	25	44	65	40.05.14.31	40-AD+B	80	14	27	50	
40.01.16.32	40-AD+B	130	16	27	55	50.01.32.31	50	100	32	44	65	40.05.16.31	40-AD+B	80	16	27	55	
40.01.20.32	40-AD+B	130	20	33	57							40.05.18.31	40-AD+B	80	18	33	55	
40.01.25.32	40-AD+B	130	25	44	65	50.01.06.32	50	130	6	21	40	40.05.20.31	40-AD+B	80	20	33	57	
40.01.32.32	40-AD+B	130	32	44	65	50.01.08.32	50	130	8	21	40	40.05.25.31	40-AD+B	100	25	44	65	
						50.01.10.32	50	130	10	24	45	40.05.32.31	40-AD+B	100	32	44	65	
40.01.06.33	40-AD+B	160	6	21	40	50.01.12.32	50	130	12	24	50	Steilkegel 25 mit Plananlage Collet chuck with plane face						
40.01.08.33	40-AD+B	160	8	21	40	50.01.14.32	50	130	14	27	50							
40.01.10.33	40-AD+B	160	10	24	45	50.01.16.32	50	130	16	27	55	Art.-Nr.	SK	A	d	D	L	
40.01.12.33	40-AD+B	160	12	24	50	50.01.20.32	50	130	20	33	57	25.01.03.31	25	60	3	10	20	
40.01.14.33	40-AD+B	160	14	27	50	50.01.25.32	50	130	25	44	65	25.01.04.31	25	60	4	13	20	
40.01.16.33	40-AD+B	160	16	27	55	50.01.32.32	50	130	32	44	65	25.01.06.31	25	60	6	21	40	
40.01.18.33	40-AD+B	160	18	33	55							25.01.08.31	25	60	8	21	40	
40.01.20.33	40-AD+B	160	20	33	57							25.01.10.31	25	60	10	21	45	

Werkzeugaufnahmen zur Kühlmittel bzw. Luftzufuhr Toolholder for coolant-and air supply

Kegelwinkel AT3, Rundlaufgenauigkeit Steilkegel zu Werkzeugaufnahme < 0,005
Taper angle AT3, Concentricity from the taper to the holding part < 0,005

max. U/min 3000 max. U/min 3000
Kühlmitteldruck max. 6 bar Coolant pressure max. 6 bar
Luftdruck max. 4 bar Air pressure max. 4 bar

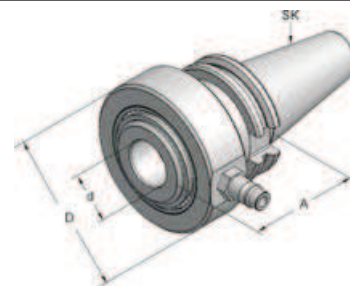

DIN 2080

Art.-Nr.	SK	A	d	D
40.00.25.68	40	50	25	80
40.00.32.68	40	50	32	80
50.00.25.68	50	50	25	80
50.00.32.68	50	50	32	80



DIN 69871

Art.-Nr.	SK	A	d	D
40.01.25.68	40	65	25	80
40.01.32.68	40	65	32	80
50.01.25.68	50	65	25	80
50.01.32.68	50	65	32	80



MAS BT

Art.-Nr.	SK	A	d	D
40.05.25.68	40	58	25	80
40.05.32.68	40	58	32	80
50.05.25.68	50	65	25	80
50.05.32.68	50	65	32	80



DIN 69871

Art.-Nr.	SK	A	d	D
40.01.20.28	40	100	2-20	80

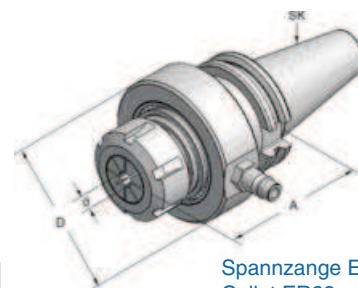

Spannzange ER32
Collet ER32

Pendelhalter, achsparallel ausgleichend einstellbar, mit auswechselbaren Einsätzen Floating holder with compensation adjustment parallel to the axis, with interchangeable cartridges



Abb. mit Einsatz 101101 ER25
Picture with insert 101101 ER25



DIN 69871

Art.-Nr.	SK	A	d	D
40.01.70.350	40-AD+B	105	2-16	42
50.01.70.350	50-AD+B	105	2-16	42

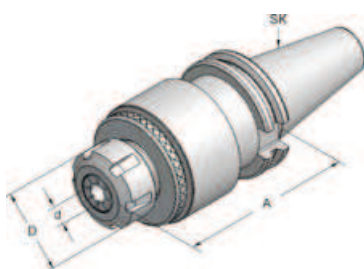

MAS BT

Art.-Nr.	SK	Ad	D
40.05.70.350	40-AD+B	105	2-16 42
50.05.70.350	50-AD+B	105	2-16 42

Einsatz für Pendelhalter Insert for floating holder



Art.-Nr.	Typ	Art.-Nr.	Typ	Art.-Nr.	Typ
101101	Einsatz/Insert ER25/430E	105101	Einsatz/Insert B ø16	109101	Einsatz/Insert C-MK2
102101	Einsatz/Insert DA180/419E	107101	Einsatz/Insert B ø20		
		108101	Einsatz/Insert B ø25		

Aufnahme für Einschraubfräser Adapter for end mills with thread shank

Kegelwinkel AT3, Rundlaufgenauigkeit Steilkegel zu Werkzeugaufnahme < 0,005
Taper angle AT3, Concentricity from the taper to the holding part < 0,005

gewuchtet G 6,3 - 20.000 U/min.
balanced G 6,3 - 20.000 r.p.m.

Sonderausführungen auf Anfrage
Special executions on inquiry

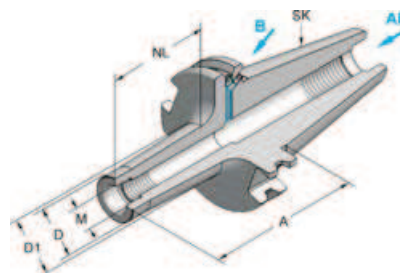

DIN 69871



MAS BT 40

Art.-Nr.	Typ	M	A	NL	D	D1	Art.-Nr.	Typ	M	A	NL	D	D1
40.01.06.025	TC40xM 6x25-AD+B	6	52	25	9,7	10	40.05.06.025	BT40xM 6x25-AD+B	6	60	25	9,7	10
40.01.06.050	TC40xM 6x50-AD+B	6	77	50	9,7	20	40.05.06.050	BT40xM 6x50-AD+B	6	85	50	9,7	20
40.01.06.075	TC40xM 6x75-AD+B	6	102	75	9,7	23	40.05.06.075	BT40xM 6x75-AD+B	6	110	75	9,7	23
40.01.08.025	TC40xM 8x25-AD+B	8	52	25	13	15	40.05.08.025	BT40xM 8x25-AD+B	8	60	25	13	15
40.01.08.050	TC40xM 8x50-AD+B	8	77	50	13	23	40.05.08.050	BT40xM 8x50-AD+B	8	85	50	13	23
40.01.08.075	TC40xM 8x75-AD+B	8	102	75	13	23	40.05.08.075	BT40xM 8x75-AD+B	8	110	75	13	23
40.01.10.025	TC40xM10x25-AD+B	10	52	25	18	20	40.05.10.025	BT40xM10x25-AD+B	10	60	25	18	20
40.01.10.050	TC40xM10x50-AD+B	10	77	50	18	25	40.05.10.050	BT40xM10x50-AD+B	10	85	50	18	25
40.01.10.075	TC40xM10x75-AD+B	10	102	75	18	28	40.05.10.075	BT40xM10x75-AD+B	10	110	75	18	28
40.01.12.025	TC40xM12x25-AD+B	12	52	25	21	24	40.05.12.025	BT40xM12x25-AD+B	12	60	25	21	24
40.01.12.050	TC40xM12x50-AD+B	12	77	50	21	24	40.05.12.050	BT40xM12x50-AD+B	12	85	50	21	24
40.01.12.075	TC40xM12x75-AD+B	12	102	75	21	31	40.05.12.075	BT40xM12x75-AD+B	12	110	75	21	31
40.01.16.025	TC40xM16x25-AD+B	16	52	25	29	34	40.05.16.025	BT40xM16x25-AD+B	16	60	25	29	34
40.01.16.050	TC40xM16x50-AD+B	16	77	50	29	34	40.05.16.050	BT40xM16x50-AD+B	16	85	50	29	34
40.01.16.075	TC40xM16x75-AD+B	16	102	75	29	34	40.05.16.075	BT40xM16x75-AD+B	16	110	75	29	34

Gewindeschneidfutter für Spannzangen ER/ESX Tapping head for collets ER/ESX

Längenausgleich auf Druck + Zug
Flexible position for compression and tension

Längenausgleich auf Druck + Zug
Flexible position for compression and tension

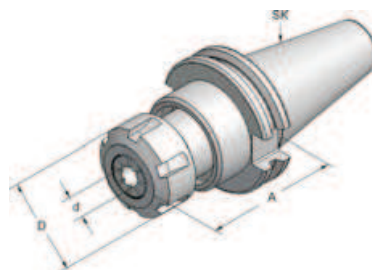
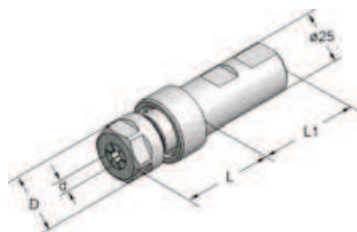

DIN 2080



DIN 69871



MAS BT

Art.-Nr.	SK	A	d	D	Art.-Nr.	SK	A	d	D	Art.-Nr.	SK	A	d	D
40.00.12.13	40	55	1-10	28	30.01.12.13	30	70	1-10	28	30.05.20.13	30	93	1-10	42
40.00.20.13	40	74	2-16	42						40.05.12.13	40	65	1-10	28
40.00.24.13	40	94	3-20	50	40.01.12.13	40	65	1-10	28	40.05.20.13	40	82	2-16	42
50.00.20.13	50	90	2-16	50	40.01.20.13	40	78	2-16	42	40.05.24.13	40	98	3-20	50
50.00.33.13	50	90	4-30	63	40.01.24.13	40	94	3-20	50	40.05.33.13	40	115	4-30	63
					40.01.33.13	40	115	4-30	63					
					45.01.20.13	45	78	2-16	42	45.05.20.13	45	98	2-16	42
					45.01.33.13	45	102	4-30	63	45.05.33.13	45	95	4-30	63
					50.01.20.13	50	100	2-16	42	50.05.20.13	50	100	2-16	42
					50.01.33.13	50	102	4-30	63	50.05.33.13	50	100	4-30	63



Weldon 25

Spannzange ER16 ø1-10 für M2-M12, ER25 ø2-16 für M4-M20, ER32 ø3-20 für M6-M24, ER40 ø4-30 für M8-M33
Collet ER16 ø1-10 for M2-M12, ER25 ø2-16 for M4-M20, ER32 ø3-20 for M6-M24, ER40 ø4-30 for M8-M33

Gewindeschneid-Schnellwechselfutter mit elastischem Längenausgleich auf Druck + Zug

Thread cutting quick-change chuck
with smooth-action length compensation for pressure and tension

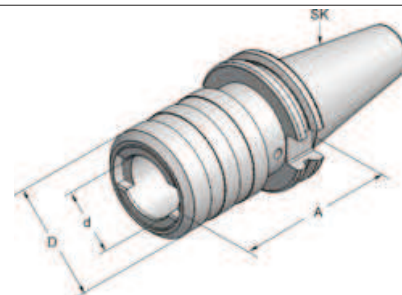

Gr.1 M 3 - M 12		DIN 69871					MAS BT				
Art.-Nr.	Typ	Art.-Nr.	SK	A	d	D	Art.-Nr.	SK	A	d	D
100035	ø 3,50-M3+M4	30.01.12.130	30	65	19	38	30.05.12.130	30	62	19	38
100045	ø 4,50-M4+M6										
100060	ø 6,00-M5+M6+M8	40.01.12.130	40	59	19	38	40.05.12.130	40	65	19	38
100070	ø 7,00-M7+M9+M10										
100080	ø 8,00-M8+M11	50.01.12.130	50	50	19	38	50.05.12.130	50	80	19	38
100090	ø 9,00-M9+M12										
100100	ø10,00-M10										
Gr.2 M 8 - M 20											
200080	ø 8,00-M8+M11	30.01.20.130	30	103	31	54	30.05.20.130	30	95	31	54
200090	ø 9,00-M9+M12										
200100	ø10,00-M10	40.01.20.130	40	97	31	54	40.05.20.130	40	93	31	54
200110	ø11,00-M14										
200120	ø12,00-M12+M16	50.01.20.130	50	82	31	54	50.05.20.130	50	80	31	54
200140	ø14,00-M18										
200160	ø16,00-M20										
Gr.3 M 14 - M 33											
300110	ø11,00-M14	40.01.33.130	30	134	48	78	40.05.33.130	40	126	48	78
300120	ø12,00-M12+M16										
300140	ø14,00-M18	50.01.33.130	50	134	48	78	50.05.33.130	50	142	48	78
300160	ø16,00-M20										
300180	ø18,00-M22+M24										
300200	ø20,00-M27+M30										
300220	ø22,00-M33										

Reduziereinsätze für Werkzeugschäfte nach DIN 1835 Form B + Form E Reducing bushings for toolshanks DIN 1835 B + E

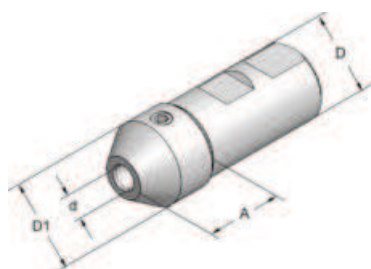

Weldon					Whistle-Notch				
Art.-Nr.	A	d	D	D1	Art.-Nr.	A	d	D	D1
437101	29	6	20	25	441101	29	6	20	25
438101	29	8	20	28	442101	29	8	20	28
439101	29	10	20	35	443101	29	10	20	35
440101	35	12	20	42	444101	35	12	20	42
421101	27	6	32	25	429101	27	6	32	25
422101	27	8	32	28	430101	27	8	32	28
423101	30	10	32	35	431101	30	10	32	35
424101	35	12	32	42	432101	35	12	32	42
425101	35	14	32	44	433101	35	14	32	44
426101	38	16	32	48	434101	38	16	32	48
427101	38	18	32	50	435101	38	18	32	50
428101	40	20	32	52	436101	40	20	32	52

Anzugsbolzen DIN 2080 Retention knobs DIN 2080

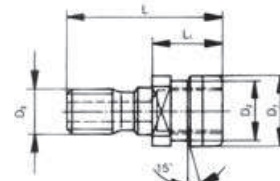

Art.-Nr.	Typ	D1	D2	D3	L	L1	Art.-Nr.	Typ	D1	D2	D3	L	L1
40.16.14	40xDIN 2080	25,3	21,0	M16	53	25,1	50.24.14	50xDIN 2080	39,6	32,0	M24	65	25,1
40.16.142	40xDIN 2080-MK2	25,3	21,0	M10	100	25,1	50.24.142	50xDIN 2080-MK2	39,6	32,0	M10	145	25,1
40.16.143	40xDIN 2080-MK3	25,3	21,0	M12	103	25,1	50.24.143	50xDIN 2080-MK3	39,6	32,0	M12	135	25,1
40.16.144	40xDIN 2080-MK4	25,3	21,0	M16	115	25,1	50.24.144	50xDIN 2080-MK4	39,6	32,0	M16	135	25,1
							50.24.145	50xDIN 2080-MK5	39,6	32,0	M20	135	25,1

Anzugsbolzen DIN 69872 Retention knobs DIN 69872

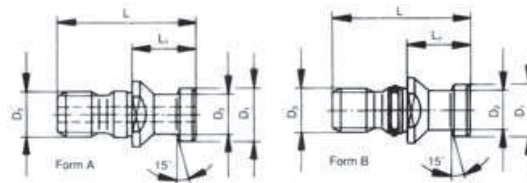

Art.-Nr.	Typ	D1	D2	D3	L	L1	Art.-Nr.	Typ	D1	D2	D3	L	L1
30.12.1	30xDIN 69872-A	13,0	9,0	M12	44	24	30.12.102	30xDIN 69872-MK2	13,0	9,0	M10	90	24
40.16.1	40xDIN 69872-A	19,0	14,0	M16	54	26	30.12.103	30xDIN 69872-MK3	13,0	9,0	M12	95	24
50.24.1	50xDIN 69872-A	28,0	21,0	M24	74	34	40.16.102	40xDIN 69872-MK2	19,0	14,0	M10	101	26
30.12.11	30xDIN 69872-B	13,0	9,0	M12	44	24	40.16.103	40xDIN 69872-MK3	19,0	14,0	M12	104	26
40.16.11	40xDIN 69872-B	19,0	14,0	M16	54	26	40.16.104	40xDIN 69872-MK4	19,0	14,0	M16	116	26
50.24.11	50xDIN 69872-B	28,0	21,0	M24	74	34	50.24.102	50xDIN 69872-MK2	28,0	21,0	M10	154	34
							50.24.103	50xDIN 69872-MK3	28,0	21,0	M12	144	34
40.16.15	40xDIN 69872-A	19,0	14,0	M16	54	29	50.24.104	50xDIN 69872-MK4	28,0	21,0	M16	144	34
							50.24.105	50xDIN 69872-MK5	28,0	21,0	M20	144	34

Anzugsbolzen ISO 7388 Retention knobs ISO 7388

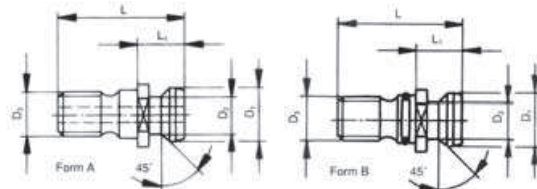

Art.-Nr.	Typ	D1	D2	D3	L	L1	Art.-Nr.	Typ	D1	D2	D3	L	L1
40.16.12	40xISO 7388-A	18,9	12,9	M16	44,5	16,4	40.16.122	40xISO 7388-MK2	18,9	12,9	M10	91	16,4
50.24.12	50xISO 7388-A	29,1	19,6	M24	65,5	25,5	40.16.123	40xISO 7388-MK3	18,9	12,9	M12	94	16,4
							40.16.124	40xISO 7388-MK4	18,9	12,9	M16	104	16,4
40.16.13	40xISO 7388-B	18,9	12,9	M16	44,5	16,4	50.24.122	50xISO 7388-MK2	29,1	19,6	M10	145	25,5
50.24.13	50xISO 7388-B	29,1	19,6	M24	65,5	25,5	50.24.123	50xISO 7388-MK3	29,1	19,6	M12	135	25,5
							50.24.124	50xISO 7388-MK4	29,1	19,6	M16	135	25,5
							50.24.125	50xISO 7388-MK5	29,1	19,6	M20	135	25,5

Anzugsbolzen MAS BT45°/60°/90° Retention knobs MAS BT45°/60°/90°

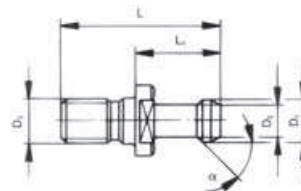

Art.-Nr.	Typ	D1	D2	D3	L	L1	Art.-Nr.	Typ	D1	D2	D3	L	L1
30.12.4	BT30x45°	11,0	7,0	M12	43	23	40.16.402	BT40x45°-MK2	15,0	10,0	M10	110	35
30.12.41	BT30x60°	11,0	7,0	M12	43	23	40.16.403	BT40x45°-MK3	15,0	10,0	M12	113	35
40.16.4	BT40x45°	15,0	10,0	M16	60	35	40.16.404	BT40x45°-MK4	15,0	10,0	M16	125	35
40.16.41	BT40x60°	15,0	10,0	M16	60	35	40.16.412	BT40x60°-MK2	15,0	10,0	M10	110	35
40.16.42	BT40x90°	15,0	10,0	M16	60	35	40.16.413	BT40x60°-MK3	15,0	10,0	M12	113	35
50.24.4	BT50x45°	23,0	17,0	M24	85	45	40.16.414	BT40x60°-MK4	15,0	10,0	M16	125	35
50.24.41	BT50x60°	23,0	17,0	M24	85	45	50.24.402	BT50x45°-MK2	23,0	17,0	M10	165	45
50.24.42	BT50x90°	23,0	17,0	M24	85	45	50.24.403	BT50x45°-MK3	23,0	17,0	M12	155	45
40.16.4-C	BT40x45° i.K.	15,0	10,0	M16	60	35	50.24.404	BT50x45°-MK4	23,0	17,0	M16	155	45
50.24.4-C	BT50x45° i.K.	23,0	17,0	M24	85	45	50.24.405	BT50x45°-MK5	23,0	17,0	M20	155	45

Werkzeugaufnahmen mit Holschaftkegel DIN 69893

Toolholders with HSK-taper shank
DIN 69893

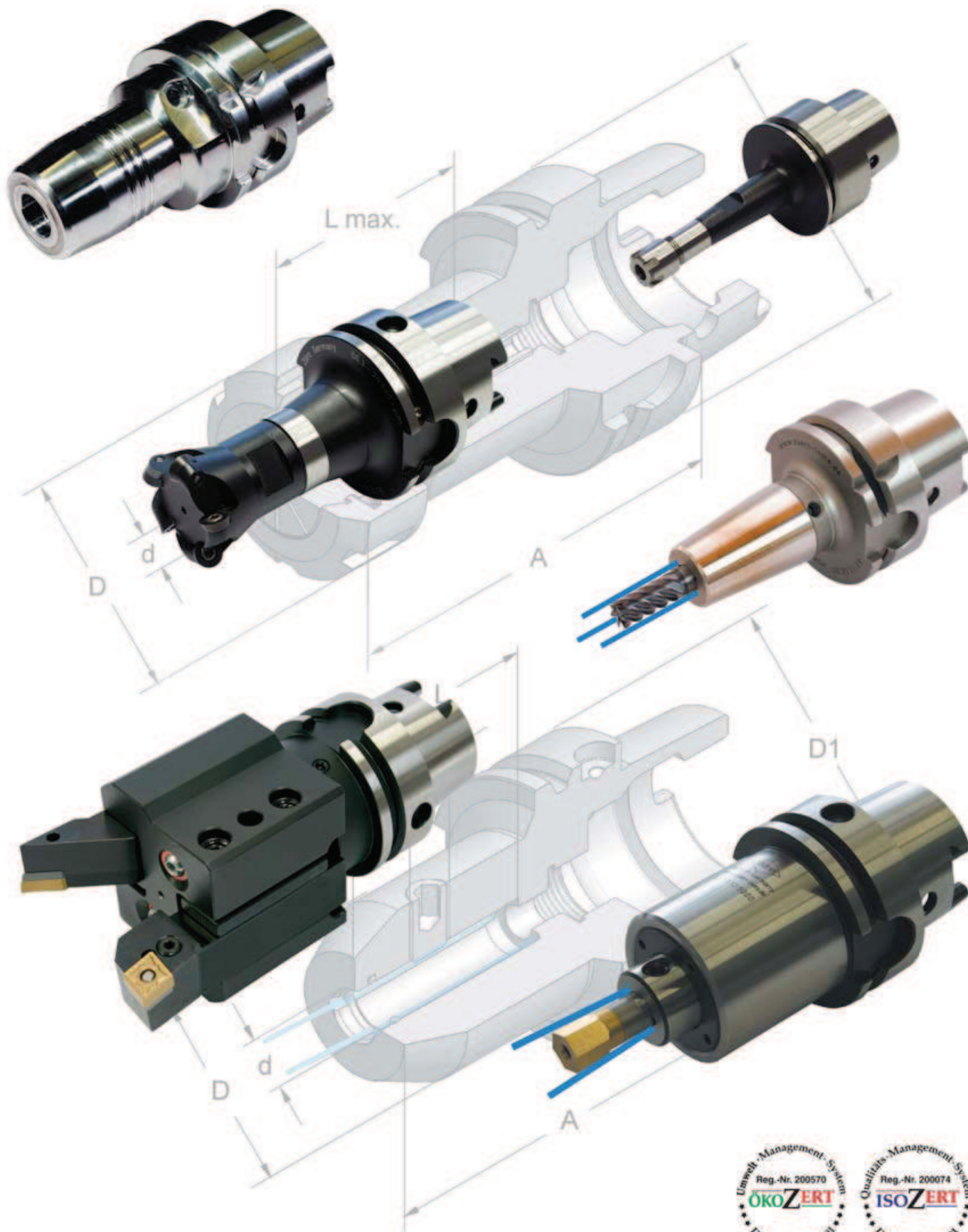

ZÜRN spannt + kühlt besser
ZÜRN clamps perfect with a better cooling effect

HSK E40



HSK 50 Schleifscheibenaufnahme
HSK 50 Grinding adapter



HSK 50 Spindel
HSK 50 Spindle



BT 40 x ER11 x 200



HSK A63 Bohrstangenhalter
HSK A63 Boring bar holder



SK 40 DIN 69871



HSK A63 Ausdrehkopf System Zürn
HSK A63 Boring head System Zürn



BT 30

Spannzangenfutter ohne Mitnehmernuten
Collet chuck without slots for driver

Werkzeugaufnahmen mit Holschaftkegel DIN 69893 Unterscheidungsmerkmale der verschiedenen Formen

Toolholders with HSK-tapers shank DIN 69893 Distinctive features of the different forms

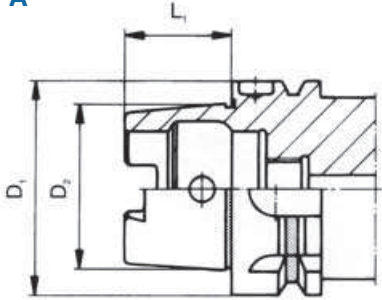
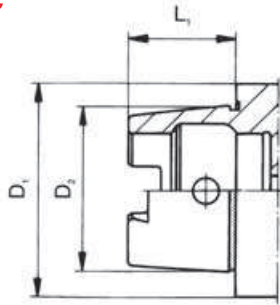
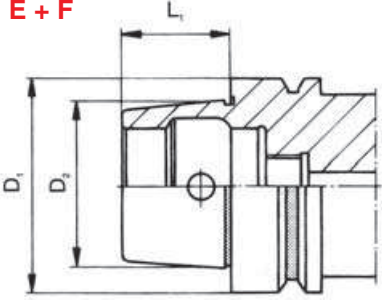
<p>Bevorzugte Ausführung für Bearbeitungszentren!</p> <ul style="list-style-type: none"> • Automatischer Werkzeugwechsel • Mitnehmernuten am Kegelsende • Kühlmittelzufuhr zentral durch den Automatikspanner mittels Kühlmittelrohr <p>Preferred type for machining centres!</p> <ul style="list-style-type: none"> • Automatic tool change • Driving slots at cone end • Central coolant supply through the automatic clamping part by means of coolant tubes 	<p>Form A</p> 
<p>Wie Form A, jedoch für manuellen Werkzeugwechsel!</p> <ul style="list-style-type: none"> • Kühlmittelzufuhr zentral durch den Spanner, dichtet ohne Kühlmittelrohr ab <p>As form A, but with manual tool change!</p> <ul style="list-style-type: none"> • Central coolant supply through the clamping part. Is sealing without coolant tubes 	<p>Form C</p> 
<p>Wie Form A, jedoch absolut rotationssymmetrisch!</p> <ul style="list-style-type: none"> • Ohne jegliche Mitnehmernuten für Hochgeschwindigkeitsbearbeitung geeignet <p>As form A, but balanced!</p> <ul style="list-style-type: none"> • Without any driving slots. Destinated for high speed machining 	<p>Form E + F</p> 

HSK Form A / C + E + F

Bunddurchmesser = Nenngroße D1 Collar dia D1	Kegeldurchmesser D2 Taper dia D2	Schaftlänge L1 Shank length L1
25	19	13
32	24	16
40	30	20
50	38	25
63	48	32
80	60	40
100	75	50
125	95	63
160	120	80
Form F 63	38	25

Spannzangenfutter für Spannzangen ER/ESX DIN 6499
Collet chuck for collets ER/ESX DIN 6499

Rundlaufgenauigkeit HSK zu Werkzeugaufnahme < 0,005
 Concentricity from the taper to the holding part < 0,005

gewuchtet G 6,3 - 20.000 U/min.
 balanced G 6,3 - 20.000 r.p.m.

Spannzangenfutter lieferbar mit Spannmutter ETS
 Collet chuck delivery with nuts ETS

Sonderausführungen auf Anfrage
 Special executions on inquiry

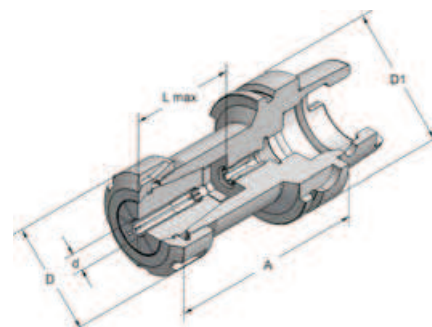

HSK - A 40							HSK - A 63						
Art.-Nr.	Typ	D1	A	d	D	L	Art.-Nr.	Typ	D1	A	d	D	L
40.11.07.2	HSK-A40xER11x 70	40	70	1- 7 424E	19	36	63.11.07.2	HSK-A63xER11x100	63	100	1- 7 424E	19	37
40.11.10.20	HSK-A40xER16x 60	40	60	1-10 426E	28	33							
40.11.10.2	HSK-A40xER16x 70	40	70	1-10 426E	28	37	63.11.10.20	HSK-A63xER16x 70	63	70	1-10 426E	28	34
40.11.13.2	HSK-A40xER20x 70	40	70	1-13 428E	34	39	63.11.10.2	HSK-A63xER16x100	63	100	1-10 426E	28	52
40.11.16.2	HSK-A40xER25x 70	40	70	1-16 430E	42	42	63.11.10.23	HSK-A63xER16x160	63	160	1-10 426E	28	52
40.11.20.2	HSK-A40xER32x 80	40	80	2-20 470E	50	47							
HSK - E 40							63.11.13.2	HSK-A63xER20x100	63	100	1-13 428E	34	52
40.12.07.2	HSK-E40xER11x 70	40	70	1- 7 424E	19	37							
40.12.07.22	HSK-E40xER11x100	40	70	1- 7 424E	19	37	63.11.16.20	HSK-A63xER25x 80	63	80	1-16 430E	42	41
40.12.10.20	HSK-E40xER16x 50	40	50	1-10 426E	28	33	63.11.16.2	HSK-A63xER25x100	63	100	1-16 430E	42	51
40.12.10.2	HSK-E40xER16x 70	40	70	1-10 426E	28	37	63.11.16.23	HSK-A63xER25x160	63	160	1-16 430E	42	65
40.12.16.20	HSK-E40xER25x 50	40	50	1-16 430E	42	41	63.11.16.25	HSK-A63xER25x200	63	200	1-16 430E	42	65
40.12.16.2	HSK-E40xER25x 70	40	70	1-16 430E	42	42							
40.12.20.2	HSK-E40xER32x 70	40	70	2-20 470E	50	47	63.11.20.20	HSK-A63xER32x 70	63	70	2-20 470E	50	46
HSK - C 40							63.11.20.2	HSK-A63xER32x100	63	100	2-20 470E	50	56
40.14.10.2	HSK-C40xER16x 60	40	60	1-10 426E	28	35	63.11.20.23	HSK-A63xER32x160	63	160	2-20 470E	50	57
40.14.16.2	HSK-C40xER25x 60	40	60	1-16 430E	42	41	63.11.20.25	HSK-A63xER32x200	63	200	2-20 470E	50	57
HSK - A 50													
50.11.10.2	HSK-A50xER16x100	50	100	1-10 426E	28	52	63.11.26.20	HSK-A63xER40x 80	63	80	3-30 472E	63	54
50.11.16.2	HSK-A50xER25x 80	50	80	1-16 430E	42	52	63.11.26.2	HSK-A63xER40x120	63	120	3-30 472E	63	70
50.11.20.2	HSK-A50xER32x100	50	100	2-20 470E	50	52	63.11.26.23	HSK-A63xER40x160	63	160	3-30 472E	63	70
HSK - E 50							HSK - E 63						
50.12.07.2	HSK-E50xER11x 80	50	80	1- 7 424E	19	37	63.12.10.2	HSK-E63xER16x100	63	100	1-10 426E	28	55
50.12.10.2	HSK-E50xER16x100	50	100	1-10 426E	28	52	63.12.16.2	HSK-E63xER25x100	63	100	1-16 430E	42	55
50.12.16.2	HSK-E50xER25x 80	50	80	1-16 430E	42	46	63.12.20.2	HSK-E63xER32x100	63	100	2-20 470E	50	55
50.12.20.2	HSK-E50xER32x100	50	100	2-20 470E	50	57	63.12.26.2	HSK-E63xER40x100	63	100	3-30 472E	63	55
HSK - C 50							HSK - F 63						
50.14.10.2	HSK-C50xER16x 70	50	70	1-10 426E	28	37	63.13.10.2	HSK-F63xER16x 76	63	76	1-10 426E	28	47
50.14.16.2	HSK-C50xER25x 70	50	70	1-16 430E	42	42	63.13.16.2	HSK-F63xER25x 76	63	76	1-16 430E	42	47
50.14.20.2	HSK-C50xER32x 70	50	70	2-20 470E	50	47	63.13.20.2	HSK-F63xER32x 76	63	76	2-20 470E	50	54
							63.13.26.2	HSK-F63xER40x 76	63	76	3-30 472E	63	54
HSK - A 100							HSK - A 100						
100.11.10.2	HSK-A100xER16x100	100	100	1-10 426E	28	40	100.11.20.2	HSK-A100xER32x100	100	100	2-20 470E	50	35
100.11.10.23	HSK-A100xER16x160	100	160	1-10 426E	28	42	100.11.20.23	HSK-A100xER32x160	100	160	2-20 470E	50	52
100.11.10.25	HSK-A100xER16x200	100	200	1-10 426E	28	42	100.11.20.25	HSK-A100xER32x200	100	200	2-20 470E	50	52
100.11.16.2	HSK-A100xER25x100	100	100	1-16 430E	42	40	100.11.26.2	HSK-A100xER40x120	100	120	3-30 472E	63	50
100.11.16.23	HSK-A100xER25x160	100	160	1-16 430E	42	50	100.11.26.23	HSK-A100xER40x160	100	160	3-30 472E	63	50
100.11.16.25	HSK-A100xER25x200	100	200	1-16 430E	42	50	100.11.26.25	HSK-A100xER40x200	100	200	3-30 472E	63	50

Spannzangenfutter für Spannzangen DIN 6388
Collet chuck for collets DIN 6388

Rundlaufgenauigkeit HSK zu Werkzeugaufnahme < 0,005
 Concentricity from the taper to the holding part < 0,005

gewuchtet G 6,3 - 20.000 U/min.
 balanced G 6,3 - 20.000 r.p.m.

Spannzangenfutter lieferbar mit Spannmutter ETS
 Collet chuck delivery with nuts ETS

Sonderausführungen auf Anfrage
 Special executions on inquiry

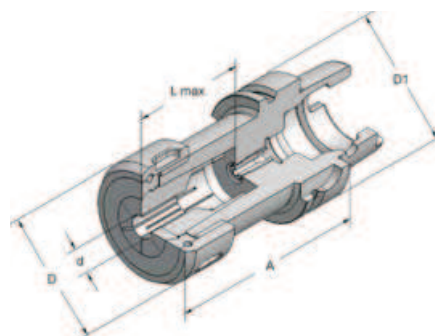

HSK - A 50							HSK - A 63						
Art.-Nr.	Typ	D1	A	d	D	L	Art.-Nr.	Typ	D1	A	d	D	L
50.11.16.1	HSK-A50x2-16x100	50	100	2-16	415E	43 62	63.11.25.1	HSK-A63x2-25x100	63	100	2-25	462E	60 64
							HSK - F 63						
							63.13.25.1	HSK-F63x2-25x	76	63	76	2-25	462E 60 58
							63.13.25.12	HSK-F63x2-25x100	63	100	2-25	462E	60 58
							HSK - A 100						
							100.11.32.1	HSK-A-100x3-32x130	100	130	3-32	467E	72 90

CNC-Bohrfutter für Rechts- und Linkslauf
CNC-Drill chucks for clockwise and anti-clockwise rotation

Rundlaufgenauigkeit HSK zu Werkzeugaufnahme < 0,04
 Concentricity from the taper to the holding part < 0,04

gewuchtet G 6,3 - 8.000 U/min.
 balanced G 6,3 - 8.000 r.p.m.

Typ K mit innerer Kühlmittelzufuhr, komplett mit Kühlmittelübergaberohr
 Type K with internal coolant, complete with connection for coolant tube

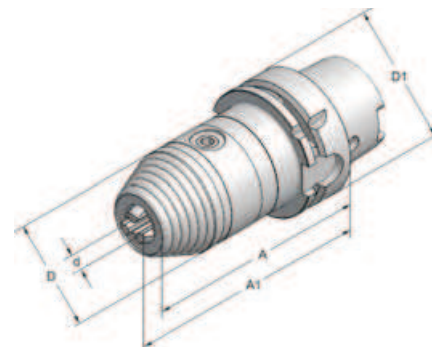

HSK - A 40							HSK - A 63						
Art.-Nr.	Typ	D1	A	A1	d	D	Art.-Nr.	Typ	D1	A	A1	d	D
40.11.08	HSK-A40x1- 8x 83	40	83	86	1- 8	36	63.11.08	HSK-A63x1- 8x 83	63	83	86	1- 8	36
HSK - A50													
50.11.13	HSK-A50x1-13x108	50	108	118	1-13	50	63.11.13	HSK-A63x1-13x103	63	103	113	1-13	50
HSK - E 50													
50.12.08	HSK-E50x1- 8x 77	50	77	80	1- 8	50	63.11.16	HSK-A63x3-16x103	63	103	115	3-16	57
50.12.13	HSK-E50x1-13x108	50	108	118	1-13	50	63.11.13k	HSK-A63x1-13x103	63	103	113	1-13	50
							63.11.16k	HSK-A63x3-16x103	63	103	115	3-16	57
							HSK - E 63						
							63.12.13	HSK-E63x1-13x103	63	103	113	1-13	50
							HSK - F 63						
							63.13.13	HSK-F63x1-13x103	63	103	113	1-13	50
							HSK - A 100						
							100.11.13k	HSK-A100x1-13x111	100	111	121	1-13	50
							100.11.16k	HSK-A100x3-16x111	100	111	123	3-16	57

Kombiaufsteckfräsdorn DIN 6358

Universal arbor DIN 6358

Rundlaufgenauigkeit HSK zu Werkzeugaufnahme < 0,005
 Concentricity from the taper to the holding part < 0,005

gewuchtet G 6,3 - 8.000 U/min.
 balanced G 6,3 - 8.000 r.p.m.

HSK-A63 mit innerer Kühlmittelzufuhr für Werkzeuge mit Kühlkanal zur Schneide
 HSK-A63 with internal coolant supply for tools with coolant channel to the cutting edge

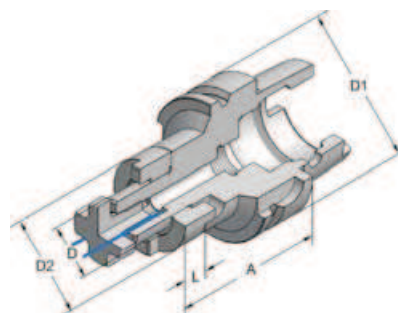

HSK - A 63

Art.-Nr.	Typ	D1	A	D	D2	L
63.11.16.4	HSK-A63x16x 60	63	60	16	32	10
63.11.16.42	HSK-A63x16x100	63	100	16	32	10
63.11.16.43	HSK-A63x16x160	63	160	16	32	10
63.11.22.4	HSK-A63x22x 60	63	60	22	40	12
63.11.22.42	HSK-A63x22x100	63	100	22	40	12
63.11.22.43	HSK-A63x22x160	63	160	22	40	12

HSK - A 63

Art.-Nr.	Typ	D1	A	D	D2	L
63.11.27.4	HSK-A63x27x 60	63	60	27	48	12
63.11.27.42	HSK-A63x27x100	63	100	27	48	12
63.11.27.43	HSK-A63x27x160	63	160	27	48	12
63.11.32.4	HSK-A63x32x 60	63	60	32	58	14
63.11.32.42	HSK-A63x32x100	63	100	32	58	14
63.11.40.4	HSK-A63x40x 70	63	70	40	70	14

HSK - A 100

100.11.16.42	HSK-A100x16x100	100	100	16	32	10
100.11.16.43	HSK-A100x16x160	100	160	16	32	10
100.11.22.42	HSK-A100x22x100	100	100	22	40	12
100.11.22.43	HSK-A100x22x160	100	160	22	40	12

HSK - A 100

100.11.27.42	HSK-A100x27x100	100	100	27	48	12
100.11.27.43	HSK-A100x27x160	100	160	27	48	12
100.11.32.42	HSK-A100x32x100	100	100	32	58	14
100.11.40.42	HSK-A100x40x100	100	100	40	70	14

Kegelhülse MK DIN 228 Form A + B

Reducing adapter MT DIN 228 form A + B

Rundlaufgenauigkeit HSK zu Werkzeugaufnahme < 0,005
 Concentricity from the taper to the holding part < 0,005

gewuchtet G 6,3 - 8.000 U/min.
 balanced G 6,3 - 8.000 r.p.m.

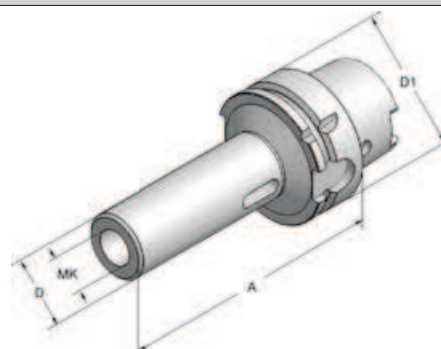

HSK - A 63

Art.-Nr.	Typ	D1	A	MK	D
63.11.01.5	HSK-A63xMK1x100	63	100	1	25
63.11.02.5	HSK-A63xMK2x120	63	120	2	32
63.11.03.5	HSK-A63xMK3x140	63	140	3	40
63.11.04.5	HSK-A63xMK4x160	63	160	4	48
63.11.01.55	HSK-A63xMK1x100	63	100	1	25
63.11.02.55	HSK-A63xMK2x120	63	120	2	32
63.11.03.55	HSK-A63xMK3x140	63	140	3	40
63.11.04.55	HSK-A63xMK4x165	63	165	4	48

DIN 6384 mit Anzugsgewinde .55
 DIN 6384 with retention thread .55

Messerkopfaufnahme DIN 6357
Shell mill adapter for facing cutters DIN 6357

Rundlaufgenauigkeit HSK zu Werkzeugaufnahme < 0,005
 Concentricity from the taper to the holding part < 0,005

gewuchtet G 6,3 - 8.000 U/min.
 balanced G 6,3 - 8.000 r.p.m.

HSK-A + E mit innerer Kühlmittelzufuhr für Werkzeuge mit Kühlkanal zur Schneide
 HSK-A63 with internal coolant supply for tools with coolant channel to the cutting edge

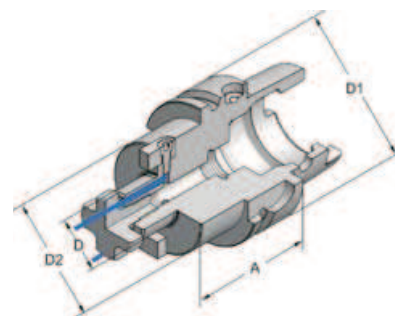

HSK - A 40						HSK - A 63					
Art.-Nr.	Typ	D1	A	D	D2	Art.-Nr.	Typ	D1	A	D	D2
40.11.16.9	HSK-A40x16x50	40	50	16	38	63.11.16.9	HSK-A63x16x 50	63	50	16	39
40.11.22.9	HSK-A40x22x50	40	50	22	44	63.11.16.92	HSK-A63x16x100	63	100	16	39
40.11.27.9	HSK-A40x27x50	40	50	27	55	63.11.22.9	HSK-A63x22x 50	63	50	22	49
HSK - E 40						63.11.22.92	HSK-A63x22x100	63	100	22	49
40.12.16.9	HSK-E40x16x50	40	50	16	38	63.11.27.9	HSK-A63x27x 60	63	60	27	60
40.12.22.9	HSK-E40x22x50	40	50	22	44	63.11.27.92	HSK-A63x27x100	63	100	27	60
HSK - A 50						63.11.32.9	HSK-A63x32x 60	63	60	32	68
50.11.16.9	HSK-A50x16x50	50	50	16	39	63.11.32.92	HSK-A63x32x100	63	100	32	68
50.11.22.9	HSK-A50x22x50	50	50	22	42	63.11.40.9	HSK-A63x40x 60	63	60	40	88
50.11.27.9	HSK-A50x27x55	50	55	27	60	HSK - E 63					
HSK - E 50						63.12.16.9	HSK-E63x16x 50	63	50	16	39
50.12.16.9	HSK-E50x16x50	50	50	16	39	63.12.22.9	HSK-E63x22x 50	63	50	22	49
50.12.22.9	HSK-E50x22x50	50	50	22	42	63.12.27.9	HSK-E63x27x 50	63	60	27	60
50.12.27.9	HSK-E50x27x55	50	55	27	60	63.12.32.9	HSK-E63x32x 50	63	60	32	68
						HSK - F 63					
						63.13.16.9	HSK-F63x16x 50	63	50	16	39
						63.13.22.9	HSK-F63x22x 50	63	50	22	49
						63.13.27.9	HSK-F63x27x 50	63	60	27	60
						63.13.32.9	HSK-F63x32x 50	63	60	32	68
HSK - A 100						HSK - A 100					
100.11.22.92	HSK-A100x22x100	100	100	22	49	100.11.32.92	HSK-A100x32x100	100	100	27	68
100.11.22.93	HSK-A100x22x160	100	160	22	49	100.11.32.93	HSK-A100x32x160	100	160	27	68
100.11.27.92	HSK-A100x27x100	100	100	27	60	100.11.40.9	HSK-A100x40x 60	100	60	32	88
100.11.27.93	HSK-A100x27x160	100	160	27	60	100.11.40.92	HSK-A100x40x100	100	100	40	88

Zylinderschaftaufnahme Whistle-Notch DIN 1835 E
Holder for straight shank tools Whistle-Notch DIN 1835 E

Rundlaufgenauigkeit HSK zu Werkzeugaufnahme < 0,005
 Concentricity from the taper to the holding part < 0,005

gewuchtet G 6,3 - 20.000 U/min.
 balanced G 6,3 - 20.000 r.p.m.

Sonderausführungen auf Anfrage
 Special executions on inquiry

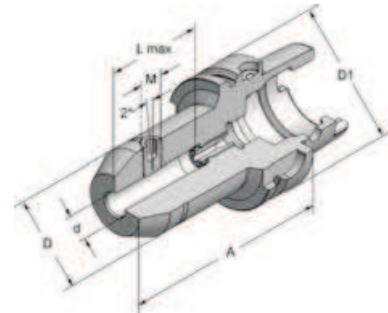

HSK - A 40									HSK - A 63								
Art.-Nr.	Typ	D1	A	d	D	M	L		Art.-Nr.	Typ	D1	A	d	D	M	L	
40.11.06.65	HSK-A40x06Ex 60	40	60	6	25	6	36		63.11.06.65	HSK-A63x06Ex 80	63	80	6	25	6	40	
40.11.08.65	HSK-A40x08Ex 60	40	60	8	28	8	36		63.11.06.652	HSK-A63x06Ex130	63	130	6	25	6	40	
40.11.10.65	HSK-A40x10Ex 60	40	60	10	35	10	40		63.11.08.65	HSK-A63x08Ex 80	63	80	8	28	8	40	
40.11.12.65	HSK-A40x12Ex 70	40	70	12	42	12	45		63.11.08.652	HSK-A63x08Ex130	63	130	8	28	8	40	
40.11.14.65	HSK-A40x14Ex 70	40	70	14	44	12	45		63.11.10.65	HSK-A63x10Ex 80	63	80	10	35	10	45	
40.11.16.65	HSK-A40x16Ex 70	40	70	16	48	14	48		63.11.10.652	HSK-A63x10Ex130	63	130	10	35	10	45	
HSK - A 50									HSK - A 63								
50.11.06.65	HSK-A50x06Ex 80	50	80	6	25	6	36		63.11.12.65	HSK-A63x12Ex 90	63	90	12	42	12	52	
50.11.08.65	HSK-A50x08Ex 80	50	80	8	28	8	36		63.11.12.652	HSK-A63x12Ex130	63	130	12	42	12	52	
50.11.10.65	HSK-A50x10Ex 80	50	80	10	35	10	40		63.11.14.65	HSK-A63x14Ex 90	63	90	14	44	12	52	
50.11.12.65	HSK-A50x12Ex 90	50	90	12	42	12	45		63.11.14.652	HSK-A63x14Ex130	63	130	14	44	12	52	
50.11.14.65	HSK-A50x14Ex 90	50	90	14	44	12	45		63.11.16.65	HSK-A63x16Ex100	63	100	16	48	14	55	
50.11.16.65	HSK-A50x16Ex 90	50	90	16	48	14	48		63.11.16.652	HSK-A63x16Ex130	63	130	16	48	14	55	
50.11.20.65	HSK-A50x20Ex100	50	100	20	50	16	52		63.11.18.65	HSK-A63x18Ex100	63	100	18	50	14	55	
									63.11.20.65	HSK-A63x20Ex100	63	100	20	52	16	59	
									63.11.20.652	HSK-A63x20Ex130	63	130	20	52	16	59	
									63.11.25.65	HSK-A63x25Ex110	63	110	25	63	18x2	67	
									63.11.32.65	HSK-A63x32Ex110	63	110	32	72	20x2	68	
HSK - A 100									HSK - A 100								
100.11.06.65	HSK-A100x06Ex100	100	100	6	25	6	40		100.11.14.65	HSK-A100x14Ex100	100	100	14	44	12	55	
100.11.06.652	HSK-A100x06Ex160	100	160	6	25	6	40		100.11.14.652	HSK-A100x14Ex160	100	160	14	44	12	55	
100.11.08.65	HSK-A100x08Ex100	100	100	8	28	8	40		100.11.16.65	HSK-A100x16Ex100	100	100	16	48	14	55	
100.11.08.652	HSK-A100x08Ex160	100	160	8	28	8	40		100.11.16.652	HSK-A100x16Ex160	100	160	16	48	14	59	
100.11.10.65	HSK-A100x10Ex100	100	100	10	35	10	45		100.11.20.65	HSK-A100x20Ex110	100	110	20	52	16	55	
100.11.10.652	HSK-A100x10Ex160	100	160	10	35	10	45		100.11.20.652	HSK-A100x20Ex160	100	160	20	52	16	55	
100.11.12.65	HSK-A100x12Ex100	100	100	12	42	12	52		100.11.25.65	HSK-A100x25Ex120	100	120	25	63	18x2	55	
100.11.12.652	HSK-A100x12Ex160	100	160	12	42	12	52		100.11.32.65	HSK-A100x32Ex120	100	120	32	72	20x2	59	

Zylinderschaftaufnahme Weldon DIN 1835 B

Holder for straight shank tools weldon DIN 1835 B

Rundlaufgenauigkeit HSK zu Werkzeugaufnahme < 0,005
 Concentricity from the taper to the holding part < 0,005

gewuchtet G 6,3 - 20.000 U/min.
 balanced G 6,3 - 20.000 r.p.m.

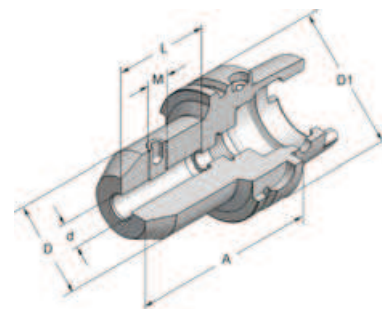

HSK - E 40

Typ A

HSK - A 63

Art.-Nr.	Typ	D1	A	d	D	M	L	Art.-Nr.	Typ	D1	A	d	D	M	L
40.12.06.6	HSK-E40x06x60	40	60	6	25	6	38	63.11.06.6	HSK-A63x06x65	63	63	6	25	6	38
40.12.08.6	HSK-E40x08x60	40	60	8	28	8	38	63.11.06.62	HSK-A63x06x120	63	120	6	25	6	38
40.12.10.6	HSK-E40x10x60	40	60	10	35	10	42	63.11.06.63	HSK-A63x06x160	63	160	6	25	6	38
40.12.12.6	HSK-E40x12x70	40	70	12	42	12	48	63.11.08.6	HSK-A63x08x65	63	63	8	28	8	38
40.12.16.6	HSK-E40x16x70	40	70	16	44	14	55	63.11.08.62	HSK-A63x08x120	63	120	8	28	8	38
40.12.20.6	HSK-E40x20x70	40	70	20	44	16	55	63.11.08.63	HSK-A63x08x160	63	160	8	28	8	38
	HSK - E 50							63.11.10.6	HSK-A63x10x65	63	63	10	35	10	42
50.12.06.6	HSK-E50x06x65	50	65	6	25	6	38	63.11.10.62	HSK-A63x10x120	63	120	10	35	10	42
50.12.08.6	HSK-E50x08x65	50	65	8	28	8	38	63.11.10.63	HSK-A63x10x160	63	160	10	35	10	42
50.12.10.6	HSK-E50x10x65	50	65	10	35	10	42	63.11.12.6	HSK-A63x12x80	63	80	12	42	12	48
50.12.12.6	HSK-E50x12x80	50	80	12	42	12	48	63.11.12.62	HSK-A63x12x120	63	120	12	42	12	48
50.12.16.6	HSK-E50x16x80	50	80	16	48	14	55	63.11.12.63	HSK-A63x12x160	63	160	12	42	12	48
50.12.20.6	HSK-E50x20x80	50	80	20	49	16	55	63.11.14.6	HSK-A63x14x80	63	80	14	44	12	48
	HSK - F 63							63.11.14.62	HSK-A63x14x120	63	120	14	44	12	48
63.13.06.6	HSK-F63x06x80	63	80	6	25	6	38	63.11.16.6	HSK-A63x16x80	63	80	16	48	14	55
63.13.08.6	HSK-F63x08x80	63	80	8	28	8	38	63.11.16.62	HSK-A63x16x120	63	120	16	48	14	55
63.13.10.6	HSK-F63x10x80	63	80	10	35	10	42	63.11.16.63	HSK-A63x16x160	63	160	16	48	14	55
63.13.12.6	HSK-F63x12x80	63	80	12	42	12	48	63.11.18.6	HSK-A63x18x80	63	80	18	50	14	55
63.13.14.6	HSK-F63x14x80	63	80	14	44	12	48	63.11.18.62	HSK-A63x18x120	63	120	18	50	14	55
63.13.16.6	HSK-F63x16x80	63	80	16	48	14	55	63.11.20.6	HSK-A63x20x80	63	80	20	52	16	55
63.13.18.6	HSK-F63x18x80	63	80	18	50	14	55	63.11.20.62	HSK-A63x20x120	63	120	20	52	16	55
63.13.20.6	HSK-F63x20x80	63	80	20	52	16	55	63.11.20.63	HSK-A63x20x160	63	160	20	52	16	55
63.13.25.6	HSK-F63x25x80	63	80	25	63	18x2	65	63.11.25.6	HSK-A63x25x110	63	110	25	63	18x2	65
63.13.32.6	HSK-F63x32x80	63	80	32	72	20x2	65	63.11.25.63	HSK-A63x25x160	63	160	25	63	18x2	65
								63.11.32.6	HSK-A63x32x110	63	110	32	72	20x2	65
								63.11.40.6	HSK-A63x40x120	63	120	40	64	16x1	75



HSK - A 63 INCH

63.11.100	HSK-A63x1/4"x65	63	63	65	1/4"	25	6	38
63.11.101	HSK-A63x3/8"x65	63	63	65	3/8"	35	10	42
63.11.102	HSK-A63x1/2"x80	63	63	80	1/2"	42	12	48
63.11.103	HSK-A63x5/8"x80	63	63	80	5/8"	48	14	55
63.11.104	HSK-A63x3/4"x80	63	63	80	3/4"	52	16	55
63.11.105	HSK-A63x1" x110	63	110	1"	63	18x2	65	
63.11.106	HSK-A63x1 1/4"x110	63	110	1 1/4"	72	20x2	65	

Zylinderschaftaufnahme Weldon DIN 1835 B mit Kühlkanal

Holder for straight shank tools weldon DIN 1835 B with through coolant channel

Rundlaufgenauigkeit HSK zu Werkzeugaufnahme < 0,005
 Concentricity from the taper to the holding part < 0,005

gewuchtet G 6,3 - 20.000 U/min.
 balanced G 6,3 - 20.000 r.p.m.

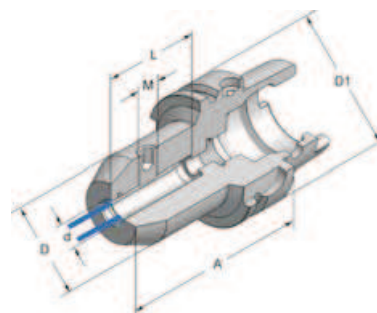

Für Werkzeuge mit i.K. muss O-Ring eingesetzt werden
 O-Ring muss separat bestellt werden
 For tools with through coolant a sealing ring must be used
 Sealing ring has to be ordered separately



HSK - A 40

HSK - A 63

Art.-Nr.	Typ	D1	A	d	D	M	L	Art.-Nr.	Typ	D1	A	d	D	M	L	
40.11.06.66	HSK-A 40x06x 60	40	60	6	25	6	38	63.11.06.66	HSK-A63x06x 65	63	65	6	25	6	38	
40.11.08.66	HSK-A 40x08x 60	40	60	8	28	8	38	63.11.06.662	HSK-A63x06x100	63	100	6	25	6	38	
40.11.10.66	HSK-A 40x10x 60	40	60	10	35	10	42	63.11.06.663	HSK-A63x06x160	63	160	6	25	6	38	
40.11.12.66	HSK-A 40x12x 70	40	70	12	42	12	48	63.11.08.66	HSK-A63x08x 65	63	65	8	28	8	38	
40.11.16.66	HSK-A 40x16x 70	40	70	16	44	14	55	63.11.08.662	HSK-A63x08x100	63	100	8	28	8	38	
40.11.20.66	HSK-A 40x20x 70	40	70	20	44	16	55	63.11.08.663	HSK-A63x08x160	63	160	8	28	8	38	
HSK - A 50								HSK - A 63								
50.11.06.66	HSK-A 50x06x 65	50	65	6	25	6	38	63.11.10.66	HSK-A63x10x 65	63	65	10	35	10	42	
50.11.08.66	HSK-A 50x08x 65	50	65	8	28	8	38	63.11.10.662	HSK-A63x10x100	63	100	10	35	10	42	
50.11.10.66	HSK-A 50x10x 65	50	65	10	35	10	42	63.11.10.663	HSK-A63x10x160	63	160	10	35	10	42	
50.11.12.66	HSK-A 50x12x 80	50	80	12	42	12	48	63.11.12.66	HSK-A63x12x 80	63	80	12	42	12	48	
50.11.12.66	HSK-A 50x12x 80	50	80	12	42	12	48	63.11.12.662	HSK-A63x12x100	63	100	12	42	12	48	
50.11.14.66	HSK-A 50x14x 80	50	80	14	44	12	48	63.11.12.663	HSK-A63x12x160	63	160	12	42	12	48	
50.11.16.66	HSK-A 50x16x 80	50	80	16	48	14	55	63.11.14.66	HSK-A63x14x 80	63	80	14	44	12	48	
50.11.18.66	HSK-A 50x18x 80	50	80	18	50	14	55	63.11.14.663	HSK-A63x14x160	63	160	14	44	12	48	
50.11.20.66	HSK-A 50x20x 80	50	80	20	52	16	55	63.11.16.66	HSK-A63x16x 80	63	80	16	48	14	55	
50.11.25.66	HSK-A 50x25x 80	50	80	25	52	16x1	65	63.11.16.662	HSK-A63x16x100	63	100	16	48	14	55	
50.11.32.66	HSK-A 50x32x 90	50	80	32	52	16x1	65	63.11.16.663	HSK-A63x16x160	63	160	16	48	14	55	
HSK - A 100								O-Ring Sealing ring								
100.11.06.66	HSK-A100x06x100	100	100	6	25	6	38	63.11.18.66	HSK-A63x18x 80	63	80	18	50	14	55	
100.11.06.663	HSK-A100x06x160	100	160	6	25	6	38	63.11.18.663	HSK-A63x18x160	63	160	18	50	14	55	
100.11.08.66	HSK-A100x08x100	100	100	8	28	8	38	63.11.20.66	HSK-A63x20x 80	63	80	20	52	16	55	
100.11.08.663	HSK-A100x08x160	100	160	8	28	8	38	63.11.20.662	HSK-A63x20x100	63	100	20	52	16	55	
100.11.10.66	HSK-A100x10x100	100	100	10	35	10	42	63.11.20.663	HSK-A63x20x160	63	160	20	52	16	55	
100.11.10.663	HSK-A100x10x160	100	160	10	35	10	42	63.11.25.66	HSK-A63x25x 90	63	90	25	63	18x2	65	
100.11.12.66	HSK-A100x12x100	100	100	12	42	12	48	63.11.32.66	HSK-A63x32x 90	63	90	32	63	20x2	65	
100.11.12.663	HSK-A100x12x160	100	160	12	42	12	48									
100.11.14.66	HSK-A100x14x100	100	100	14	44	12	48								Art.-Nr.	Typ
100.11.16.66	HSK-A100x16x100	100	100	16	48	14	55								270100	ø 6,0 x 1,5
100.11.16.663	HSK-A100x16x160	100	160	16	48	14	55								271100	ø 8,0 x 1,5
100.11.20.66	HSK-A100x20x100	100	100	20	52	16	55								272100	ø10,0 x 2,0
100.11.20.663	HSK-A100x20x160	100	160	20	52	16	55								273100	ø12,0 x 2,0
100.11.25.66	HSK-A100x25x100	100	100	25	63	18x2	65								274100	ø14,0 x 2,0
100.11.25.663	HSK-A100x25x160	100	160	25	63	18x2	65								275100	ø16,0 x 2,5
100.11.32.66	HSK-A100x32x100	100	100	32	72	20x2	65								276100	ø18,0 x 2,5
100.11.32.663	HSK-A100x32x160	100	160	32	72	20x2	65								277100	ø20,0 x 2,5
100.11.40.66	HSK-A100x40x100	100	100	40	80	20x2	75								278100	ø25,0 x 3,0
															279100	ø32,0 x 3,0
															299100	ø40,0 x 3,5

Schrumpffutter POWER-FLASH high-speed

Shrinking chuck POWER-FLASH high-speed

Kühlmittelzufuhr über Kühlkanäle in der Bohrung
 Konzentrierte Kühlmittelzufuhr bis 20.000 U/min zur Werkzeugschneide
 Coolant supply through coolant channels in the boring
 Concentrated coolant supply up to 20.000 r.p.m. to the cutting edge

gewuchtet G 2,5 - 20.000 U/min.
 balanced G 2,5 - 20.000 r.p.m.



HSK - E40
HSK - E50

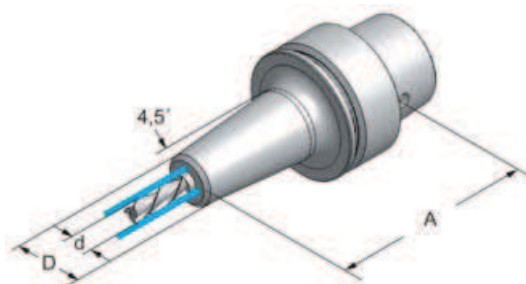

HSK - E40
ø3 - 12

HSK - E50
ø3 - 12

Art.-Nr.	Typ	A	d	D	ik	Art.-Nr.	Typ	A	d	D	ik
40.12.03.37	HSK-E40x03SCx65	65	3	10	2	50.12.03.37	HSK-E50x03SCx80	80	3	10	2
40.12.04.37	HSK-E40x04SCx65	65	4	11	2	50.12.04.37	HSK-E50x04SCx80	80	4	11	2
40.12.05.37	HSK-E40x05SCx65	65	5	14	2	50.12.05.37	HSK-E50x05SCx80	80	5	14	2
40.12.06.37	HSK-E40x06SCx65	65	6	21	3	50.12.06.37	HSK-E50x06SCx80	80	6	21	3
40.12.08.37	HSK-E40x08SCx65	65	8	21	3	50.12.08.37	HSK-E50x08SCx80	80	8	21	3
40.12.10.37	HSK-E40x10SCx65	65	10	24	3	50.12.10.37	HSK-E50x10SCx85	85	10	24	3
40.12.12.37	HSK-E40x12SCx70	70	12	24	3	50.12.12.37	HSK-E50x12SCx90	90	12	24	3

Weitere HSK-Ausführungen auf Anfrage
 Further HSK-executions on inquiry

Weitere HSK-Ausführungen auf Anfrage
 Further HSK-executions on inquiry

Schrumpffutter POWER-FLASH high-speed

Shrinking chuck POWER-FLASH high-speed

Kühlmittelezufuhr über Kühlkanäle in der Bohrung
 Konzentrierte Kühlmittelezufuhr bis 20.000 U/min zur Werkzeugschneide
 Coolant supply through coolant channels in the boring
 Concentrated coolant supply up to 20.000 r.p.m. to the cutting edge

gewuchtet G 6,3 - 20.000 U/min.
 balanced G 6,3 - 20.000 r.p.m.



HSK - A63

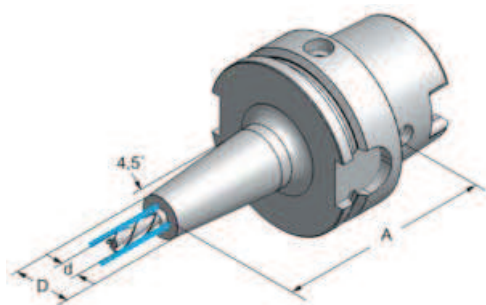

HSK - A63
 ø3 - 32

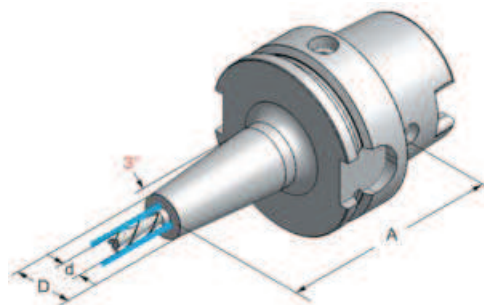

HSK - A63
 ø3 - 20

Schlanke Ausführung
 Slim execution

Art.-Nr.	Typ	A	d	D	ik	Art.-Nr.	Typ	A	d	D	ik
63.11.03.37	HSK-A63x03SCx 80	80	3	10	2	63.11.03.370	HSK-A63x03SCx80	80	3	9	2
63.11.04.37	HSK-A63x04SCx 80	80	4	11	2	63.11.04.370	HSK-A63x04SCx80	80	4	10	2
63.11.05.37	HSK-A63x05SCx 80	80	5	14	2	63.11.05.370	HSK-A63x05SCx80	80	5	11	2
63.11.06.37	HSK-A63x06SCx 80	80	6	21	3	63.11.06.370	HSK-A63x06SCx80	80	6	12	3
63.11.08.37	HSK-A63x08SCx 80	80	8	21	3	63.11.08.370	HSK-A63x08SCx80	80	8	14	3
63.11.10.37	HSK-A63x10SCx 85	85	10	24	3	63.11.10.370	HSK-A63x10SCx80	80	10	16	3
63.11.12.37	HSK-A63x12SCx 90	90	12	24	3	63.11.12.370	HSK-A63x12SCx80	80	12	18	3
63.11.16.37	HSK-A63x16SCx 85	95	16	26	3	63.11.14.370	HSK-A63x14SCx80	80	14	20	3
63.11.20.37	HSK-A63x20SCx100	100	20	33	3	63.11.16.370	HSK-A63x16SCx80	80	16	22	3
63.11.25.37	HSK-A63x25SCx100	100	25	44	3	63.11.20.370	HSK-A63x20SCx80	80	20	26	3
63.11.32.37	HSK-A63x32SCx100	100	32	44	3						

Schrumpffutter POWER-FLASH high-speed

Shrinking chuck POWER-FLASH high-speed

Kühlmittelzufuhr über Kühlkanäle in der Bohrung
 Konzentrierte Kühlmittelzufuhr bis 20.000 U/min zur Werkzeugschneide
 Coolant supply through coolant channels in the boring
 Concentrated coolant supply up to 20.000 r.p.m. to the cutting edge

gewuchtet G 6,3 - 20.000 U/min.
 balanced G 6,3 - 20.000 r.p.m.



HSK - A100

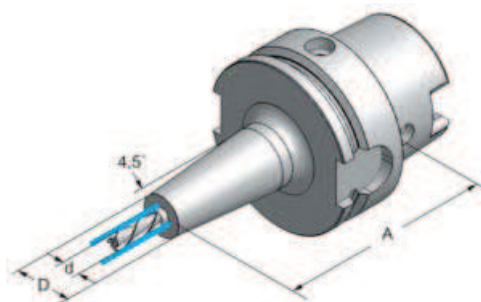

HSK - A100
ø6 - 12

HSK - A100
ø14 - 32

Art.-Nr.	Typ	A	d	D	ik	Art.-Nr.	Typ	A	d	D	ik
100.11.06.37	HSK-A100x06SCx100	100	6	21	3	100.11.14.37	HSK-A100x14SCx100	100	14	27	3
100.11.06.373	HSK-A100x06SCx160	160	6	21	3	100.11.16.37	HSK-A100x16SCx100	100	16	27	3
100.11.08.37	HSK-A100x08SCx100	100	8	21	3	100.11.16.373	HSK-A100x16SCx160	160	16	27	3
100.11.08.373	HSK-A100x08SCx160	160	8	21	3	100.11.20.37	HSK-A100x20SCx100	100	20	33	3
100.11.10.37	HSK-A100x10SCx100	100	10	24	3	100.11.20.373	HSK-A100x20SCx160	160	20	33	3
100.11.10.373	HSK-A100x10SCx160	160	10	24	3	100.11.25.37	HSK-A100x25SCx120	120	25	44	3
100.11.12.37	HSK-A100x12SCx100	100	12	24	3	100.11.25.373	HSK-A100x25SCx160	160	25	44	3
100.11.12.373	HSK-A100x12SCx160	160	12	24	3	100.11.32.37	HSK-A100x32SCx120	120	32	44	3

POWER-FLASH Werkzeugaufnahmen

Kühlmittelezufuhr intern und extern direkt zur Werkzeugschneide

POWER-FLASH Toolholders

Internal and external coolant supply directly to the cutting edge

gewuchtet G 6,3 - 20.000 U/min.

balanced G 6,3 - 20.000 r.p.m.

Verschluss der Kühlmittelezufuhr
für Werkzeuge mit Innenkühlung

Seal of the coolant supply
for tools with internal cooling

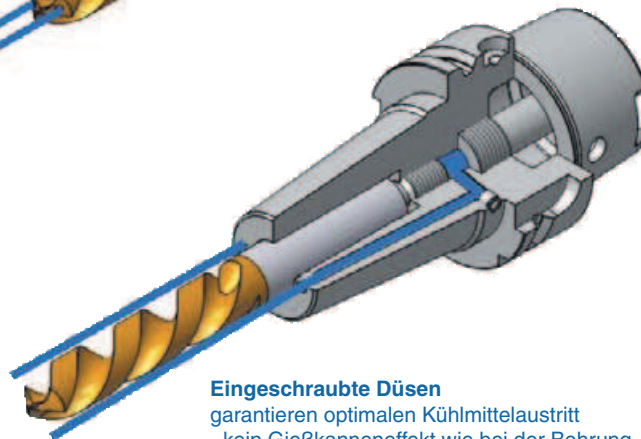
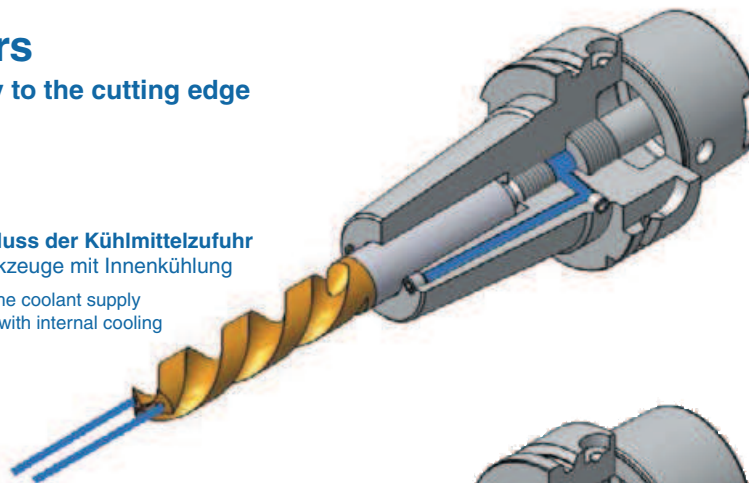

Eingeschraubte Düsen

garantieren optimalen Kühlmittelaustritt
- kein Gießkanneneffekt wie bei der Bohrung

Screwed in coolant nozzles guarantee
the best possible coolant flow
- no watering-can effect like in the case before

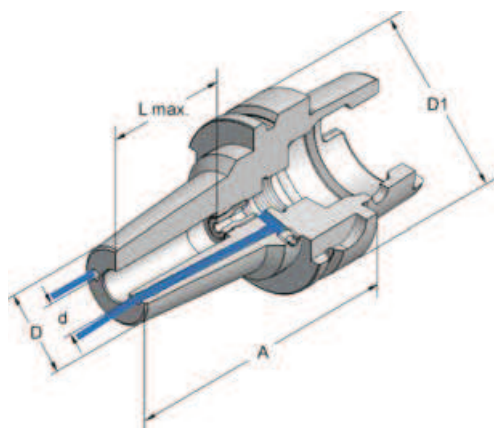

HSK - A 63

HSK - A 63

Art.-Nr.	Typ	D1	A	d	D	L	Art.-Nr.	Typ	D1	A	d	D	L
63.11.03.36	HSK-A63x03Sx 80	63	80	3	20	20	63.11.14.36	HSK-A63x14Sx 90	63	90	14	31	45
63.11.04.36	HSK-A63x04Sx 80	63	80	4	21	20	63.11.14.362	HSK-A63x14Sx130	63	130	14	31	45
63.11.06.36	HSK-A63x06Sx 80	63	80	6	23	38	63.11.16.36	HSK-A63x16Sx 95	63	95	16	33	50
63.11.06.362	HSK-A63x06Sx130	63	130	6	23	38	63.11.16.362	HSK-A63x16Sx130	63	130	16	33	50
63.11.06.363	HSK-A63x06Sx160	63	160	6	23	38	63.11.16.363	HSK-A63x16Sx160	63	160	16	33	50
63.11.08.36	HSK-A63x08Sx 80	63	80	8	25	38	63.11.18.36	HSK-A63x18Sx 95	63	95	18	35	50
63.11.08.362	HSK-A63x08Sx130	63	130	8	25	38	63.11.18.362	HSK-A63x18Sx130	63	130	18	35	50
63.11.08.363	HSK-A63x08Sx160	63	160	8	25	38	63.11.20.36	HSK-A63x20Sx100	63	100	20	37	55
63.11.10.36	HSK-A63x10Sx 85	63	85	10	27	42	63.11.20.362	HSK-A63x20Sx130	63	130	20	37	55
63.11.10.362	HSK-A63x10Sx130	63	130	10	27	42	63.11.25.36	HSK-A63x25Sx100	63	100	25	43	65
63.11.10.363	HSK-A63x10Sx160	63	160	10	27	42							
63.11.12.36	HSK-A63x12Sx 90	63	90	12	29	45							
63.11.12.362	HSK-A63x12Sx130	63	130	12	29	45							
63.11.12.363	HSK-A63x12Sx160	63	160	12	29	45							

Schrumpffutter ohne Kühlkanal

Shrink chuck

Rundlaufgenauigkeit HSK zu Werkzeugaufnahme < 0,005
 Concentricity from the taper to the holding part < 0,005

gewuchtet G 6,3 - 20.000 U/min.
 balanced G 6,3 - 20.000 r.p.m.

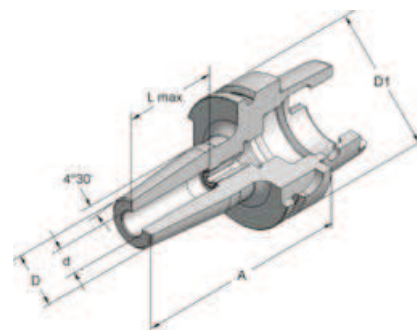

HSK - A 40

HSK - A 63

Art.-Nr.	Typ	D1	A	d	D	L	Art.-Nr.	Typ	D1	A	d	D	L		
40.11.03.31	HSK-A40x03Sx	65	40	65	3	11	20	63.11.03.31	HSK-A63x03Sx	80	63	80	3	11	20
40.11.04.31	HSK-A40x04Sx	65	40	65	4	14	20	63.11.04.31	HSK-A63x04Sx	80	63	80	4	14	20
40.11.06.31	HSK-A40x06Sx	65	40	65	6	21	40	63.11.06.31	HSK-A63x06Sx	80	63	80	6	21	40
40.11.08.31	HSK-A40x08Sx	65	40	65	8	21	40	63.11.08.31	HSK-A63x08Sx	80	63	80	8	21	40
40.11.10.31	HSK-A40x10Sx	65	40	65	10	24	42	63.11.10.31	HSK-A63x10Sx	85	63	85	10	24	42
40.11.12.31	HSK-A40x12Sx	70	40	70	12	24	47	63.11.12.31	HSK-A63x12Sx	90	63	90	12	24	47
40.11.14.31	HSK-A40x14Sx	70	40	70	14	27	47	63.11.14.31	HSK-A63x14Sx	90	63	90	14	27	47
40.11.16.31	HSK-A40x16Sx	75	40	75	16	27	50	63.11.16.31	HSK-A63x16Sx	95	63	95	16	27	50
40.11.20.31	HSK-A40x20Sx	75	40	75	20	27	50	63.11.18.31	HSK-A63x18Sx	95	63	95	18	33	50
HSK - E 40							63.11.20.31	HSK-A63x20Sx	95	63	95	20	33	52	
40.12.03.31	HSK-E40x03Sx	65	40	65	3	11	20	63.11.25.31	HSK-A63x25Sx	100	63	100	25	44	58
40.12.04.31	HSK-E40x04Sx	65	40	65	4	14	20	63.11.32.31	HSK-A63x32Sx	100	63	100	32	44	58
40.12.06.31	HSK-E40x06Sx	65	40	65	6	21	40								
40.12.08.31	HSK-E40x08Sx	65	40	65	8	21	40	63.11.06.32	HSK-A63x06Sx	130	63	130	6	21	40
40.12.10.31	HSK-E40x10Sx	65	40	65	10	24	42	63.11.08.32	HSK-A63x08Sx	130	63	130	8	21	40
40.12.12.31	HSK-E40x12Sx	70	40	70	12	24	47	63.11.10.32	HSK-A63x10Sx	130	63	130	10	24	42
40.12.14.31	HSK-E40x14Sx	70	40	70	14	27	47	63.11.12.32	HSK-A63x12Sx	130	63	130	12	24	47
40.12.16.31	HSK-E40x16Sx	75	40	75	16	27	50	63.11.14.32	HSK-A63x14Sx	130	63	130	14	27	47
40.12.20.31	HSK-E40x20Sx	75	40	75	20	27	52	63.11.16.32	HSK-A63x16Sx	130	63	130	16	27	50
HSK - C 40							63.11.18.32	HSK-A63x18Sx	130	63	130	18	33	50	
40.14.06.31	HSK-C40x06Sx	65	40	65	6	21	40	63.11.20.32	HSK-A63x20Sx	130	63	130	20	33	52
40.14.08.31	HSK-C40x08Sx	65	40	65	8	21	40	63.11.25.32	HSK-A63x25Sx	130	63	130	25	44	58
40.14.10.31	HSK-C40x10Sx	65	40	65	10	24	42								
40.14.12.31	HSK-C40x12Sx	70	40	70	12	24	47	63.11.06.33	HSK-A63x06Sx	160	63	160	6	21	40
40.14.14.31	HSK-C40x14Sx	70	40	70	14	27	47	63.11.08.33	HSK-A63x08Sx	160	63	160	8	21	40
40.14.16.31	HSK-C40x16Sx	75	40	75	16	27	50	63.11.10.33	HSK-A63x10Sx	160	63	160	10	24	42
HSK - E 50							63.11.12.33	HSK-A63x12Sx	160	63	160	12	24	47	
50.12.06.31	HSK-E50x06Sx	80	50	80	6	21	40	63.11.14.33	HSK-A63x14Sx	160	63	160	14	27	47
50.12.08.31	HSK-E50x08Sx	80	50	80	8	21	40	63.11.16.33	HSK-A63x16Sx	160	63	160	16	27	50
50.12.10.31	HSK-E50x10Sx	85	50	85	10	24	42	63.11.18.33	HSK-A63x18Sx	160	63	160	18	33	50
50.12.12.31	HSK-E50x12Sx	90	50	90	12	24	47	63.11.20.33	HSK-A63x20Sx	160	63	160	20	33	52
50.12.14.31	HSK-E50x14Sx	90	50	90	14	27	47	63.11.25.33	HSK-A63x25Sx	160	63	160	25	44	58
50.12.16.31	HSK-E50x16Sx	95	50	95	16	27	50								
50.12.20.31	HSK-E50x20Sx	95	50	95	20	33	52								
50.12.25.31	HSK-E50x25Sx	100	50	100	25	38	58								

HSK-A32, HSK-A50 + HSK-C50 auf Anfrage / on inquiry
 Sonderausführungen / Inch-Ausführungen auf Anfrage
 Special executions / inch-executions on inquiry

Dehnspannfutter Expansion chuck

Rundlaufgenauigkeit HSK zu Werkzeugaufnahme < 0,005
Concentricity from the taper to the holding part < 0,005

gewuchtet G 6,3 - 15.000 U/min.
balanced G 6,3 - 15.000 r.p.m.

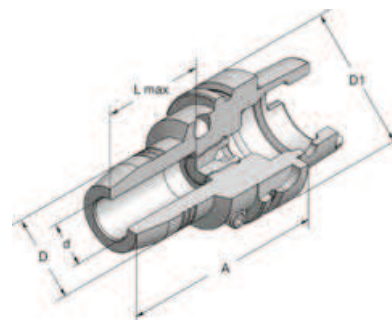

HSK - A 40							HSK - A 63										
Art.-Nr.	Typ	D1	A	d	D	L	Art.-Nr.	Typ	D1	A	d	D	L				
40.11.06.70	HSK-A40x06x70	40	70	6	26	37	63.11.06.70	HSK-A63x06x 70	63	70	6	26	37				
40.11.08.70	HSK-A40x08x70	40	70	8	28	37	63.11.08.70	HSK-A63x08x 70	63	70	8	28	37				
40.11.10.70	HSK-A40x10x75	40	75	10	30	41	63.11.10.70	HSK-A63x10x 80	63	80	10	30	41				
40.11.12.70	HSK-A40x12x80	40	80	12	32	46	63.11.12.70	HSK-A63x12x 85	63	85	12	32	46				
HSK - E 40							63.11.14.70	HSK-A63x14x 85	63	85	14	34	46				
40.12.06.70	HSK-E40x06x70	40	70	6	26	37	63.11.16.70	HSK-A63x16x 90	63	90	16	38	49				
40.12.08.70	HSK-E40x08x70	40	70	8	26	37	63.11.18.70	HSK-A63x18x 90	63	90	18	40	49				
40.12.10.70	HSK-E40x10x75	40	75	10	30	41	63.11.20.70	HSK-A63x20x 90	63	90	20	42	51				
40.12.12.70	HSK-E40x12x80	40	80	12	32	46	63.11.25.70	HSK-A63x25x120	63	120	25	57	57				
HSK - C 40							63.11.32.70	HSK-A63x32x125	63	125	32	64	61				
40.14.06.70	HSK-E40x06x60	40	60	6	26	37	Typ HSK-E63 + HSK-F63 auf Anfrage										
40.14.08.70	HSK-E40x08x60	40	60	8	28	37	Zwischenbüchsen Intermediate										
40.14.10.70	HSK-E40x10x65	40	65	10	30	41											
40.14.12.70	HSK-E40x12x70	40	70	12	32	46	Art.-Nr.	Typ	d	D							
HSK - A 50							50.11.06.70	HSK-A50x06x70	50	70	6	26	37	204 370	GZB-S12/03	3	12
50.11.08.70	HSK-A50x08x70	50	70	8	28	37	50.11.10.70	HSK-A50x10x75	50	75	10	30	41	204 371	GZB-S12/04	4	12
50.11.12.70	HSK-A50x12x80	50	80	12	32	46	50.11.16.70	HSK-A50x16x90	50	90	16	38	49	204 372	GZB-S12/05	5	12
50.11.20.70	HSK-A50x20x90	50	90	20	42	51	50.11.20.70	HSK-A50x20x90	50	90	20	42	51	204 373	GZB-S12/06	6	12
HSK - E 50							50.12.06.70	HSK-E50x06x70	50	70	6	26	37	204 374	GZB-S12/08	8	12
50.12.08.70	HSK-E50x08x70	50	70	8	28	37	50.12.10.70	HSK-E50x10x75	50	75	10	30	41	204 375	GZB-S12/10	10	12
50.12.12.70	HSK-E50x12x80	50	80	12	32	46	50.12.16.70	HSK-E50x16x90	50	90	16	38	49	203 197	GZB-S20/03	3	20
50.12.20.70	HSK-E50x20x90	50	90	20	42	51	50.12.20.70	HSK-E50x20x90	50	90	20	42	51	203 198	GZB-S20/04	4	20
HSK - C 50							50.14.06.70	HSK-C50x06x60	50	60	6	26	37	203 199	GZB-S20/05	5	20
50.14.08.70	HSK-C50x08x60	50	60	8	28	37	50.14.10.70	HSK-C50x10x65	50	65	10	30	41	203 200	GZB-S20/06	6	20
50.14.12.70	HSK-C50x12x70	50	70	12	32	46	50.14.12.70	HSK-C50x12x70	50	70	12	32	46	203 201	GZB-S20/08	8	20
50.14.16.70	HSK-C50x16x80	50	80	16	38	49	50.14.16.70	HSK-C50x16x80	50	80	16	38	49	203 202	GZB-S20/10	10	20
50.14.20.70	HSK-C50x20x80	50	80	20	42	51	50.14.20.70	HSK-C50x20x80	50	80	20	42	51	203 203	GZB-S20/12	12	20
														203 204	GZB-S20/14	14	20
														203 205	GZB-S20/16	16	20
														204 320	GZB-S32/06	6	32
														204 321	GZB-S32/08	8	32
														204 322	GZB-S32/10	10	32
														204 323	GZB-S32/12	12	32
														204 324	GZB-S32/14	14	32
														204 325	GZB-S32/16	16	32
														204 326	GZB-S32/18	18	32
														204 327	GZB-S32/20	20	32
														204 328	GZB-S32/25	25	32

Aufnahme für Einschraubfräser HSK - A63
Adaptor for end mills with thread shank

Rundlaufgenauigkeit HSK zu Werkzeugaufnahme < 0,005
 Concentricity from the taper to the holding part < 0,005

gewuchtet G 6,3 - 20.000 U/min.
 balanced G 6,3 - 20.000 r.p.m.

Sonderausführungen auf Anfrage
 Special executions on inquiry

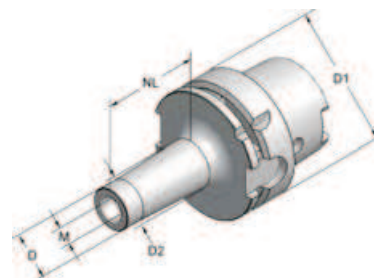

HSK - A 63							HSK - A 63						
Art.-Nr.	Typ	D1	M	NL	D	D2	Art.-Nr.	Typ	D1	M	NL	D	D2
63.11.06.025	HSK-A63xM 6x 25	63	6	25	9,7	10	63.11.12.025	HSK-A63xM12x 25	63	12	25	21	24
63.11.06.050	HSK-A63xM 6x 50	63	6	50	9,7	20	63.11.12.050	HSK-A63xM12x 50	63	12	50	21	24
63.11.06.075	HSK-A63xM 6x 75	63	6	75	9,7	23	63.11.12.075	HSK-A63xM12x 75	63	12	75	21	31
63.11.06.100	HSK-A63xM 6x100	63	6	100	9,7	25	63.11.12.100	HSK-A63xM12x100	63	12	100	21	31
63.11.08.025	HSK-A63xM 8x 25	63	8	25	13	15	63.11.12.150	HSK-A63xM12x150	63	12	150	21	36
63.11.08.050	HSK-A63xM 8x 50	63	8	50	13	23	63.11.12.200	HSK-A63xM12x200	63	12	200	21	36
63.11.08.075	HSK-A63xM 8x 75	63	8	75	13	23	63.11.16.025	HSK-A63xM16x 25	63	16	25	29	34
63.11.08.100	HSK-A63xM 8x100	63	8	100	13	25	63.11.16.050	HSK-A63xM16x 50	63	16	50	29	34
63.11.10.025	HSK-A63xM10x 25	63	10	25	18	20	63.11.16.075	HSK-A63xM16x 75	63	16	75	29	34
63.11.10.050	HSK-A63xM10x 50	63	10	50	18	25	63.11.16.100	HSK-A63xM16x100	63	16	100	29	39
63.11.10.075	HSK-A63xM10x 75	63	10	75	18	28	63.11.16.150	HSK-A63xM16x150	63	16	150	29	39
63.11.10.100	HSK-A63xM10x100	63	10	100	18	30	63.11.16.200	HSK-A63xM16x200	63	16	200	29	39

Gewindeschneid-Schnellwechselfutter mit elastischem Längenauszug auf Druck und Zug
Thread cutting quick-change chuck with smooth-action length compensation for pressure and tension

Einsätze mit Rutschkupplung
Tapping collets with clutch

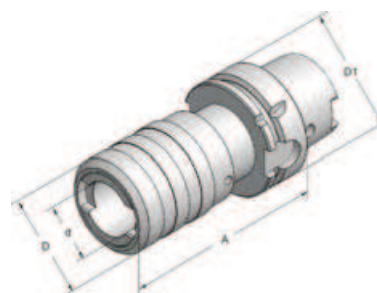

Gr.1 M3 - M12		HSK - A 50					
Art.-Nr.	Typ	Art.-Nr.	Typ	D1	A	d	D
100035	ø 3,50-M3+M4	50.11.12.14	HSK- A50xM3-M14	50	72	19	38
100045	ø 4,50-M4+M6	50.11.20.14	HSK- A50xM8-M22	50	110	31	54
100060	ø 6,00-M5+M6+M8	HSK - A 63					
100070	ø 7,00-M7+M9+M10	63.11.12.14	HSK- A63xM3-M14	63	72	19	38
100080	ø 8,00-M8+M11	63.11.20.14	HSK- A63xM8-M22	63	110	31	54
100090	ø 9,00-M9+M12	HSK - A 100					
100100	ø10,00-M10	100.11.12.14	HSK-A100xM3-M14	100	80	19	38
Gr.2 M8 - M20		100.11.20.14	HSK-A100xM8-M22	100	112	31	54
200080	ø 8,00-M8+M11						
200090	ø 9,00-M9+M12						
200100	ø10,00-M10						
200110	ø11,00-M14						
200120	ø12,00-M12+M16						
200140	ø14,00-M18						
200160	ø16,00-M20						

Prüfdorn in Holzetui
Control arbors in wooden case

Rundlaufgenauigkeit < 0,005
 Concentricity < 0,005

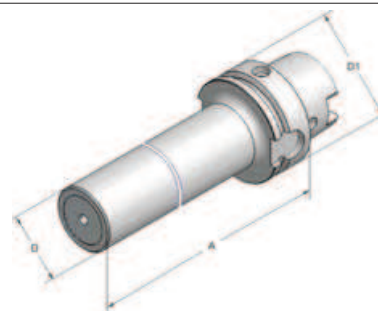

Art.-Nr.	Typ	D1	A	D
	HSK - A 40			
40.11.180	HSK-A40x180	40	180	24
	HSK - E 40			
40.12.180	HSK-E40x180	40	180	24
	HSK - A 50			
50.11.225	HSK-A50x225	50	225	32
	HSK - E 50			
50.12.225	HSK-E50x225	50	225	32
	HSK - A 63			
63.11.345	HSK-A63x345	63	345	40
	SK - 30/40/50			
30.05.200	SK-30x30x200	SK30	200	30
40.05.315	SK-40x30x315	SK40	315	30
50.05.315	SK-50x50x315	SK50	315	50

Rohling
Blank

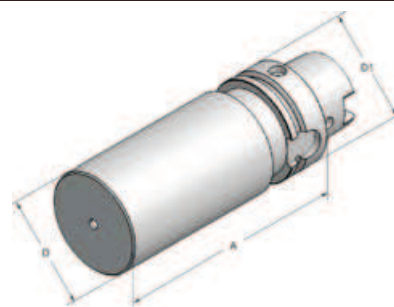

Art.-Nr.	Typ	D1	A	D	Art.-Nr.	Typ	D1	A	D
	HSK - A 40					HSK - A 50			
40.11.120.15	HSK-A40x120	40	120	43	50.11.150.15	HSK-A50x150	50	150	50
	HSK - E 40					HSK - E 50			
40.12.120.15	HSK-E40x120	40	120	43	50.12.150.15	HSK-E50x150	50	150	50
						HSK - A 63			
					63.11.200.15	HSK-A63x200	63	200	63

Kühlmittelübergaberohr
Connection for coolant tube

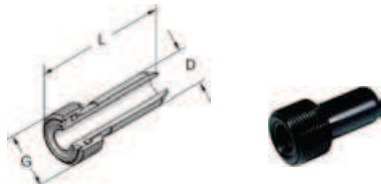

Steckschlüssel für Kühlmittelübergaberohr
Socket wrench for connection



Wischer für Konus und Stirnseite
Cone cleaner

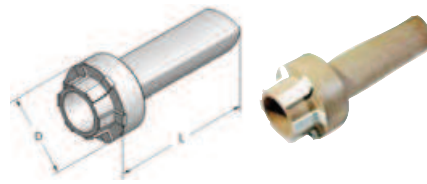

Art.-Nr.	Typ	G	D	L	Art.-Nr.	Typ	D	L	Art.-Nr.	Typ	D	L
460101	HSK- 40	12x1	8	30	469101	HSK- 40	10,5	115	269100	HSK- 40	45	127
461101	HSK- 50	16x1	10	33	465101	HSK- 50	14,5	115	281100	HSK- 50	53	135
462101	HSK- 63	18x1	12	37	466101	HSK- 63	16,5	132	282100	HSK- 63	65	145
464101	HSK-100	24x1,5	16	44	468101	HSK-100	22,0	135	283100	HSK-100	105	160

Räumwerkzeughalter für Innenprofile

Broaching toolholders for internal profiles

Reduzierung
Reduction

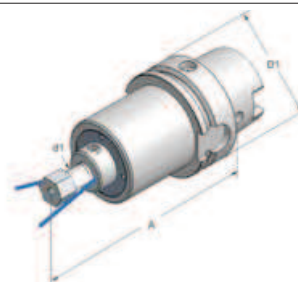

Räumstempel siehe Seite 21
Hexagonal broach see page 21



Sonderprofile auf Anfrage
Special executions on inquiry

Art.-Nr.	Typ	D1	A	d1
HSK - E 40				
40.12.08.5000	HSK-E40x08x 95	40	95	8
HSK - C 50				
50.14.12.5000	HSK-C50x12x100	50	100	12
HSK - A 63				
63.11.12.5000	HSK-A63x12x115	63	115	12
Coromant Capto				
C5.12.5000	C5x12x100	50	100	12
C6.12.5000	C6x12x115	63	115	12
Reduzierung				
1208.5000				

Adapter HSK DIN 69893 auf HSK DIN 69893

Adapter SK DIN 69871 / BT auf HSK DIN 69893

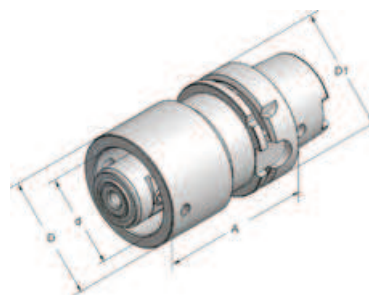

DIN 69871



HSK - A 63



MAS BT

Art.-Nr.	Typ	SK	HSK	A	D	Art.-Nr.	Typ	D1	HSK	A	D
40.01.50A	TC40xHSK-A50-AD+B	40	50	50	50	63.11.63A- 90	HSK-A63xA63x 90	63	63	90	63
40.01.50E	TC40xHSK-E50-AD+B	40	50	50	50	63.11.63A-120	HSK-A63xA63x120	63	63	120	63
40.01.63A	TC40xHSK-A63-AD+B	40	63	75	63	MAS BT					
40.01.63E	TC40xHSK-E63-AD+B	40	63	75	63						
50.01.50A	TC50xHSK-A50-AD+B	50	50	50	50						
50.01.50E	TC50xHSK-E50-AD+B	50	50	50	50	40.05.50A	BT40xHSK-A50-AD+B	50	50	50	
50.01.63A	TC50xHSK-A63-AD+B	50	63	50	63	40.05.63A	BT40xHSK-A63-AD+B	63	75	63	

Auswucht - Service / Balancing - Service

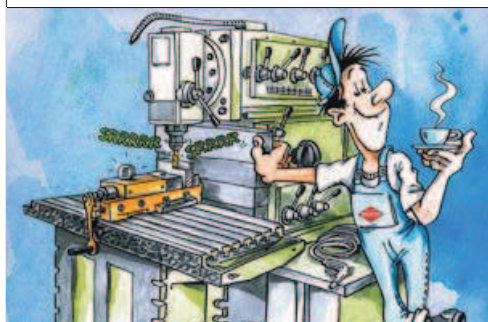

Art.-Nr.	Wuchtgüte
2520	G 2,5 - 20.000 U/min
2525	G 2,5 - 25.000 U/min
2530	G 2,5 - 30.000 U/min
2540	G 2,5 - 40.000 U/min
6320	G 6,3 - 20.000 U/min
6330	G 6,3 - 30.000 U/min
6340	G 6,3 - 40.000 U/min



HSK - A63 Drehhalter 1-fach
HSK - A63 single turning toolholder

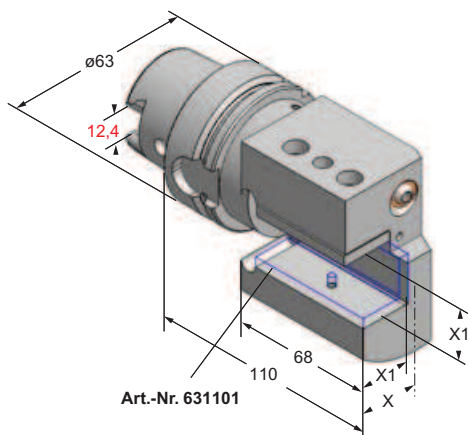

HSK - A 63

Art.-Nr.	X	X1
63.11.25.050	30	25
63.11.20.0501	20	20
631101	Reduzierung □ 25/20	

HSK - A63 Drehhalter 2-fach
HSK - A63 double turning toolholder

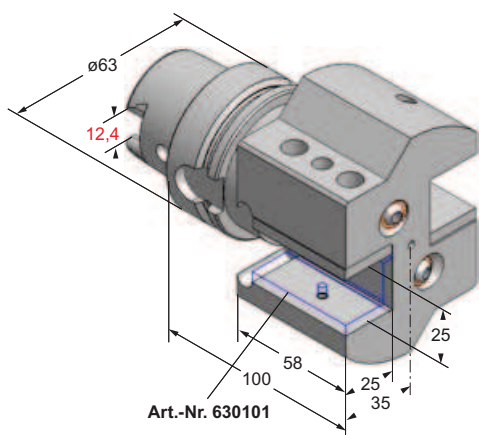

HSK - A 63

Art.-Nr.	
63.11.25.151	Ausführung L wie abgebildet / left hand design as shown
63.11.25.171	Ausführung R spiegelbildlich / right hand design reversed
631101	Reduzierung □ 25/20

HSK - A63 Drehhalter 3-fach
HSK - A63 triple turning toolholder

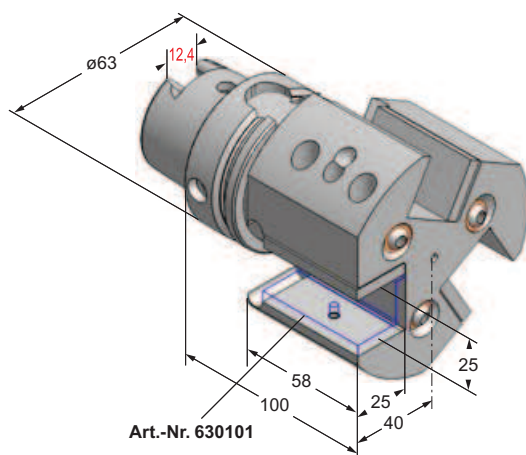

HSK - A 63

Art.-Nr.	
63.11.25.190	Ausführung L wie abgebildet / left hand design as shown
63.11.25.180	Ausführung R spiegelbildlich / right hand design reversed
631101	Reduzierung □ 25/20

Bohrstangenaufnahme $\phi 6 - 32$
Boring bar holder $\phi 6 - 32$

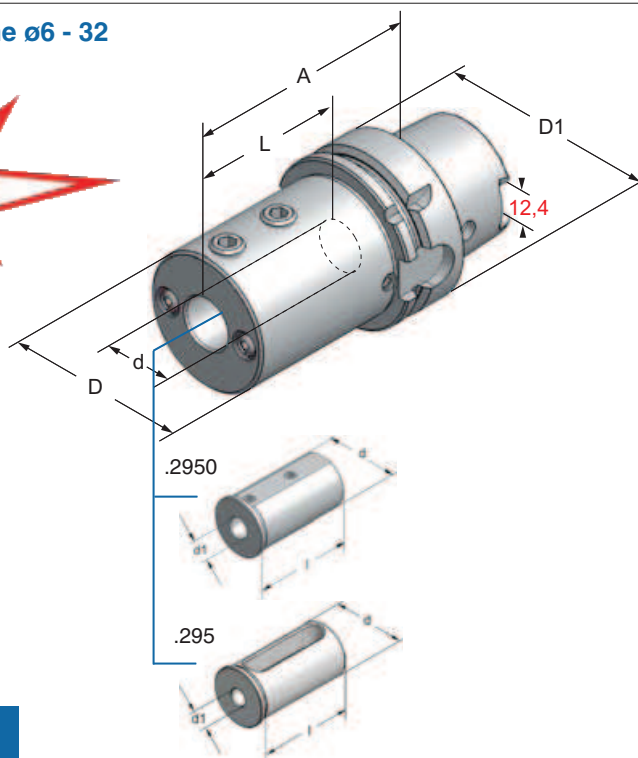

Reduzierbuchse
Reduction bushes



Bohrstangenaufnahme
Boring bar holder

Art.-Nr.	Typ	d	D	D1	L	A
63.11.06.290	HSK-A63x06x90	6	38	63	65	90
63.11.08.290	HSK-A63x08x90	8	40	63	65	90
63.11.10.290	HSK-A63x10x90	10	42	63	65	90
63.11.12.290	HSK-A63x12x90	12	44	63	65	90
63.11.16.290	HSK-A63x16x90	16	48	63	65	90
63.11.20.290	HSK-A63x20x90	20	52	63	65	90
63.11.25.290	HSK-A63x25x90	25	57	63	65	90
63.11.32.290	HSK-A63x32x90	32	64	63	65	90

Reduzierbuchse
Reduction bush

Art.-Nr.	d
32.06.2950	6
32.08.2950	8
32.10.2950	10
32.12.295	12
32.14.295	14
32.16.295	16
32.18.295	18
32.20.295	20
32.25.295	25

Bohrerhalter für U-Bohrer
Holder for T-max U-drills

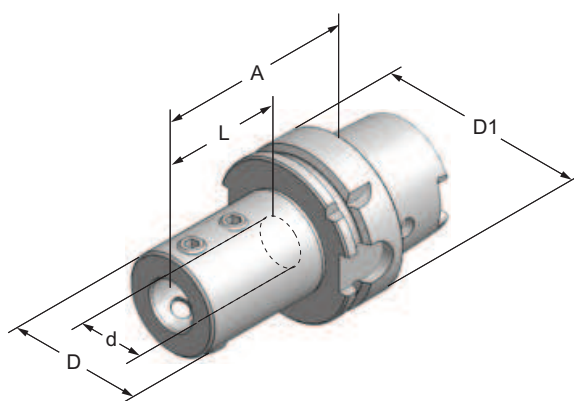

HSK - A 63

Art.-Nr.	Typ	d	D	D1	L	A
63.11.16.220	HSK-A63x16x 80	16	34	63	54	82
63.11.20.220	HSK-A63x20x 80	20	40	63	54	80
63.11.25.220	HSK-A63x25x 85	25	45	63	59	85
63.11.32.220	HSK-A63x32x 90	32	52	63	63	90
63.11.40.220	HSK-A63x40x100	40	60	63	73	100

HSK - A63 Drehhalter Typ PCLN R/L
HSK - A63 turning toolholder PCLN R/L

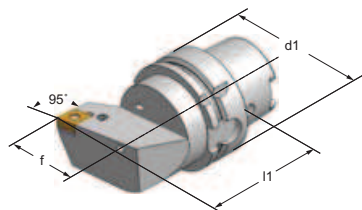

Ausführung L wie abgebildet, Ausführung R spiegelbildlich
 Left hand design as shown, right hand design reversed

Art.-Nr.	d1	f	l1	Insert
63.11.1001 R	63	45	70	CNMG 1204 ...
63.11.1002 L	63	45	70	CNMG 1204 ...

HSK - A63 Drehhalter Typ PDJN R/L
HSK - A63 turning toolholder PDJN R/L

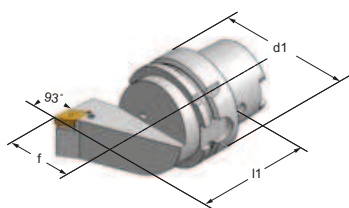

Ausführung L wie abgebildet, Ausführung R spiegelbildlich
 Left hand design as shown, right hand design reversed

Art.-Nr.	d1	f	l1	Insert
63.11.1006 R	63	45	70	DNMG 1204 ...
63.11.1007 L	63	45	70	DNMG 1204 ...

HSK - A63 Drehhalter Typ SDNC
HSK - A63 turning toolholder SDNC

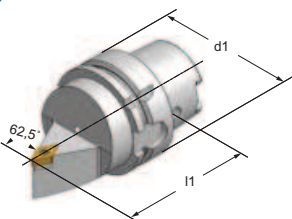

Art.-Nr.	d1	l1	Insert
63.11.1015	63	75	DC .. 11T3 ...

HSK - A63 Drehhalter Typ SDJC R/L
HSK - A63 turning toolholder SDJC R/L

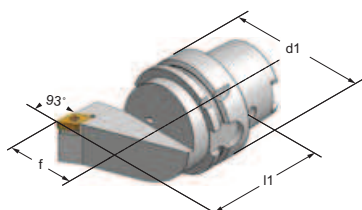

Ausführung L wie abgebildet, Ausführung R spiegelbildlich
 Left hand design as shown, right hand design reversed

Art.-Nr.	d1	f	l1	Insert
63.11.1011 R	63	45	70	DC .. 11T3 ...
63.11.1012 L	63	45	70	DC .. 11T3 ...

HSK - A63 Drehhalter Typ SVJB R/L
HSK - A63 turning toolholder SVJB R/L

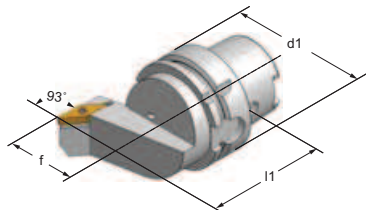

Ausführung L wie abgebildet, Ausführung R spiegelbildlich
 Left hand design as shown, right hand design reversed

Art.-Nr.	d1	f	l1	Insert
63.11.1019 R	63	45	70	VC .. 1604 ...
63.11.1020 L	63	45	70	VC .. 1604 ...

HSK - A63 Drehhalter Typ SVHC R/L
HSK - A63 turning toolholder SVHC R/L

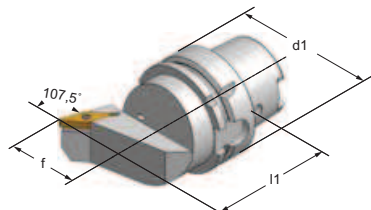

Ausführung L wie abgebildet, Ausführung R spiegelbildlich
 Left hand design as shown, right hand design reversed

Art.-Nr.	d1	f	l1	Insert
63.11.1021 R	63	45	70	VC .. 1604 ...
63.11.1022 L	63	45	70	VC .. 1604 ...

Schleifscheiben-Aufnahme HSK
Grinding wheel adaptor HSK

Komplett mit Flanschscheiben
 Complete with flange wheel

Sonderausführungen nach Kundenwunsch lieferbar
 Special requirements available



HSK - C 50

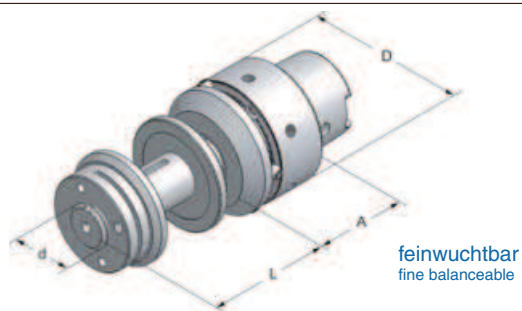

Art.-Nr.	Typ	D	d	A	L
111650	HSK-C50x20x106	54	20	40	66
112650	HSK-C50x20x140	54	20	40	100

HSK - E 50

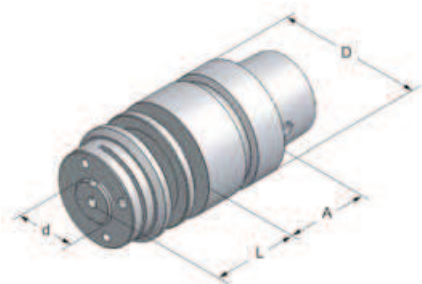

Art.-Nr.	Typ	D	d	A	L
114650	HSK-E50x20x 82	50	20	42	40
115650	HSK-E50x20x102	50	20	42	60

HSK - F 50

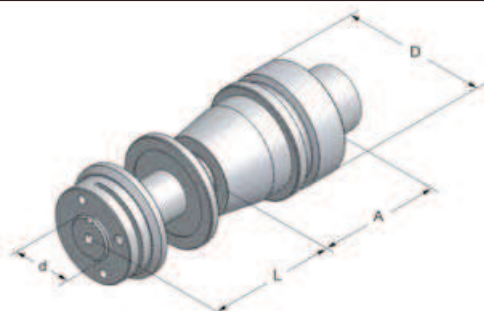

Art.-Nr.	Typ	D	d	A	L
125650	HSK-F50x20x58	50	20	58	60
126650	HSK-F50x20x88	50	20	88	60



415 E		462 E		467 E		467 E	
Art.-Nr.	Typ	Art.-Nr.	Typ	Art.-Nr.	Typ	Art.-Nr.	Typ
415020	ø2,0 - 1,5	462020	ø2,0 - 1,5			467165	ø16,5 - 16,0
415025	ø2,5 - 2,0	462025	ø2,5 - 2,0			467170	ø17,0 - 16,5
415030	ø3,0 - 2,5	462030	ø3,0 - 2,5			467175	ø17,5 - 17,0
415035	ø3,5 - 3,0	462035	ø3,5 - 3,0			467180	ø18,0 - 17,5
415040	ø4,0 - 3,5	462040	ø4,0 - 3,5	467040	ø4,0 - 3,5	467185	ø18,5 - 18,0
415045	ø4,5 - 4,0	462045	ø4,5 - 4,0	467045	ø4,5 - 4,0	467190	ø19,0 - 18,5
415050	ø5,0 - 4,5	462050	ø5,0 - 4,5	467050	ø5,0 - 4,5	467195	ø19,5 - 19,0
415055	ø5,5 - 5,0	462055	ø5,5 - 5,0	467055	ø5,5 - 5,0	467200	ø20,0 - 19,5
415060	ø6,0 - 5,5	462060	ø6,0 - 5,5	467060	ø6,0 - 5,5	467205	ø20,5 - 20,0
415065	ø6,5 - 6,0	462065	ø6,5 - 6,0	467065	ø6,5 - 6,0	467210	ø21,0 - 20,5
415070	ø7,0 - 6,5	462070	ø7,0 - 6,5	467070	ø7,0 - 6,5	467215	ø21,5 - 21,0
415075	ø7,5 - 6,5	462075	ø7,5 - 7,0	467075	ø7,5 - 7,0	467220	ø22,0 - 21,5
415080	ø8,0 - 7,5	462080	ø8,0 - 7,5	467080	ø8,0 - 7,5	467225	ø22,5 - 22,0
415085	ø8,5 - 8,0	462085	ø8,5 - 8,0	467085	ø8,5 - 8,0	467230	ø23,0 - 22,5
415090	ø9,0 - 8,5	462090	ø9,0 - 8,5	467090	ø9,0 - 8,5	467235	ø23,5 - 23,0
415095	ø9,5 - 9,0	462095	ø9,5 - 9,0	467095	ø9,5 - 9,0	467240	ø24,0 - 23,5
415100	ø10,0 - 9,5	462100	ø10,0 - 9,5	467100	ø10,0 - 9,5	467245	ø24,5 - 24,0
415105	ø10,5 - 10,0	462105	ø10,5 - 10,0	467105	ø10,5 - 10,0	467250	ø25,0 - 24,5
415110	ø11,0 - 10,5	462110	ø11,0 - 10,5	467110	ø11,0 - 10,5	467255	ø25,5 - 25,0
415115	ø11,5 - 11,0	462115	ø11,5 - 11,0	467115	ø11,5 - 11,0	467260	ø26,0 - 25,5
415120	ø12,0 - 11,5	462120	ø12,0 - 11,5	467120	ø12,0 - 11,5	467265	ø26,5 - 26,0
415125	ø12,5 - 12,0	462125	ø12,5 - 12,0	467125	ø12,5 - 12,0	467270	ø27,0 - 26,5
415130	ø13,0 - 12,5	462130	ø13,0 - 12,5	467130	ø13,0 - 12,5	467275	ø27,5 - 27,0
415135	ø13,5 - 13,0	462135	ø13,5 - 13,0	467135	ø13,5 - 13,0	467280	ø28,0 - 27,5
415140	ø14,0 - 13,5	462140	ø14,0 - 13,5	467140	ø14,0 - 13,5	467285	ø28,5 - 28,0
415145	ø14,5 - 14,0	462145	ø14,5 - 14,0	467145	ø14,5 - 14,0	467290	ø29,0 - 28,5
415150	ø15,0 - 14,5	462150	ø15,0 - 14,5	467150	ø15,0 - 14,5	467295	ø29,5 - 29,0
415155	ø15,5 - 15,0	462155	ø15,5 - 15,0	467155	ø15,5 - 15,0	467300	ø30,0 - 29,5
415160	ø16,0 - 15,5	462160	ø16,0 - 15,5	467160	ø16,0 - 15,5	467305	ø30,5 - 30,0
		462165	ø16,5 - 16,0			467310	ø31,0 - 30,5
		462170	ø17,0 - 16,5			467315	ø31,5 - 31,0
		462175	ø17,5 - 17,0			467320	ø32,0 - 31,5
		462180	ø18,0 - 17,5				
		462185	ø18,5 - 18,0				
		462190	ø19,0 - 18,5				
		462195	ø19,5 - 19,0				
		462200	ø20,0 - 19,5				
		462205	ø20,5 - 20,0				
		462210	ø21,0 - 20,5				
		462215	ø21,5 - 21,0				
		462220	ø22,0 - 21,5				
		462225	ø22,5 - 22,0				
		462230	ø23,0 - 22,5				
		462235	ø23,5 - 23,0				
		462240	ø24,0 - 23,5				
		462245	ø24,5 - 24,0				
		462250	ø25,0 - 24,5				

Spannzangen ER/ESX DIN 6499-B

Collets type ER/ESX DIN 6499-B



Original rego-fix



ER 8		ER 11/424 E		ER 16/426 E		ER 20/428 E	
Art.-Nr.	Typ	Art.-Nr.	Typ	Art.-Nr.	Typ	Art.-Nr.	Typ
108001	Satz / Set	111001	Satz / Set	116001	Satz / Set	120001	Satz / Set
		111001.	Satz / Set	116001.	Satz / Set	120001.	Satz / Set
9 Stück/pcs.		13 Stück/pcs.		10 Stück/pcs.		12 Stück/pcs.	
108010	ø1,0 - 0,5	111010	ø1,0 - 0,5	116010	ø1,0 - 0,5	120010	ø1,0 - 0,5
108015	ø1,5 - 1,0	111015	ø1,5 - 1,0	116020	ø2,0 - 1,0	120020	ø2,0 - 1,0
108020	ø2,0 - 1,5	111020	ø2,0 - 1,5	116030	ø3,0 - 2,0	120030	ø3,0 - 2,0
108025	ø2,5 - 2,0	111025	ø2,5 - 2,0	116040	ø4,0 - 3,0	120040	ø4,0 - 3,0
108030	ø3,0 - 2,5	111030	ø3,0 - 2,5	116050	ø5,0 - 4,0	120050	ø5,0 - 4,0
108035	ø3,5 - 3,0	111035	ø3,5 - 3,0	116060	ø6,0 - 5,0	120060	ø6,0 - 5,0
108040	ø4,0 - 3,5	111040	ø4,0 - 3,5	116070	ø7,0 - 6,0	120070	ø7,0 - 6,0
108045	ø4,5 - 4,0	111045	ø4,5 - 4,0	116080	ø8,0 - 7,0	120080	ø8,0 - 7,0
108050	ø5,0 - 4,5	111050	ø5,0 - 4,5	116090	ø9,0 - 8,0	120090	ø9,0 - 8,0
		111055	ø5,5 - 5,0	116100	ø10,0 - 9,0	120100	ø10,0 - 9,0
		111060	ø6,0 - 5,5	ER 40/472 E		120110	ø11,0 - 10,0
		111065	ø6,5 - 6,0	140001	Satz / Set	120120	ø12,0 - 11,0
		111070	ø7,0 - 6,5	140001.	Satz / Set	120130	ø13,0 - 12,0
ER 25/430 E		ER 32/470 E		23 Stück/pcs.		ER 50/474 E	
125001	Satz / Set	132001	Satz / Set	140030	ø3,0 - 2,0	150001	Satz / Set
125001.	Satz / Set	132001.	Satz / Set	140040	ø4,0 - 3,0	12 Stück/pcs.	
15 Stück/pcs.		18 Stück/pcs.		140050	ø5,0 - 4,0	150060	ø6,0 - 5,0
125010	ø1,0 - 0,5			140060	ø6,0 - 5,0	150080	ø8,0 - 6,0
125020	ø2,0 - 1,0	132020	ø2,0 - 1,0	140070	ø7,0 - 6,0	150100	ø10,0 - 8,0
125030	ø3,0 - 2,0	132030	ø3,0 - 2,0	140080	ø8,0 - 7,0	150120	ø12,0 - 10,0
125040	ø4,0 - 3,0	132040	ø4,0 - 3,0	140090	ø9,0 - 8,0	150140	ø14,0 - 12,0
125050	ø5,0 - 4,0	132050	ø5,0 - 4,0	140100	ø10,0 - 9,0	150160	ø16,0 - 14,0
125060	ø6,0 - 5,0	132060	ø6,0 - 5,0	140110	ø11,0 - 10,0	150180	ø18,0 - 16,0
125070	ø7,0 - 6,0	132070	ø7,0 - 6,0	140120	ø12,0 - 11,0	150200	ø20,0 - 18,0
125080	ø8,0 - 7,0	132080	ø8,0 - 7,0	140130	ø13,0 - 12,0	150220	ø22,0 - 20,0
125090	ø9,0 - 8,0	132090	ø9,0 - 8,0	140140	ø14,0 - 13,0	150240	ø24,0 - 22,0
125100	ø10,0 - 9,0	132100	ø10,0 - 9,0	140150	ø15,0 - 14,0	150250	ø25,0 - 23,0
125110	ø11,0 - 10,0	132110	ø11,0 - 10,0	140160	ø16,0 - 15,0	150260	ø26,0 - 24,0
125120	ø12,0 - 11,0	132120	ø12,0 - 11,0	140170	ø17,0 - 16,0	150280	ø28,0 - 26,0
125130	ø13,0 - 12,0	132130	ø13,0 - 12,0	140180	ø18,0 - 17,0	150300	ø30,0 - 28,0
125140	ø14,0 - 13,0	132140	ø14,0 - 13,0	140190	ø19,0 - 18,0	150320	ø32,0 - 30,0
125150	ø15,0 - 14,0	132150	ø15,0 - 14,0	140200	ø20,0 - 19,0	150340	ø34,0 - 32,0
125160	ø16,0 - 15,0	132160	ø16,0 - 15,0	140210	ø21,0 - 20,0		
		132170	ø17,0 - 16,0	140220	ø22,0 - 21,0		
		132180	ø18,0 - 17,0	140230	ø23,0 - 22,0		
		132190	ø19,0 - 18,0	140240	ø24,0 - 23,0		
		132200	ø20,0 - 19,0	140250	ø25,0 - 24,0		
				140260	ø26,0 - 25,0		
				140270	ø27,0 - 26,0		
				140280	ø28,0 - 27,0		
				140290	ø29,0 - 28,0		
				140300	ø30,0 - 29,0		
Sätze mit . z.B. 125001. nicht Original rego-fix							
Sets with . e.g. 125001. no original rego-fix							



Gewindebohrzangen ohne Längenausgleich

Zubehör + Ersatzteile

Tapping collets without axial compensation / Accessories and spare parts



Original rego-fix



ER 16-GB		ER 25-GB		ER 32-GB		ER 40-GB	
Art.-Nr.	Typ	Art.-Nr.	Typ	Art.-Nr.	Typ	Art.-Nr.	Typ
GB116045	ø4,5x3,4	GB125045	ø4,5x3,4	GB132045	ø4,5x 3,4	GB140070	ø7,0x 5,5
GB116055	ø5,5x4,3	GB125055	ø5,5x4,3	GB132055	ø5,5x 4,3	GB140080	ø8,0x 6,2
GB116060	ø6,0x4,9	GB125060	ø6,0x4,9	GB132060	ø6,0x 4,9	GB140090	ø9,0x 7,0
GB116070	ø7,0x5,5	GB125070	ø7,0x5,5	GB132070	ø7,0x 5,5	GB140100	ø10,0x 8,0
ER 20-GB		GB125080	ø8,0x6,2	GB132080	ø8,0x 6,2	GB140110	ø11,0x 9,0
GB120045	ø4,5x3,4	GB125090	ø9,0x7,0	GB132090	ø9,0x 7,0	GB140120	ø12,0x 9,0
GB120055	ø5,5x4,3	GB125100	ø10,0x8,0	GB132100	ø10,0x 8,0	GB140140	ø14,0x11,0
GB120060	ø6,0x4,9	GB125110	ø11,0x9,0	GB132110	ø11,0x 9,0	GB140160	ø16,0x12,0
GB120070	ø7,0x5,5	GB125120	ø12,0x9,0	GB132120	ø12,0x 9,0	GB140180	ø18,0x14,5
GB120080	ø8,0x6,2			GB132140	ø14,0x11,0	GB140200	ø20,0x16,0
GB120090	ø9,0x7,0			GB132160	ø16,0x12,0	GB140220	ø22,0x18,0
GB120100	ø10,0x8,0						
Hakenschlüssel mini Hook spanner mini		Schlüssel DIN 6368 Key DIN 6368		Mitnehmerring DIN 6366 Clutch drive rings to DIN 6366		Fräseranzugschraube DIN 6367 Drawn - in bolt to DIN 6367	
Art.-Nr.	Typ	Art.-Nr.	Typ	Art.-Nr.	Typ	Art.-Nr.	Typ
908160	E 8 mini	170101	ø16	160101	ø16x10	163100	M 8x ø16
911160	E 11 mini	171101	ø22	161101	ø22x12	164100	M10x ø22
916160	E 16 mini	172101	ø27	162101	ø27x12	165100	M12x ø27
920160	E 20 mini	173101	ø32	163101	ø32x14	166100	M16x ø32
925160	E 25 mini	174101	ø40	164101	ø40x14	167100	M20x ø40
				165101	ø50x16	168100	M24x ø50
Hakenschlüssel Hook spanner		Wischer für SK + MK Cone cleaner SK + MK		Spannschraube Weldon Clamping screw Weldon		Gewindebohrzangen PCM ET1 mit Längenausgleich	
Art.-Nr.	Typ	Art.-Nr.	Typ	Art.-Nr.	Typ	Art.-Nr.	Typ
911180	GS 17	284100	SK 30	147100	M 6x10	ET1-16...	M1 - M 6
916180	GS 25	285100	SK 40	148100	M 8x10	ET1-20...	M1 - M 8
920180	GS 30	286100	SK 50	149100	M10x12	ET1-25...	M3 - M12
916181	E 16	341100	MK 2	150100	M12x16	ET1-32...	M4 - M16
920181	E 20	342100	MK 3	151100	M14x16	ET1-40...	M6 - M20
932180	E 32	343100	MK 4	152100	M16x16	Gewindebohrerschaft ø angeben	
932180	E 32	344100	MK 5	153100	M18x2x20	Please indicate tap shank ø	
940180	E 40			154100	M20x2x20		
950180	E 50						



<p>Spannmutter DIN 6499 Clamping nut DIN 6499</p>  <p>711120 716120</p>	<table border="1"> <thead> <tr> <th>Art.-Nr.</th> <th>Typ</th> <th>D</th> <th>b</th> <th>G</th> <th>Nm max.</th> </tr> </thead> <tbody> <tr><td>711120</td><td>UMQ / ER11</td><td>19</td><td>11</td><td>M 14x0,75</td><td>30</td></tr> <tr><td>716120</td><td>UMQ / ER16</td><td>28</td><td>17</td><td>M 22x1,50</td><td>70</td></tr> <tr><td>720120</td><td>UMQ / ER20</td><td>34</td><td>19</td><td>M 25x1,50</td><td>100</td></tr> <tr><td>725120</td><td>UMQ / ER25</td><td>42</td><td>20</td><td>M 32x1,50</td><td>130</td></tr> <tr><td>732120</td><td>UMQ / ER32</td><td>50</td><td>22</td><td>M 40x1,50</td><td>170</td></tr> <tr><td>740120</td><td>UMQ / ER40</td><td>63</td><td>25</td><td>M 50x1,50</td><td>220</td></tr> <tr><td>750120</td><td>UMQ / ER50</td><td>78</td><td>35</td><td>M 64x2,00</td><td>300</td></tr> </tbody> </table>	Art.-Nr.	Typ	D	b	G	Nm max.	711120	UMQ / ER11	19	11	M 14x0,75	30	716120	UMQ / ER16	28	17	M 22x1,50	70	720120	UMQ / ER20	34	19	M 25x1,50	100	725120	UMQ / ER25	42	20	M 32x1,50	130	732120	UMQ / ER32	50	22	M 40x1,50	170	740120	UMQ / ER40	63	25	M 50x1,50	220	750120	UMQ / ER50	78	35	M 64x2,00	300
Art.-Nr.	Typ	D	b	G	Nm max.																																												
711120	UMQ / ER11	19	11	M 14x0,75	30																																												
716120	UMQ / ER16	28	17	M 22x1,50	70																																												
720120	UMQ / ER20	34	19	M 25x1,50	100																																												
725120	UMQ / ER25	42	20	M 32x1,50	130																																												
732120	UMQ / ER32	50	22	M 40x1,50	170																																												
740120	UMQ / ER40	63	25	M 50x1,50	220																																												
750120	UMQ / ER50	78	35	M 64x2,00	300																																												
<p>Spannmutter gleitgelagert DIN 6499 Clamping nut friction bearing DIN 6499</p> 	<table border="1"> <thead> <tr> <th>Art.-Nr.</th> <th>Typ</th> <th>D</th> <th>b</th> <th>G</th> <th>Nm max.</th> </tr> </thead> <tbody> <tr><td>716123</td><td>GMG / ER16</td><td>28</td><td>18</td><td>M 22x1,50</td><td>70</td></tr> <tr><td>720123</td><td>GMG / ER20</td><td>34</td><td>20</td><td>M 25x1,50</td><td>100</td></tr> <tr><td>725123</td><td>GMG / ER25</td><td>42</td><td>20</td><td>M 32x1,50</td><td>130</td></tr> <tr><td>732123</td><td>GMG / ER32</td><td>50</td><td>23</td><td>M 40x1,50</td><td>170</td></tr> <tr><td>740123</td><td>GMG / ER40</td><td>63</td><td>26</td><td>M 50x1,50</td><td>220</td></tr> </tbody> </table>	Art.-Nr.	Typ	D	b	G	Nm max.	716123	GMG / ER16	28	18	M 22x1,50	70	720123	GMG / ER20	34	20	M 25x1,50	100	725123	GMG / ER25	42	20	M 32x1,50	130	732123	GMG / ER32	50	23	M 40x1,50	170	740123	GMG / ER40	63	26	M 50x1,50	220												
Art.-Nr.	Typ	D	b	G	Nm max.																																												
716123	GMG / ER16	28	18	M 22x1,50	70																																												
720123	GMG / ER20	34	20	M 25x1,50	100																																												
725123	GMG / ER25	42	20	M 32x1,50	130																																												
732123	GMG / ER32	50	23	M 40x1,50	170																																												
740123	GMG / ER40	63	26	M 50x1,50	220																																												
<p>Spannmutter gleitgelagert DIN 6499 für Dichtscheiben Clamping nut friction bearing DIN 6499 for sealing disc</p> 	<table border="1"> <thead> <tr> <th>Art.-Nr.</th> <th>Typ</th> <th>D</th> <th>b</th> <th>G</th> <th>Nm max.</th> </tr> </thead> <tbody> <tr><td>716124</td><td>GMGC / ER16</td><td>28</td><td>23</td><td>M 22x1,50</td><td>70</td></tr> <tr><td>720124</td><td>GMGC / ER20</td><td>34</td><td>25</td><td>M 25x1,50</td><td>100</td></tr> <tr><td>725124</td><td>GMGC / ER25</td><td>42</td><td>26</td><td>M 32x1,50</td><td>130</td></tr> <tr><td>732124</td><td>GMGC / ER32</td><td>50</td><td>28</td><td>M 40x1,50</td><td>170</td></tr> <tr><td>740124</td><td>GMGC / ER40</td><td>63</td><td>31</td><td>M 50x1,50</td><td>220</td></tr> </tbody> </table>	Art.-Nr.	Typ	D	b	G	Nm max.	716124	GMGC / ER16	28	23	M 22x1,50	70	720124	GMGC / ER20	34	25	M 25x1,50	100	725124	GMGC / ER25	42	26	M 32x1,50	130	732124	GMGC / ER32	50	28	M 40x1,50	170	740124	GMGC / ER40	63	31	M 50x1,50	220												
Art.-Nr.	Typ	D	b	G	Nm max.																																												
716124	GMGC / ER16	28	23	M 22x1,50	70																																												
720124	GMGC / ER20	34	25	M 25x1,50	100																																												
725124	GMGC / ER25	42	26	M 32x1,50	130																																												
732124	GMGC / ER32	50	28	M 40x1,50	170																																												
740124	GMGC / ER40	63	31	M 50x1,50	220																																												
<p>Spannmutter DIN 6388 Clamping nut DIN 6388</p> 	<table border="1"> <thead> <tr> <th>Art.-Nr.</th> <th>Typ</th> <th>D</th> <th>b</th> <th>G</th> <th>Nm max.</th> </tr> </thead> <tbody> <tr><td>816123</td><td>OZ 16</td><td>43</td><td>24</td><td>M 33x1,50</td><td>130</td></tr> <tr><td>825123</td><td>OZ 25</td><td>60</td><td>30</td><td>M 48x2,00</td><td>200</td></tr> <tr><td>832123</td><td>OZ 32</td><td>72</td><td>34</td><td>M 60x2,50</td><td>220</td></tr> <tr><td>840123</td><td>OZ 40</td><td>85</td><td>37</td><td>M 68x2,50</td><td>270</td></tr> </tbody> </table>	Art.-Nr.	Typ	D	b	G	Nm max.	816123	OZ 16	43	24	M 33x1,50	130	825123	OZ 25	60	30	M 48x2,00	200	832123	OZ 32	72	34	M 60x2,50	220	840123	OZ 40	85	37	M 68x2,50	270																		
Art.-Nr.	Typ	D	b	G	Nm max.																																												
816123	OZ 16	43	24	M 33x1,50	130																																												
825123	OZ 25	60	30	M 48x2,00	200																																												
832123	OZ 32	72	34	M 60x2,50	220																																												
840123	OZ 40	85	37	M 68x2,50	270																																												
<p>Spannmutter DIN 6388 für Dichtscheiben Clamping nut DIN 6388 for sealing disc</p> 	<table border="1"> <thead> <tr> <th>Art.-Nr.</th> <th>Typ</th> <th>D</th> <th>b</th> <th>G</th> <th>Nm max.</th> </tr> </thead> <tbody> <tr><td>816124</td><td>OZC 16</td><td>43</td><td>29</td><td>M 33x1,50</td><td>130</td></tr> <tr><td>825124</td><td>OZC 25</td><td>60</td><td>35</td><td>M 48x2,00</td><td>200</td></tr> <tr><td>832124</td><td>OZC 32</td><td>72</td><td>38</td><td>M 60x2,50</td><td>220</td></tr> </tbody> </table> <p>Dichtscheiben für OZC16 DS/ER25, für OZC32 DS/ER40 einsetzen Sealing disc for OZC16 DS&ER25, for OZC32 DS/ER40 must be used</p>	Art.-Nr.	Typ	D	b	G	Nm max.	816124	OZC 16	43	29	M 33x1,50	130	825124	OZC 25	60	35	M 48x2,00	200	832124	OZC 32	72	38	M 60x2,50	220																								
Art.-Nr.	Typ	D	b	G	Nm max.																																												
816124	OZC 16	43	29	M 33x1,50	130																																												
825124	OZC 25	60	35	M 48x2,00	200																																												
832124	OZC 32	72	38	M 60x2,50	220																																												
<p>Spannmutter Mini Clamping nut Mini</p> 	<table border="1"> <thead> <tr> <th>Art.-Nr.</th> <th>Typ</th> <th>D</th> <th>b</th> <th>G</th> <th>Nm max.</th> </tr> </thead> <tbody> <tr><td>908100</td><td>ER - 8M</td><td>12</td><td>11</td><td>M 10x0,75</td><td>6</td></tr> <tr><td>911100</td><td>ER - 11M</td><td>16</td><td>11</td><td>M 13x1,00</td><td>20</td></tr> <tr><td>916100</td><td>ER - 16M</td><td>22</td><td>17</td><td>M 19x1,00</td><td>30</td></tr> <tr><td>920100</td><td>ER - 20M</td><td>28</td><td>19</td><td>M 24x1,00</td><td>35</td></tr> <tr><td>925100</td><td>ER - 25M</td><td>35</td><td>20</td><td>M 30x1,00</td><td>40</td></tr> </tbody> </table>	Art.-Nr.	Typ	D	b	G	Nm max.	908100	ER - 8M	12	11	M 10x0,75	6	911100	ER - 11M	16	11	M 13x1,00	20	916100	ER - 16M	22	17	M 19x1,00	30	920100	ER - 20M	28	19	M 24x1,00	35	925100	ER - 25M	35	20	M 30x1,00	40												
Art.-Nr.	Typ	D	b	G	Nm max.																																												
908100	ER - 8M	12	11	M 10x0,75	6																																												
911100	ER - 11M	16	11	M 13x1,00	20																																												
916100	ER - 16M	22	17	M 19x1,00	30																																												
920100	ER - 20M	28	19	M 24x1,00	35																																												
925100	ER - 25M	35	20	M 30x1,00	40																																												
<p>Dichtscheiben Sealing disc</p> 	<table border="1"> <thead> <tr> <th>Art.-Nr.</th> <th>Typ</th> <th>D</th> <th>b</th> <th>d1</th> </tr> </thead> <tbody> <tr><td>316...</td><td>DS / ER16</td><td>13,0</td><td>4</td><td>316050 - 316100</td></tr> <tr><td>320...</td><td>DS / ER20</td><td>16,0</td><td>4</td><td>320050 - 320130</td></tr> <tr><td>325...</td><td>DS / ER25</td><td>21,0</td><td>4</td><td>325050 - 325160</td></tr> <tr><td>332...</td><td>DS / ER32</td><td>27,0</td><td>4</td><td>332050 - 332200</td></tr> <tr><td>340...</td><td>DS / ER40</td><td>33,5</td><td>4</td><td>340050 - 340260</td></tr> <tr><td>350...</td><td>DS / OZ25</td><td>31,0</td><td>4</td><td>350050 - 350250</td></tr> </tbody> </table> <p>Kühlmitteldruck min. 5 bar - max. 100 bar Coolant pressure min. 5 bar - max. 100 bar</p>	Art.-Nr.	Typ	D	b	d1	316...	DS / ER16	13,0	4	316050 - 316100	320...	DS / ER20	16,0	4	320050 - 320130	325...	DS / ER25	21,0	4	325050 - 325160	332...	DS / ER32	27,0	4	332050 - 332200	340...	DS / ER40	33,5	4	340050 - 340260	350...	DS / OZ25	31,0	4	350050 - 350250													
Art.-Nr.	Typ	D	b	d1																																													
316...	DS / ER16	13,0	4	316050 - 316100																																													
320...	DS / ER20	16,0	4	320050 - 320130																																													
325...	DS / ER25	21,0	4	325050 - 325160																																													
332...	DS / ER32	27,0	4	332050 - 332200																																													
340...	DS / ER40	33,5	4	340050 - 340260																																													
350...	DS / OZ25	31,0	4	350050 - 350250																																													

Typ TS
 Presetting equipment TOOLSET



Typ TSO
 Optikversion mit Durchlichtprojektor 100/20 fach,
 mit drehbarem Fadenkreuz
 Optical type with trans-illumination projector 100/20x enlarge-
 ment with rotatable crosshairs



Art.-Nr.	Typ	SK	Xd	Z	Gewicht	Art.-Nr.	Typ	SK	Xd	Z	Gewicht
107410	TS 240	40	260	330	45 kg	118410	TSO 240	40	220	310	50 kg
108410	TS 250	50	260	330	45 kg	119410	TSO 250	50	220	320	50 kg
109410	TS 350	50	360	430	55 kg	120410	TSO 350	50	320	420	60 kg
121410	Drucker für Toolset / Printer for Toolset					121410	Drucker für Toolset / Printer for Toolset				

TOOLSET - Reduktionen
 TOOLSET - Reductions



TOOLFIX - Werkzeugmontagegerät
 TOOLFIX - Mounting equipment



Art.-Nr.	Typ	SK	VDI	HSK	Art.-Nr.	Typ	SK	VDI	HSK
234410	SK40xSK30	40			250410	SK 30	30		
238410	SK50xSK30	50			251410	SK 40	40		
236410	SK50xSK40	50			252410	SK 50	50		
226410	SK40xVDI20	40	20		253410	HSK-A40			A40
227410	SK40xVDI25	40	25		254410	HSK-E40			E40
228410	SK40xVDI30	40	30		255410	HSK-A50			A50
231410	SK50xVDI40	50	40		256410	HSK-E50			E50
232410	SK50xVDI50	50	50		257410	HSK-A63			A63
239410	SK40xHSK 32	40		A+E32	258410	HSK-E63			E63
240410	SK40xHSK 40	40		A+E40	259410	VDI-20		20	
241410	SK40xHSK 50	40		A+E50	260410	VDI-30		30	
242410	SK40xHSK 63	40		A+E63	261410	VDI-40		40	
246410	SK50xHSK 63	50		A+E63					
248410	SK50xHSK100	50		A100					

TOOLFIX TURN



Zusätzlich zu den gewohnten 8x45° Schwenk-funktionen kann diese Ausführung, für Messerköpfe usw. zum übersichtlichen Schneidplattenwechsel, radial gedreht werden und 12-fach (alle 30°) indexiert werden.

In addition to the standard 8x45° swivelling capacity Toolfix Turn can be turned radially in case of using cutter heads etc. for changing the cutting inserts in an easier way, and it can be indexed 12x (every 30°).

Art.-Nr.	Typ	Art.-Nr.	Typ
33040	VARIO Turnadapter SK40	32040	monoblock SK40
33050	VARIO Turnadapter SK50	32050	monoblock SK50
33263	VARIO Turnadapter HSK-A 63	32263	monoblock HSK-A 63
33210	VARIO Turnadapter HSK-A100	32210	monoblock HSK-A100

TOOLFIX VARIO Adaptersystem



VARIO ist die Version mit Schnellwechselverschluss zum Auswechseln von verschiedenen Werkzeugadaptoren. Die VARIO-Version bietet Anwendern von verschiedenen Werkzeugaufnahmen die Möglichkeit verschiedene Adapterformen auf einem Basiskörper zu verwenden.

VARIO is a version with quick change lock for changing different tool adapters. The VARIO-version makes possible to use different forms of adapters on the same base-body for users with different toolholders.

Art.-Nr.	Typ	SK	VDI	HSK	Art.-Nr.	Typ	SK	VDI	HSK
31000	Toolfix Vario				31232	VARIO-Adapter			A 32
	Basiskörper				31240	VARIO-Adapter			A 40
31030	VARIO-Adapter	30			31250	VARIO-Adapter			A 50
31040	VARIO-Adapter	40			31263	VARIO-Adapter			A 63
31050	VARIO-Adapter	50			31280	VARIO-Adapter			A 80
					31210	VARIO-Adapter			A100
31116	VARIO-Adapter		16						
31120	VARIO-Adapter		20		31632	VARIO-Adapter			E 32
31125	VARIO-Adapter		25		31640	VARIO-Adapter			E 40
31130	VARIO-Adapter		30		31650	VARIO-Adapter			E 50
31140	VARIO-Adapter		40		31663	VARIO-Adapter			E 63
31150	VARIO-Adapter		50						

1. Angebot – Auftrag

Unsere Angebote in jeder Form, auch solche durch Vertreter, sind freibleibend. Aufträge sind nur mit unserer Zustimmung widerruflich.

2. Preise

Preise verstehen sich in EUR.

Rechnungsmindestbetrag EUR 50.-

Die Preise gelten ab Werk, ausschließlich Verpackung und Umsatzsteuer. Wir behalten uns vor, die am Tage der Lieferung gültigen Preise zu berechnen. Die Rechnung ersetzt bei sofortiger Lieferung die Auftragsbestätigung.

3. Lieferzeit

Die Lieferzeit beginnt erst nach völliger Klärung des Auftrages für beide Teile und nach unserer schriftlichen Auftragsbestätigung.

Teillieferungen sind zulässig, auch wenn dadurch dem Empfänger höhere Versandkosten entstehen. Unvorhergesehene Lieferschwierigkeiten, die außerhalb unseres Willens als Lieferer liegen, z.B. durch höhere Gewalt, Betriebsstörung, Ausschubarbeit, Verspätung von Vorlieferanten, Streik u.a. berechtigen uns zu angemessener Verlängerung der Lieferzeit, auch wenn sie erst während eines Lieferverzuges eintreten.

Nichteinhaltung der Zahlungsbedingungen, nachträglich festgestellte Kreditgefährdung oder unzumutbare Erschwerung der Lieferung berechtigen uns zum ganzen oder teilweisen Rücktritt. Schadensersatzansprüche des Bestellers sind dann ausgeschlossen.

4. Liefermenge

Bei Sonderanfertigungen ist Mehr- oder Minderlieferung bis zu 10% der bestellten Menge als branchenüblich zulässig.

5. Verpackung

Die Verpackungsart wählen wir nach eigener Beurteilung.

6. Versand

Alle Sendungen laufen auf Gefahr des Bestellers, auch bei frachtfreier Lieferung oder Überbringung. Die Gefahr geht mit der Warenübergabe an einen Spediteur oder Frachtführer, spätestens jedoch mit Verlassen des Werkes, auf den Besteller über. Wir haften lediglich für eine ordnungsgemäße Abfertigung durch unsere Mitarbeiter.

7. Zahlung

Die Zahlung ist innerhalb folgender Fristen fällig:

10 Tage 2% Skonto,

30 Tage netto,

jeweils ab Rechnungsdatum bei uns eingehend.

Skontierung ist nur zulässig, wenn alle fälligen Rechnungen bezahlt sind.

Wechselspesen gehen zu Lasten des Bestellers und sind sofort netto zahlbar. Zielüberschreitungen berechtigen zu Verzugszinsen in Höhe der banküblichen Sollzinsen. Zahlungsverzug oder Unsicherheit der Vermögenslage haben die Fälligkeit sämtlicher Forderungen zur Folge. Die Zurückhaltung oder Aufrechnung fälliger Zahlungen durch den Besteller wegen irgendwelcher Gegenansprüche sind ausgeschlossen.

8. Mängelhaftung

Fehlerhafte Ware wird von uns so schnell wie möglich ersetzt oder nachgebessert. Bei Anfertigung nach Zeichnung des Bestellers haften wir nur für zeichnungsgerechte Ausführung.

Weitere Forderungen und Schadensersatzansprüche des Bestellers wegen Nichterfüllung, Fahrlässigkeit und anderer Gründe, auch aus mittelbarem Schaden und während eines Verzuges, sind ausdrücklich ausgeschlossen.

9. Eigentumsvorbehalt

Gelieferte Waren bleiben unser Eigentum bis unsere sämtlichen Ansprüche vom Besteller erfüllt sind. Der Besteller darf seine Vertragsrechte nur mit unserer Zustimmung auf Dritte übertragen.

Bei Verarbeitung, Verbindung und/oder Vermischung der Vorbehaltsware mit anderen, uns nicht gehörenden Waren, steht uns an der neuen Sache das Miteigentum im Verhältnis des Rechnungswertes der Vorbehaltsware zum Rechnungswert der anderen Waren, einschließlich der Aufwendungen für die Verarbeitung (Verbindung, Vermischung) zu. Im übrigen gilt die Verarbeitung in jedem Fall als für uns erfolgt, so daß sich der Eigentumsvorbehalt somit auf die verarbeitete (verbundene, vermischte) Ware, gegebenfalls auf den neuen Gegenstand, erstreckt.

Unsere Rechte aus einfachem, verlängertem und erweitertem Eigentumsvorbehalt gehen auch nicht durch Wechsel-Scheck-Zahlungsweise des Schuldners unter. Unsere Eigentumsvorbehalte bleiben so lange bestehen, bis wir in diesem Fall von unserer Wechsel-Ausstellerhaftung oder Haftung aus Wechselbürgschaft bzw. Indossament befreit sind.

10. Erfüllungsort und Gerichtsstand

Erfüllungsort für die Lieferung ist der Ort unseres Lieferwerkes. Erfüllungsort für die Zahlung ist Dusslingen.

Gerichtsstand für Streitigkeiten aus Verträgen mit Vollkaufleuten, juristischen Personen des öffentlichen Rechts oder öffentlich-rechtlichen Sondervermögen ist Tübingen. Wir sind auch berechtigt, am Hauptsitz des Bestellers zu klagen.

Der Liefervertrag bleibt auch bei Unwirksamkeit einzelner Bestimmungen im übrigen verbindlich.

11. Einkaufsbedingungen des Bestellers

sind für uns nur soweit gültig, als wir ihre Annahme ausdrücklich schriftlich bestätigt haben.

Den Angeboten, Auftragsbestätigungen und Lieferungen über Sonder-Werkzeuge und -Vorrichtungen sowie über Lohnarbeiten liegen die »Allgemeinen Bedingungen für Lieferung von Maschinen« des VDMA zugrunde.

02/2008

**Werkzeughalter-System für Ein- und Mehrspindel-
Drehautomaten schnellwechselbar und voreinstellbar**
Toolholders system for one and multiple spindle lathes



45°-Einstechschieber mit zyl. Schaft
45° Pushover recessing box

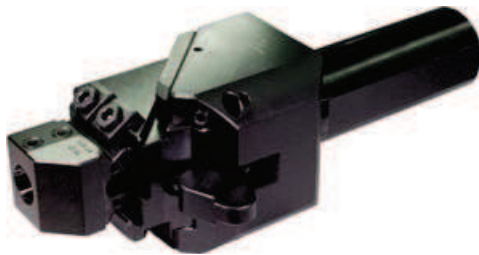

90°-Einstechschieber mit zyl. Schaft
90° Pushover recessing box



Überdrehwerkzeughalter
Adjustable overhead turning attachment



90°-Einstechschieber
90° Arresting resetting head



Seitenschlitten-Werkzeughalter AWN
Vertical dovetail form toolholder



Abstechmeisselhalter
Parting off toolholder



Seitenschlitten-Werkzeughalter INDEX MS25
Horizontal dovetail form toolholder INDEX MS25

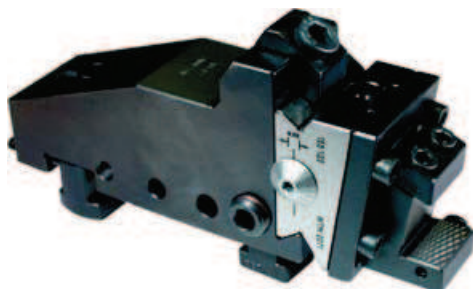

Bohrerhalter System mini-fix
Drill and cutter holder system mini-fix



Werkzeughalter für Bohrungsbearbeitung
Boring head toolholder



Schnellbohrspindel System mini-fix
High speed drilling spindle system mini-fix





zürn

Werkzeug-Systeme Spannwerkzeuge

Tool systems
Holding tools

