

PARAT 

GENERAL CATALOGUE

2008/2009



ROLLER CASES

PARATOOL

p. 4-5



**CARGO /
CLASSIC**
p. 6-9

TOOL CASES

CARGO

p. 12-16



CLASSIC
p. 18-20

LEATHER TOOL CASES

TOP-LINE

p. 28-34



NEW CLASSIC
p. 36-41

TOOL POUCHES

TOOL ROLLS

p. 42-44

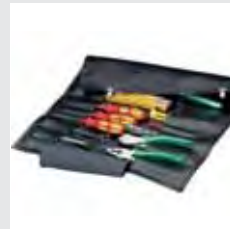
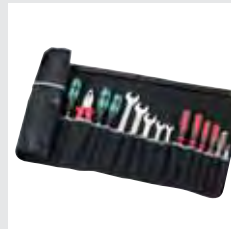

BACKPACK
p. 44

SPECIAL CASES

PROFI-LINE

p. 50-53

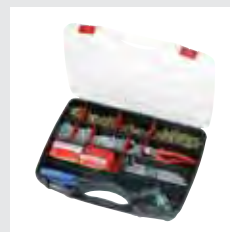

PARAPRO
p. 54-59

ILLUMINANTS

**PARAT
X-TREME**

p. 62-65

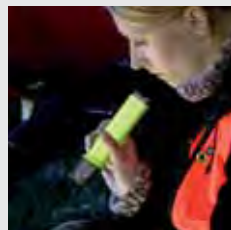

LIGHT STICKS
p. 66-69



TOP-LINE

p. 10-11



SILVER

p. 22-26



BASIC

p. 42-44



BELT POUCHES

p. 46-49



PILOT

p. 60-61

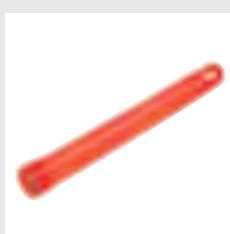

INFO

p. 70-73





PARAT®

Your authentic partner

PARAT is the specialist for high-quality moulded cases and leather cases for tools, as well as for notebook cases and transport systems for mobile IT-application. PARAT also stands for high quality and modern manufacturing-know-how. Motivated and qualified employees ensure a high level of flexibility in production. PARAT WERK has produced professional tool cases and tool bags for trade and industry for three generations.

Thereby, the customers' requests are definitely of particular interest. They define the standards concerning manufacturing, handling and long-life cycle, which have to be recently redefined by continuous product-engineering. PARAT is the synonym for perfect combination of innovative technic and traditional high class workmanship.

PARAT products are first-class products in their segment. The PARAT moulded tool and leather cases rank among the top-selling ones in Europe. More than 60 years experience in manufacturing tool storage systems provide the development of especially high-quality tool cases with innovative detail solutions.

The company

PARAT-Werk Schönenbach GmbH & Co. KG was founded in Remscheid in 1945 by Heinz Schönenbach and is still family-owned. The experiences PARAT gained in the case production by processing synthetics, leather and plastics, resulted in the formation of PARAT Automotive. This independent company is a certified supplier of the automotive industry. Amongst others PARAT Automotive develops and manufactures convertible roof systems with the latest technologies. The experience with the large-volume production for the automotive industry also goes into the further development of the company's core products. Altogether, PARAT employs approximately 900 people at seven locations.

The products

PARAT has a worldwide valid quality management system according to DIN EN ISO 9001, QS 9000, VDA 6.1, as well as the environment management system DIN EN ISO 14001. The constant quality is an essential part of the company's philosophy. The ambition is to hold the high quality level and improve it continuously.





Made in Germany

Since autumn 2007 the PARAT moulded tool cases are marked with "Made in Germany". All PARAT moulded tool cases are produced in our factory in Neureichenau/Germany. The leather tool cases are produced in our factory in Romania.



Exceptionally sturdy MIL

The new special cases of the PARAPRO range are exceptionally sturdy and indestructible. They comply with the high requirements of the military standard MIL. They are indestructible at temperatures between -30°C and +90°C.



Double-walled

Side-walls made of double-walled HDPE-plastic provide hold and stability for a lot of models of the Top-Line and New Classic leather tool cases. The dimensionally stable plastic sides are wearless and moisture resistant. In conjunction with aluminium angles in all four edges they assure a considerably longer life time of the leather tool cases.

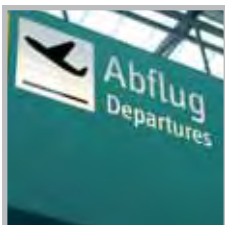

Airworthy

Most of the PARAT moulded tool cases are equipped with the airplane sign. It stands for "airworthy". These moulded tool cases are so robust that they survive the harsh baggage handling at airports without any difficulties. This requirement gets more and more important, not only for worldwide travelling service technicians.



Wheeled

Roller cases set the trend. The integrated trolley relieves the user, because it enables him a comfortable transport by rolling the case to the field of application instead of carrying it. The model with wheels helps to reduce back problems and as a result loss of working hours.



Waterproof

PARAPRO cases and PARAT X-treme safety lights are not only moisture resistant, but also 100 % waterproof, airtight and dustproof according to IP 67. Therefore, damageable contents inside the cases are effectively protected and the function of the lights is guaranteed.



PARATOOL

The multi-functional tool

The PARATOOL mobile service-station features an integrated system of wheels and telescopic handle. It can be wheeled across the floor or used to carry loads, and the storage surfaces can be raised to a convenient working height on site. The case offers ample space for tools as well as for bottles and cans which must be carried in a vertical position.

The handle can be pulled out to three different positions, up to a maximum height of 980 mm. The rubber coated wheels have a diameter of 130 mm and are designed for easy running, even on rough surface areas. The case trolley incorporates a small parts magazine with cover.



Standard PARATOOL features at a glance:

- ergonomic working with a convenient average working level of 600 mm
- inner shell cover which can be used as a shelf for tools and materials
- carrying and lifting function with one-hand operation
- small parts magazine in trolley
- sturdy shells made of high-strength plastic Xenoy = airworthy
- case designed to carry up to 40 kg plus load on trolley
- efficient use of space, even for large parts
- PARAT barrel locks
- sturdy Con-Pearl® tool boards

 = airworthy

 = with wheels

 = Made in Germany

PARAT 

PARATOOL

PARATOOL

- with 3 CP-7 holders and inside tray
- 1 tool board and
- 1 cover plate with
- 1 CP-7 tool holder, ø 11 mm
- 1 CP-7 tool holder, ø 15 mm
- 1 CP-7 tool holder, ø 26 mm
- 1 inside tray with cover plate
- height 22-54 mm, 4 compartments
- 1 document compartment in lid

Art. No

2093 . 000 - 171



465 x 210 x 355 mm



~ 8.200 g



Plastic (Xenoy)

COLOR

black

SPECIALS



PARATOOL

- with 4 CP-7 tool holders and inside tray
- 2 tool boards with
- 2 CP-7 tool holders, ø 11 mm
- 1 CP-7 tool holder, ø 15 mm
- 1 CP-7 tool holder, ø 26 mm
- 1 inside tray with cover plate
- height 22-54 mm, 4 compartments
- 1 document compartment in lid
- 1 PARATOOL shelf

Art. No

2094 . 000 - 171



465 x 210 x 355 mm



~ 8.900 g



Plastic (Xenoy)

COLOR

black

SPECIALS



PARATOOL

- with push-in compartments and inside tray
- 1 tool board with
- 25 push-in compartments
- 1 keep-safe compartment, 400 mm
- 1 tool board with
- 15 push-in compartments
- 1 keep-safe compartment, 400 mm
- 1 inside tray with cover plate
- height 22-54 mm, 4 compartments
- 1 PARATOOL shelf

Art. No

2097 . 000 - 171



465 x 210 x 355 mm



~ 8.300 g



Plastic (Xenoy)

COLOR

black

SPECIALS



Stage 1 – the classic tool case

Stage 2 – pull out the telescopic handle and roll away

Stage 3 – lift the case and load the trolley

Stage 4 – open the case and your tools are right where you need them - the telescoped trolley ensures high stability





CARGO/CLASSIC

The latest generation of roller cases

The newly developed PARAT Cargo and Classic roller system sets new standards, combining minimum space requirements with maximum sturdiness, convenience and elegance. The extra-wide four-stage telescopic handle made of powder-coated aluminium with a height of 950 to 1.150 mm has ideal size for ergonomic work.

Large rubber-coated wheels with sliding bearings and the wide wheelbase make the system easy to handle. In addition they have a firm stand and are an ideal solution for work on site. Based on the approved PARAT Cargo and Classic ranges, the new tool cases are fully integrated into the PARAT range, offering all the usual performance features and equipment combined with enhanced mobility and convenience.



CARGO/CLASSIC roller cases features at a glance:

- 4-stage telescopic handle 950 - 1.150 mm, extra-wide, powder-coated
- for pushing or pulling
- large, rubber-coated wheels with sliding bearings
- wide wheelbase, stable
- robust shells, suitable for air travel made of X-ABS
- maximum load 40 kg, double aluminium frame
- new developed ratched locks with safety latch
- sturdy Con-Pearl® tool boards
- individually adaptable CP-7 tool holders or stitched compartments

 = airworthy

 = with wheels

 = Made in Germany

PARAT 

CARGO/CLASSIC ROLLER CASES

CARGO roller case

- the King-Size case with wheels**
 2 tool boards and
 1 cover plate with
 2 CP-7 tool holders, ø 11 mm
 1 CP-7 tool holder, ø 15 mm
 1 CP-7 tool holder, ø 26 mm
 1 bottom tray with cover plate
 height 88 mm, with variable
 subdivisions
 1 document compartment in lid

Art.No

99 . 500 - 171



470 x 210 x 355 mm



~ 6.600 g



X-ABS-Plastic



black



CLASSIC roller case

- with wheels**
 1 tool board with 25 push-in
 compartments
 1 keep-safe compartment, 400 mm
 1 tool board with 10 push-in
 compartments
 1 cover plate with 15 push-in
 compartments
 1 keep-safe compartment, 400 mm
 1 bottom tray with cover plate
 height 58 mm, with variable
 subdivisions
 1 document compartment in lid

Art.No

481 . 500 - 171



460 x 190 x 310 mm



~ 6.200 g



X-ABS-Plastic



black



CLASSIC roller case

- the King-Size case with wheels**
 1 tool board with 25 push-in comp.
 1 keep-safe compartment, 400 mm
 1 tool board with 10 push-in comp.
 1 cover plate with 15 push-in comp.
 1 keep-safe compartment, 400 mm
 1 bottom tray with cover plate
 height 88 mm, with variable
 subdivisions
 1 document compartment in lid
 1 lockable lid holder

Art.No

489 . 500 - 171



470 x 210 x 360 mm



~ 6.800 g



X-ABS-Plastic



black



CLASSIC roller case

- the King-Size-Plus case with wheels**
 1 tool board with 31 push-in comp.
 1 tool board with 12 push-in comp.
 1 cover plate with 19 push-in comp.
 1 keep-safe compartment, 530 mm
 1 bottom tray with
 1 compartment 560x90 (67)x223 mm
 with variable subdivisions
 1 compartment 540x57x140 mm
 loops for spirit level
 1 document compartment in lid
 lockable lid holder

Art.No

489 . 600 - 171



575 x 220 x 425 mm



~ 9.200 g



X-ABS-Plastic



black



The family has been completed

The PARAT Classic roller cases

Mobile tool cases set absolutely the trend. Over the past few years the growth rates for roller cases have been far above average growth.

Back problems are one of the main reasons for absence caused by illness among field service technicians. With roller cases, back problems in consequence of carrying heavy tool cases, can be avoided or at least significantly reduced.

So far, PARAT has mainly offered roller solutions for the large cases (inside dimensions approx. 470 x 210 x 360 mm or 575 x 220 x 425 mm). These large cases are normally used for heavy loads. The most popular case size (inside dimensions approx. 460 x 190 x 310 mm) was not available with rollers up to now. However, fully loaded with tools, these cases can easily weigh between 15 and 18 kilograms.

The integration of the actual trolley system that is used for the two larger cases (489.500.171 + 489.600.171) is not possible for the smaller one (481.500.171), because the telescopic system is fixed inside the case. In view of the compact size, we would lose too much space inside the smaller case.

To avoid space problems inside the smaller Classic roller case (481.500.171) we developed a new trolley system which is mounted outside of the case. In addition a 4-section telescopic handle had to be constructed. The handle is installed in a special sleeve to allow movement and an overall length of at least 950 mm. This height is essential for easy use.

A sturdy telescopic handle is essential as tool cases are often used 220 to 240 days per year and not only 2 to 3 weeks yearly, as suitcases. To live up to this charge the roller cases are equipped with an extra-wide telescopic handle made of powder-coated aluminium.

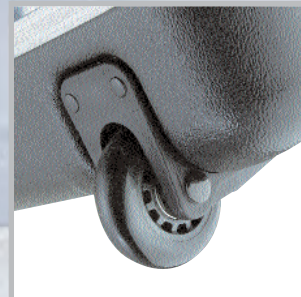

Due to this construction the case is rolled along its long side - as all of our roller cases - to avoid a change of position. As a result tools have not to be sorted into their compartments when opening the case. Large rubber-coated inline wheels with wide wheel base facilitate the use and make the system sturdy.

Also the "small" Classic roller case (481.500.171) is made of robust, airtight X-ABS plastic. In combination with the especially developed double aluminium frame from PARAT, we grant a maximum load up to 40 kilos and an optimum protection of your tools.

As already known from the Classic range, also the new roller case (481.500.171) is equipped with the approved stitched compartments.

481.500.171 - standard-size

The Classic tool case 481.000.171 is still the bestseller of our standard range. We don't want to set any limits to the rollable trend, that's why we are now offering this case with the professional trolley system.

489.500.171 - King-Size

This medium-sized tool case is the first Classic roller case made by PARAT and is actually the bestseller in this product range.

489.600.171 - King-Size-Plus

This tool case with the "giant" size accommodates also bulky tools as big handsaws. Another difference to the King-Size case (489.500.171) is the plus of 20% of stitched compartments for tools.

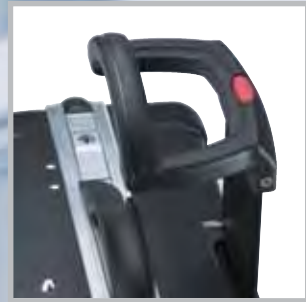

www.parat.de



TOP-LINE

Know-How

Also leather tool cases can be rolled!

High-quality Top-Line tool cases with approved interior fittings, additionally equipped with a professional wheel and telescopic handle system make transport to the building site much easier.



Top-Line roller tool cases features at a glance:

- 4-stage telescopic handle 1.020 mm
- large, rubber-coated wheels with sliding bearings
- wide wheelbase
- no loss of space inside the cases
- small extra weight
- sturdy embossed leather
- ergonomic handles for easy carrying, with grip recesses and sturdy metal handle rails
- variable locks
- strengthened by aluminium angles
- sturdy Con-Pearl® tool boards
- CP-7 tool holder system individually adaptable



= with wheels



= Made in EU

PARAT 

TOP-LINE WITH ROLLERS

Top-Line tool case

with middle wall
 Semi-fold-out front wall with
 1 CP-7 tool holder, μ 26 mm
 middle wall with
 1 CP-7 tool holder, μ 11 mm
 1 CP-7 tool holder, μ 15 mm
 rear wall with
 1 CP-7 tool holder, μ 15 mm
 Variable locks

Art. No.

17.500 - 581



450 x 190 x 340 mm



~ 4.500 g



Genuine leather, Con-Pearl®



black



Top-Line tool case

with middle wall
 Semi-fold-out front wall with
 1 CP-7 tool holder, μ 15 mm
 middle wall with
 1 CP-7 tool holder, μ 11 mm
 1 CP-7 tool holder, μ 15 mm
 Rear wall with
 1 CP-7 tool holder, μ 26 mm
 Plastic compartment with lid in bottom
 Front pouch, variable locks

Art. No.

18.500 - 581



450 x 190 x 340 mm



~ 5.600 g



Genuine leather, Con-Pearl®



black



Top-Line case with drawers

5 drawers
 Fold-out front wall
 Rear wall with
 1 CP-7 tool holder, μ 15 mm
 90 mm storage space behind drawers
 Portable carrying insert
 Compartment for small parts
 Variable locks

Art. No.

44.500 - 581



410 x 220 x 310 mm



~ 5.700 g



Genuine leather, Con-Pearl®



black





Cargo

The best in form and function!

This exclusive tool case features tailored solutions using the CP-7 organization system. Double inside frames made of solid aluminium allow a maximum load of 40 kg. Even with a heavy load, the case always lies comfortably in the hand

due to the ergonomic handle with its grip recesses. The lock has a safety latch ensuring that it can only be opened if the case is placed in the right position. The materials can be easily separated for recycling.





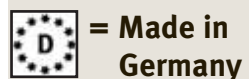
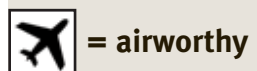

Cargo features at a glance:



- sturdy X-ABS or aluminium shells, airworthy
- ergonomic handles with grip recesses for easy carrying
- PARAT barrel locks with automatic safety latches
- 40 kg maximum load, double aluminium inside frame
- hinges with ratchet and locking mechanism
- integrated bottom studs to protect case
- sturdy Con-Pearl® tool-boards
- CP-7 tool holder system individually adaptable





CARGO







| | | |
|--|---|---|
| <p>Cargo moulded tool case</p> <p>empty - without interior fittings (look at accessories) You can fit the case out in accordance with your requirements. PARAT sales staff will be pleased to provide advice.</p> | <p>Art.No 90 . 000 - 171</p> <p>460 x 185 x 310 mm</p> <p>~ 2.700 g</p> <p>X-ABS-Plastic</p> <p>black</p> <p>SPECIALS </p> |  |
|--|---|---|

| | | |
|--|--|--|
| <p>Cargo moulded tool case</p> <p>the slim case</p> <ul style="list-style-type: none"> 1 tool board and 1 cover plate with 1 CP-7 tool holder, ø 11 mm 1 CP-7 tool holder, ø 15 mm 1 CP-7 tool holder, ø 26 mm 1 bottom tray with cover plate, height 58 mm, with variable subdivisions 1 document compartment in lid | <p>Art.No 91 . 000 - 171</p> <p>460 x 140 x 310 mm</p> <p>~ 4.500 g</p> <p>X-ABS-Plastic</p> <p>black</p> <p>SPECIALS </p> |  |
|--|--|--|

| | | |
|--|---|---|
| <p>Cargo moulded tool case</p> <p>the medium-sized case</p> <ul style="list-style-type: none"> 1 tool board and 1 cover plate with 1 CP-7 tool holder, ø 11 mm 1 CP-7 tool holder, ø 15 mm 1 CP-7 tool holder, ø 26 mm 1 bottom tray with cover plate, height 58 mm, with variable subdivisions 1 document compartment in lid | <p>Art.No 92 . 000 - 171</p> <p>460 x 185 x 310 mm</p> <p>~ 4.700 g</p> <p>X-ABS-Plastic</p> <p>black</p> <p>SPECIALS </p> |  |
|--|---|---|

| | | |
|---|---|---|
| <p>Cargo moulded tool case</p> <p>case with deep bottom tray</p> <ul style="list-style-type: none"> 1 tool board and 1 cover plate with 1 CP-7 tool holder, ø 11 mm 1 CP-7 tool holder, ø 15 mm 1 CP-7 tool holder, ø 26 mm 1 bottom tray with cover plate, height 88 mm, with variable subdivisions 1 document compartment in lid | <p>Art.No 93 . 000 - 171</p> <p>470 x 205 x 355 mm</p> <p>~ 5.700 g</p> <p>X-ABS-Plastic</p> <p>black</p> <p>SPECIALS </p> |  |
|---|---|---|

CARGO

| | | | |
|---|--|---|---|
|  | <p>94 . 000 - 171 460 x 185 x 310 mm ~ 5.200 g X-ABS-Plastic black</p>  |       | <p>Cargo moulded tool case the medium-sized case 2 tool boards and 1 cover plate with 2 CP-7 tool holders, ø 11 mm 1 CP-7 tool holder, ø 15 mm 1 CP-7 tool holder, ø 26 mm 1 bottom tray with cover plate, height 58 mm, with variable subdivisions 1 document compartment in lid</p> |
|  | <p>95 . 000 - 171 460 x 170 x 310 mm ~ 4.000 g X-ABS-Plastic black</p>  |       | <p>Cargo moulded tool case designed for opening to 180° 4 tool boards with 3 CP-7 tool holders, ø 11 mm 2 CP-7 tool holders, ø 15 mm 1 CP-7 tool holder, ø 26 mm 1 document compartment in lid</p> |
|  | <p>96 . 000 - 171 460 x 185 x 310 mm ~ 3.600 g X-ABS-Plastic black</p>  |       | <p>Cargo moulded tool case for measuring instruments 1 cover plate with 1 CP-7 tool holder, ø 26 mm, and padding with corrugated surface 1 bottom tray with pre-cut foam rubber cut spacing 17 mm, 3 layers of foam total height 70 mm 1 document compartment in lid</p> |
|  | <p>97 . 000 - 171 460 x 185 x 310 mm ~ 5.200 g X-ABS-Plastic black</p>  |       | <p>Cargo moulded tool case with combination lock 2 tool boards and 1 cover plate with 2 CP-7 tool holders, ø 11 mm 1 CP-7 tool holder, ø 15 mm 1 CP-7 tool holder, ø 26 mm 1 bottom tray with cover plate, height 58 mm, with variable subdivisions 1 document compartment in lid</p> |

CARGO







| | | | |
|---|--|---------------------------|--|
| <p>Cargo moulded tool case</p> | | <p>99 . 000 - 171</p> | |
| <p>for insulated tools 2 tool boards and 1 cover plate with 1 CP-7 tool holder, ø 15 mm 3 CP-7 tool holders, ø 26 mm 1 bottom tray with cover plate, height 58 mm, with variable subdivisions</p> | | <p>470 x 200 x 355 mm</p> | |
| | | <p>~ 5.400 g</p> | |
| | | <p>X-ABS-Plastic</p> | |
| | | <p>black</p> | |
| | | | |

| | | | |
|--|--|---------------------------|--|
| <p>Cargo moulded tool case</p> | | <p>99 . 000 - 176</p> | |
| <p>with red shells, for insulated tools 2 tool boards and 1 cover plate with 1 CP-7 tool holder, ø 15 mm 3 CP-7 tool holders, ø 26 mm 1 bottom tray with cover plate, height 58 mm, with variable subdivisions</p> | | <p>470 x 200 x 355 mm</p> | |
| | | <p>~ 5.400 g</p> | |
| | | <p>Plastic (ABS)</p> | |
| | | <p>red</p> | |
| | | | |





| | | | |
|--|--|---------------------------|--|
| <p>Cargo moulded tool case</p> | | <p>99 . 100 - 171</p> | |
| <p>the King-Size case 2 tool boards and 1 cover plate with 2 CP-7 tool holders, ø 11 mm 1 CP-7 tool holder, ø 15 mm 1 CP-7 tool holder, ø 26 mm 1 bottom tray with cover plate, height 88 mm, with variable subdivisions 1 document compartment in lid</p> | | <p>470 x 210 x 355 mm</p> | |
| | | <p>~ 5.500 g</p> | |
| | | <p>X-ABS-Plastic</p> | |
| | | <p>black</p> | |
| | | | |





| | | | |
|---|--|---------------------------|--|
| <p>Cargo moulded tool case</p> | | <p>1094 . 000 - 909</p> | |
| <p>with aluminium shells 2 tool boards and 1 cover plate with 2 CP-7 tool holders, ø 11 mm 1 CP-7 tool holder, ø 15 mm 1 CP-7 tool holder, ø 26 mm 1 bottom tray with cover plate, height 58 mm, with variable subdivisions 1 document compartment in lid</p> | | <p>470 x 190 x 355 mm</p> | |
| | | <p>~ 6.000 g</p> | |
| | | <p>painted aluminium</p> | |
| | | <p>alu nature</p> | |
| | | | |





CARGO

| | | | |
|---|---|--|---|
|  | <p>1099 . 000 - 909 470 x 190 x 355 mm ~ 5.900 g painted aluminium alu nature</p>  | <p>Art. No.</p>    <p>COLOR</p>  | <p>Cargo moulded tool case with aluminium shells, for insulated tools 2 tool boards and 1 cover plate with 1 CP-7 tool holder, ø 15 mm 3 CP-7 tool holders, ø 26 mm 1 bottom tray with cover plate, height 58 mm, with variable subdivisions</p> |
|---|---|--|---|

ACCESSORIES

| | | | |
|--|--|---|---|
|  | <p>491 . 000 - 551 440 x 160 mm ~ 360 g Con-Pearl® black</p> | <p>Art. No.</p>    <p>COLOR</p> | <p>CP-7 tool board 2-sided 1 CP-7 tool holder for tools up to ø 11 mm 1 CP-7 tool holder for tools up to ø 15 mm</p> |
|--|--|---|---|

| | | | |
|---|--|---|--|
|  | <p>494 . 000 - 551 440 x 185 mm ~ 340 g Con-Pearl® black</p> | <p>Art. No.</p>    <p>COLOR</p> | <p>CP-7 tool board 1-sided 1 CP-7 tool holder for tools up to ø 11 mm</p> |
|---|--|---|--|

| | | | |
|---|--|---|---|
|  | <p>498 . 012 - 161 420 x 275 x 58 mm ~ 1.380 g Plastic (ABS) black</p> | <p>Art. No.</p>    <p>COLOR</p> | <p>Bottom tray with variable subdivisions 1 long divider 3 short dividers 1 flush cover plate with 1 CP-7 tool holder for tools up to ø 26 mm for cases with heights up to 310 mm (except 95.000-171 and 96.000-171)</p> |
|---|--|---|---|

Mobile office solutions



Where do you want to work today?

Mobile office solutions by PARAT® offer various applications of a complete traditional office but on a minimum space. Whether you need a hardcase in aluminium design, a pilot trolley or a comfortable travelling bag: our office solutions offer a safe place for laptop, printer, projector and various accessories.

Service, sales or training?

PARAT® supports the comfortable use of IT-equipment independent of time and place. Numerous customers like BSH, Bosch Siemens Hausgeräte, Electrolux, TÜV Rheinland, Bauknecht/Whirlpool, Vaillant, R+V, AXA etc. trust in products made by PARAT®.

Professional production, high manufacturing quality and various product features up to individual customized solutions guarantee the protection and mobility of your data: anytime and anywhere.





Classic

No compromises!

These sturdy cases made of high-quality plastic X-ABS, have a new design with high strength and a carrying capacity of up to 30 kg. The ergonomic handle with its grip recesses means that the case lies comfortably in the hand.

The hinge is equipped with a ratchet and locking mechanism which holds the lid in the required position when open.

Classic features at a glance:

- sturdy X-ABS or aluminium shells, airworthy
- 30 kg maximum load; double aluminium frame
- ergonomic handles with grip recesses for easy carrying
- PARAT barrel locks
- hinges with ratchet and locking mechanism
- sturdy Con-Pearl® tool boards
- integrated bottom studs to protect case



 = airworthy

 = Made in Germany

PARAT 

CLASSIC

Classic moulded tool case

empty - without interior fittings (look at accessories)

You can fit the case out in accordance with your requirements. PARAT sales staff will be pleased to provide advice.

Art.No

480 . 000 - 171



460 x 190 x 310 mm



~ 2.500 g



X-ABS-Plastic

COLOR

black

SPECIALS



Classic moulded tool case

the classical case

- 1 tool board with 25 push-in compartments
- 1 keep-safe compartment, 400 mm
- 1 tool board with 10 push-in compartments
- 1 cover plate with 15 push-in compartments
- 1 keep-safe compartment, 400 mm
- 1 bottom tray with cover plate, height 58 mm, with variable subdivisions
- 1 document compartment in lid

Art.No

481 . 000 - 171



460 x 190 x 310 mm



~ 5.100 g



X-ABS-Plastic

COLOR

black

SPECIALS



Classic moulded tool case

with aluminium shells

- 1 tool board with 25 push-in compartments
- 1 keep-safe compartment, 400 mm
- 1 tool board with 10 push-in compartments
- 1 cover plate with 15 push-in compartments
- 1 keep-safe compartment, 400 mm
- 1 bottom tray with cover plate, height 58 mm, with variable subdivisions
- 1 document compartment in lid

Art.No

481 . 000 - 909



460 x 170 x 310 mm



~ 5.200 g



Anodized aluminium

COLOR

alu nature

SPECIALS



Classic moulded tool case

the slim case

- 1 tool board with 13 push-in compartments
- 1 cover plate with 15 push-in compartments
- 1 keep-safe compartment, 400 mm
- 1 bottom tray with cover plate, height 58 mm, with variable subdivisions
- 1 document compartment in lid
- Metal hinges, lid holders

Art.No

484 . 000 - 171



460 x 120 x 310 mm



~ 4.100 g



X-ABS-Plastic









COLOR









black









SPECIALS



CLASSIC

| | | | |
|---|---|---|---|
|  | <p>488 . 000 - 171 470 x 200 x 360 mm ~ 5.000 g X-ABS-Plastic black</p>  |       | <p>Classic moulded tool case with deep bottom tray 1 tool board with 25 push-in compartments 1 keep-safe compartment, 400 mm 1 cover plate with 15 push-in compartments 1 keep-safe compartment, 400 mm 1 bottom tray with cover plate, height 88 mm, with variable subdivisions 1 document compartment in lid</p> |
|---|---|---|---|

| | | | |
|--|--|--|---|
|  | <p>489 . 000 - 171 470 x 210 x 360 mm ~ 5.400 g X-ABS-Plastic black</p>  |       | <p>Classic moulded tool case the King-Size case 1 tool board with 25 push-in compartments 1 keep-safe compartment, 400 mm 1 tool board with 10 push-in compartments 1 cover plate with 15 push-in compartments 1 keep-safe compartment, 400 mm 1 bottom tray with cover plate, height 88 mm, with variable subdivisions 1 document compartment in lid</p> |
|--|--|--|---|

| | | | |
|---|---|---|--|
|  | <p>475 . 000 - 171 460 x 165 x 310 mm ~ 3.600 g X-ABS-Plastic black</p>  |       | <p>Classic moulded tool case designed for opening to 180° 4 tool boards with 68 push-in compartments 3 keep-safe compartments, 400 mm Metal hinges</p> |
|---|---|---|--|

PARAT, Made in Germany!



Locations and standards

"Made in Germany" - this statement is worldwide known as a synonym for highest quality of processing. Due to the high production volume in Germany most of our products are labelled with "Made in Germany". However in all our production plants the high quality of processing is applied.

Remscheid

The head office and foundation place of PARAT is located in Remscheid, the centre of the German tool industry. It is the heart of the whole PARAT group and the production of our subsidiary company BAMURE.

Neureichenau

In 1961 the production of sewn goods for the army started in Neureichenau in Bavaria. Two years later, the company got in the plastics technology business. Today 450 employees work at PARAT in Neureichenau in an area of 35,000 square metres. Besides the manufacturing of cases for tools and notebooks, the packing of the torches as well as the production of PARAT Automotive parts (such as folding roof tops for convertibles, tractor hoods and plastic parts for caravans and mobile homes) are made there.

Locations in other countries

In addition to the two traditional locations in Germany, production plants in Neuzeug/Austria, Szügy/Hungary and Sighisoara/Romania are also part of the PARAT group. There is also a production facility for folding roof tops of convertibles in Spartanburg in South Carolina/USA.





Silver

Simply, practical and good!

Silver tool cases are ideal for loads up to 20 kg. An all-round aluminium frame, integrated locks and a sturdy

handle make these cases highly functional and very easy to use.



Silver features at a glance:

- sturdy ABS shells
- 20 kg maximum load; aluminium frame
- sturdy handles
- integrated locks
- metal hinges
- lid holders
- sturdy Con-Pearl® tool boards



= Made in Germany

PARAT 

SILVER

Silver moulded tool case

empty - without interior fittings (look at accessories)

You can fit the case out in accordance with your requirements. PARAT sales staff will be pleased to provide advice.

Art. No



430 . 000 - 171

465 x 170 x 310 mm

~ 2.200 g

Plastic (ABS)

black



Silver moulded tool case

the slim case

1 tool board with 13 push-in compartments

1 cover plate with 15 push-in compartments

1 keep-safe compartment, 400 mm

1 bottom tray with cover plate, height 58 mm, with variable subdivisions

1 document compartment in lid

Art. No



431 . 000 - 171

465 x 120 x 310 mm

~ 3.800 g

Plastic (ABS)

black



Silver moulded tool case

comprehensively equipped

1 tool board with 25 push-in compartments

1 keep-safe compartment, 400 mm

1 tool board with 10 push-in compartments

1 cover plate with 15 push-in compartments

1 keep-safe compartment, 400 mm

1 bottom tray with cover plate, height 58 mm, with variable subdivisions

1 document compartment in lid

Art. No



432 . 000 - 171

465 x 170 x 310 mm

~ 4.200 g

Plastic (ABS)

black



Silver moulded tool case

the standard case

1 tool board with 25 push-in compartments

1 keep-safe compartment, 400 mm

1 cover plate with 15 push-in compartments

1 keep-safe compartment, 400 mm

1 bottom tray with cover plate, height 58 mm, with variable subdivisions

Art. No



433 . 000 - 171

465 x 170 x 310 mm

~ 3.700 g

Plastic (ABS)

black



ACCESSORIES

| | | | |
|---|---|--|--|
|  | <p>591 . 000 - 161 430 x 240 mm ~ 440 g Artificial leather/Con-Pearl® black</p> |      | <p>Tool board 2-sided Tool board with a total of 25 push-in compartments on front and back 1 keep-safe compartment, 400 mm</p> |
|  | <p>592 . 000 - 161 430 x 240 mm ~ 240 g Artificial leather/Con-Pearl® black</p> |      | <p>Tool board 1-sided Tool board with a total of 13 push-in compartments on front</p> |
|  | <p>594 . 000 - 161 430 x 240 mm ~ 240 g Artificial leather/Con-Pearl® black</p> |      | <p>Tool board 1-sided Tool board with a total of 10 push-in compartments</p> |
|  | <p>594 . 011 - 161 430 x 240 mm ~ 220 g Artificial leather/Con-Pearl® black</p> |      | <p>Tool board 2-sided 15 push-in compartments 1 keep-safe compartment, 400 mm</p> |

ACCESSORIES

Document compartment

for classic moulded tool case

1 compartment for A₄ documents
2 compartments for business cards, etc.

2 loops for writing utensils
document compartment
for silver moulded tool case
496.000.311

Art. No



596 . 000 - 311

460 x 310 mm

~ 300 g

Artificial leather/Con-Pearl®

black



Bottom tray

58 mm high, with variable subdivisions

1 long divider

3 short dividers

1 flush cover plate with 15 push-in compartments

1 keep-safe compartment, 400 mm (for cases with heights up to 310 mm) (except 431.000-171 and 484.000-171)

Art. No



598 . 000 - 161

420 x 275 x 58 mm

~ 1.140 g

Plastic (ABS)

black



Long divider for bottom tray

for 58 mm high bottom trays, with 7 guides on each side for variable division of bottom tray

Art. No



900 . 011 - 161

425 x 58 mm

~ 130 g

Polystyrene

black



Short divider for bottom tray

for 58 mm high bottom trays divisible for variable division of bottom tray

Art. No



900 . 013 - 161

278 x 58 mm





~ 50 g

Polystyrene

black



ACCESSORIES

| | | | |
|---|---|---------------------------------------|---|
|  | <p>497 . 000 - 171 400 x 280 mm ~ 280 g Plastic (ABS) black</p> | <p>Art. No. + Q COLOR</p> | <p>Perforated Board strong, removable perforated board Empty Padded back</p> |
|  | <p>900 . 007 - 988</p> | <p>Art. No. + Q COLOR</p> | <p>Accessories for perforated board 20 tool clamps 1 m rubber tape Fitting aid</p> |
|  | <p>900 . 008 - 988 Polyethylene red</p> | <p>Art. No. + Q COLOR</p> | <p>Accessories for perforated board 20 tool clamps, small</p> |
|  | <p>900 . 021 - 166 110 x 90 x 36 mm ~ 100 g Polystyrene red</p> | <p>Art. No. + Q COLOR</p> | <p>Tray insert with lid box for small parts 1 central divider 6 short dividers Transparent lid</p> |

Computers On Wheels

One-to-one computing
made easy!



PARADIDACT® is an innovative transport and storage solution for the IT-equipment of schools, seminars and training establishments. This system is available for up to 24 notebooks.

PARADIDACT® consists of an easy to move transport cart for 12, 18 or 24 notebooks and additional compartments for printer, projector and various accessories. By inserting the notebooks into the patented docking units they will be automatically charged and connected to the network. These docks can be customized to nearly any notebook. Via Wake-On-LAN the notebooks can be administrated by remote and via the internal access point the user have wireless access to the local network or the internet. The optional sound system enables multimedia applications in any room.

Benefits of the PARADIDACT® system are an easy handling, more flexibility and a cost reduction up to 40% compared with traditional computer rooms.





Top-Line

Everything under control!

Top-Line tool cases were developed in cooperation with professional users. They are very sturdy, extremely strong, and combine practicality with elegance. The handle, specially developed by PARAT, has ergo-

nomically designed recesses. The interior can easily be adapted to individual requirements using the versatile CP-7 tool holder system.



Top-Line features at a glance:





- sturdy embossed leather
- aluminium edge reinforcement or ABS sides for high strength
- ergonomic handles for easy carrying on some models, with grip recesses and sturdy metal handle rails
- variable locks or quick-action locks
- integrated bottom studs to protect case
- sturdy Con-Pearl®, interior fittings
- CP-7 tool holder system individually adaptable





 = double-walled





 = Made in EU



PARAT 

TOP-LINE

| | | | |
|---|---|--|---|
| <p>Top-Line tool case</p> | <p>Art.No</p>     | <p>14 . 000 - 581 415 x 165 x 275 mm ~ 3.500 g Genuine leather, Con-Pearl® black</p> |  |
| <p>with middle wall Fold-out front wall with 4 push-in compartments 1 pouch for small parts 1 keep-safe compartment Middle wall with 1 CP-7 tool holder, ø 11 mm 1 CP-7 tool holder, ø 15 mm Rear wall with 1 CP-7 tool holder, ø 26 mm Steel sheet bottom tray, galvanized Variable locks Ring caps</p> | | | |







| | | | |
|--|---|---|--|
| <p>Top-Line tool case</p> | <p>Art.No</p>     | <p>15 . 000 - 571 420 x 185 x 315 mm ~ 2.900 g Plastic (ABS), genuine leather, Con-Pearl® black</p> |  |
| <p>with middle wall Semi-fold-out front wall with 8 push-in compartments Middle wall with 1 CP-7 tool holder, ø 11 mm 1 CP-7 tool holder, ø 26 mm Handle hole Variable locks</p> | | | |





| | | | |
|--|---|---|---|
| <p>Top-Line tool case</p> | <p>Art.No</p>     | <p>16 . 000 - 571 420 x 185 x 315 mm ~ 3.100 g Plastic (ABS), genuine leather, Con-Pearl® black</p> |  |
| <p>with middle wall Semi-fold-out front and rear wall each with 8 push-in compartments Middle wall with 1 CP-7 tool holder, ø 11 mm 1 CP-7 tool holder, ø 26 mm Handle hole Variable locks</p> | | | |





| | | | |
|---|---|--|---|
| <p>Top-Line tool case</p> | <p>Art.No</p>     | <p>16 . 100 - 571 440 x 185 x 300 mm ~ 3.950 g HDPE plastic, genuine leather, Con-Pearl® black</p> |  |
| <p>with middle wall Semi-fold-out front wall with 10 push-in compartments Middle wall with 1 CP-7 tool holder, ø 11 mm 1 CP-7 tool holder, ø 26 mm Semi-fold-out rear wall with 13 push-in compartments handle hole, variable locks ring caps</p> | | | |
| <p>SPECIALS </p> | | | |

TOP-LINE

| | | | |
|---|--|---|--|
|  | <p>17 . 000 - 581</p> <p>460 x 210 x 340 mm</p> <p>~ 4.500 g</p> <p>HDPE plastic, genuine leather, Con-Pearl®</p> <p>black</p>  | <p>Art. No</p>    <p>COLOR</p>  <p>SPECIALS</p> | <p>Top-Line tool case</p> <p>with middle wall</p> <p>Semi-fold-out front wall with 1 CP-7 tool holder, ø 26 mm</p> <p>Middle wall with 1 CP-7 tool holder, ø 11 mm 1 CP-7 tool holder, ø 15 mm</p> <p>Semi-fold-out rear wall with 1 CP-7 tool holder, ø 15 mm</p> <p>handle hole, variable locks, ring caps</p> |
|---|--|---|--|

| | | | |
|--|---|--|--|
|  | <p>18 . 000 - 581</p> <p>460 x 210 x 340 mm</p> <p>~ 5.400 g</p> <p>HDPE plastic, genuine leather, Con-Pearl®</p> <p>black</p>  | <p>Art. No</p>    <p>COLOR</p>  <p>SPECIALS</p> | <p>Top-Line tool case</p> <p>with middle wall</p> <p>Semi-fold-out front wall with 1 CP-7 tool holder, ø 15 mm</p> <p>Middle wall with 1 CP-7 tool holder, ø 11 mm 1 CP-7 tool holder, ø 15 mm</p> <p>Semi-fold-out rear wall with 1 CP-7 tool holder, ø 26 mm</p> <p>Front pouch</p> <p>Plastic compartment with lid in bottom</p> <p>Variable locks, ring caps</p> |
|--|---|--|--|

| | | | |
|---|--|--|--|
|  | <p>18 . 000 - 586</p> <p>450 x 190 x 340 mm</p> <p>~ 4.700 g</p> <p>Genuine leather, Con-Pearl®</p> <p>red</p> | <p>Art. No</p>    <p>COLOR</p> | <p>Top-Line tool case</p> <p>with middle wall</p> <p>Semi-fold-out front wall with 1 CP-7 tool holder, ø 15 mm</p> <p>Middle wall with 1 CP-7 tool holder, ø 11 mm 1 CP-7 tool holder, ø 15 mm</p> <p>Semi-fold-out rear wall with 1 CP-7 tool holder, ø 26 mm</p> <p>Front pouch, all-round strap</p> <p>Plastic compartment with lid in bottom</p> <p>Variable locks</p> |
|---|--|--|--|

| | | | |
|---|--|--|---|
|  | <p>30 . 000 - 581</p> <p>220 x 140 x 250 mm</p> <p>~ 1.300 g</p> <p>Genuine leather, Con-Pearl®</p> <p>black</p> | <p>Art. No</p>    <p>COLOR</p> | <p>Top-Line tool case</p> <p>with middle wall</p> <p>Front, rear and middle wall with 17 push-in compartments</p> <p>Transparent compartment in top</p> <p>Adjustable carrying strap</p> <p>Quick-action lock</p> |
|---|--|--|---|

TOP-LINE

















| | | | |
|--|--|--|--|
| <p>Top-Line tool case</p> | | <p>31 . 000 - 581</p> | |
| <p>without middle wall Semi-fold-out front wall with 1 CP-7 tool holder, ø 26 mm Rear wall with 1 CP-7 tool holder, ø 15 mm Front pouch Variable locks Ring caps</p> | | <p>440 x 185 x 300 mm</p> | |
| | | <p>~ 2.900 g</p> | |
| | | <p>HDPE plastic, genuine leather, Con-Pearl®</p> | |
| | | <p>black</p> | |
| | | | |

| | | | |
|--|--|--|--|
| <p>Top-Line tool case</p> | | <p>33 . 000 - 581</p> | |
| <p>without middle wall Semi-fold-out front wall with 1 CP-7 tool holder, ø 15 mm Rear wall with 9 loops Front pouch Variable locks Ring caps</p> | | <p>420 x 160 x 250 mm</p> | |
| | | <p>~ 2.700 g</p> | |
| | | <p>HDPE plastic, genuine leather, Con-Pearl®</p> | |
| | | <p>black</p> | |
| | | | |

| | | | |
|---|--|------------------------------------|--|
| <p>Top-Line tool case</p> | | <p>36 . 000 - 581</p> | |
| <p>without middle wall Front wall with 1 keep-safe compartment Loops for spirit level All-round strap Steel sheet bottom tray, galvanized Variable locks</p> | | <p>600 x 160 x 215 mm</p> | |
| | | <p>~ 3.500 g</p> | |
| | | <p>Genuine leather, Con-Pearl®</p> | |
| | | <p>black</p> | |
| | | | |

| | | | |
|--|--|---|--|
| <p>Top-Line case with drawers</p> | | <p>42 . 000 - 571</p> | |
| <p>5 drawers Fold-out front wall 50 mm stowage space behind drawers Portable carrying insert Compartment for small parts Handle hole, variable locks</p> | | <p>410 x 180 x 310 mm</p> | |
| | | <p>~ 4.100 g</p> | |
| | | <p>Plastic (ABS), genuine leather, Con-Pearl®</p> | |
| | | <p>black</p> | |
| | | | |

TOP-LINE

| | | | |
|---|---|--|--|
|  | <p>43 . 000 - 561 410 x 190 x 280 mm ~ 4.000 g OPOMAT, Con-Pearl® black</p> | <p>Art. No.    COLOR</p> | <p>Top-Line case with drawers</p> <p>4 drawers Fold-out front wall Middle wall with 1 CP-7 tool holder, ø 15 mm Semi-fold-out rear wall with 1 CP-7 tool holder, ø 26 mm Portable carrying insert Compartment for small parts Quick-action locks</p> |
|  | <p>43 . 000 - 581 410 x 190 x 280 mm ~ 4.600 g Genuine leather, Con-Pearl® black</p> | <p>Art. No.    COLOR</p> | <p>Top-Line case with drawers</p> <p>4 drawers Fold-out front wall Middle wall with 1 CP-7 tool holder, ø 15 mm Semi-fold-out rear wall with 1 CP-7 tool holder, ø 26 mm Portable carrying insert Compartment for small parts Quick-action locks</p> |
|  | <p>44 . 000 - 581 410 x 220 x 310 mm ~ 4.900 g Genuine leather, Con-Pearl® black</p> | <p>Art. No.    COLOR</p> | <p>Top-Line case with drawers</p> <p>5 drawers Fold-out front wall Rear wall with 1 CP-7 tool holder, ø 15 mm 90 mm stowage space behind drawers Portable carrying insert Compartment for small parts Variable locks</p> |
|  | <p>51 . 000 - 571 360 x 110 x 170 mm ~ 700 g Plastic (ABS), genuine leather, Con-Pearl® black</p> | <p>Art. No.    COLOR</p> | <p>Top-Line universal case</p> <p>without interior fittings Quick-action locks</p> |

TOP-LINE

Top-Line universal case

Rear wall with
1 keep-safe compartment
Handle hole
Variable locks



57 . 000 - 571
465 x 180 x 310 mm
~ 2.200 g
Genuine leather, Plastic (ABS)
black



Top-Line flap-lock case

with
17 push-in compartments
4 loops
Quick-action lock



60 . 000 - 061
320 x 50 x 250 mm
~ 800 g
Artificial leather
black



ACCESSORIES

Tray insert, empty



900 . 002 - 166
110 x 90 x 36 mm
~ 45 g
Polystyrene
red







Central divider



900 . 003 - 166
110 x 36 mm
~ 8 g
Polystyrene
red



ACCESSORIES

| | | | |
|---|--|---------------------------------------|--|
|  | <p>900 . 004 - 166 43 x 36 mm ~ 3 g Polystyrene red</p> | <p>Art. No. + g COLOR</p> | <p>Short divider</p> |
|  | <p>900 . 021 - 166 110 x 90 x 36 mm ~ 100 g Polystyrene red</p> | <p>Art. No. + g COLOR</p> | <p>Tray insert with lid box for small parts 1 central divider 6 short dividers Transparent lid</p> |
|  | <p>900 . 005 - 251 1120 x 20 mm ~ 145 g Polyester belt black</p> | <p>Art. No. + g COLOR</p> | <p>Carrying strap adjustable, with 2 carabines Shoulder pad</p> |
|  | <p>900 . 017 - 081 50 x 40 mm ~ 50 g Genuine leather black</p> | <p>Art. No. + g COLOR</p> | <p>Set of ring caps</p> |

The perfect protection for tools and more



As part of a visual tool safeguarding system, precisely-fitting foam inlays serve to protect valuable tools and measuring equipment. These inlays can be used in our range of cases, but also in other receptacles, workshop trolleys or production facilities. As each tool has its own particular place in a location that is made of coloured foam, it is easy to see when a tool is missing.

PARAT has acquired its own new foam mill for the production of inlays adapted to fit individual customer requirements. The CNC controlled machine works simultaneously with four tool heads – and is thus able to quickly fulfil even the larger orders. Before the foam inlays can be milled, the tools to be kept are scanned three-dimensionally. The computer then uses this data to calculate the best possible dimensions for the inlays. These foam inlays are suitable not only for high value tools and tools with a safety requirement; they are also ideal for the secure and prestigious presentation and accommodation of other goods.

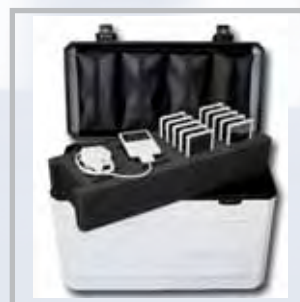



New Classic

In a class of their own!

Form follows function! This is the PARAT philosophy for the design of moulded tool cases and leather tool cases with very specific features precisely adapted to customers' needs.



New Classic features at a glance:

- embossed leather
- some of the cases are reinforced by aluminium brackets or ABS sides
- sturdy handles, some with metal grip rails
- ratchet or barrel locks
- integrated bottom studs to protect case
- extremely sturdy
- good value for money
- proven interior fittings
- enhanced standing security
- higher moisture resistance

 = double-walled

 = Made in EU

PARAT 

NEW CLASSIC

New Classic case with drawers

- 5 drawers
- Fold-out front wall
- Compartment for small parts
- Quick-action locks



100 . 000 - 041
 410 x 130 x 310 mm
 ~ 3.400 g
 OPOMAT
 black



New Classic case with drawers

- 5 drawers
- Fold-out front wall
- Compartment for small parts
- 40 mm stowage space behind drawers
- Quick-action locks



110 . 000 - 041
 410 x 170 x 310 mm
 ~ 3.700 g
 OPOMAT
 black



New Classic case with drawers

- 4 drawers
- Fold-out front wall
- Middle wall with 9 loops
- Semi-fold-out rear wall, with 11 adjustable loops
- Portable carrying insert
- Compartment for small parts
- PARAT quick-action locks
- Case with aluminium edge reinforcement



130 . 000 - 031
 410 x 190 x 280 mm
 ~ 4.700 g
 Genuine leather
 black



New Classic tool case































- with middle wall
- Fold-out front wall with 8 push-in compartments
- Removable middle wall with 10 adjustable loops on front
- Rear wall with keep-safe compartment
- Steel sheet bottom tray, galvanized
- Quick-action locks



370 . 000 - 041
 400 x 130 x 280 mm
 ~ 2.700 g
 OPOMAT
 black



NEW CLASSIC

| | | | |
|---|---|---|---|
|  | <p>5460 . 000 - 031 440 x 185 x 300 mm ~ 3.800 g Genuine leather/HDPE black</p>  |       | <p>New Classic tool case with middle wall Semi-fold-out front wall with 11 loops Fixed middle wall with 8 sewn push-in compartments and 9 loops Semi-fold-out rear wall with 11 loops PARAT quick-action locks bottom tray Case with aluminium edge reinforcement ring caps</p> |
|  | <p>5470 . 000 - 031 460 x 210 x 340 mm ~ 4.400 g Genuine leather/HDPE black</p>  |       | <p>New Classic tool case with middle wall Fold-out front wall with 9 loops Fixed middle wall with 11 adjustable and 8 adjustable loops Semi-fold-out rear wall with 11 loops bottom tray, PARAT quick-action locks 2 closing straps, ring caps case with aluminium edge reinforcement</p> |
|  | <p>5471 . 000 - 031 460 x 210 x 340 mm ~ 4.700 g Genuine leather/HDPE black</p>  |       | <p>New Classic tool case with middle wall Semi-fold-out front wall with 9 loops Fixed middle wall with 19 loops Semi-fold-out rear wall with 11 loops Side walls with 4 loops Loops for spirit level, front pouch bottom tray, PARAT quick-action locks 2 closing straps, ring caps, case with aluminium edge reinforcement</p> |
|  | <p>2460 . 000 - 401 390 x 185 x 310 mm ~ 2.800 g Genuine leather, Plastic (ABS) black</p> |      | <p>New Classic tool case with middle wall Semi-fold-out front and rear walls each with 8 push-in compartments Removable middle wall with each 10 adjustable loops on front and back Variable locks Handle hole</p> |

NEW CLASSIC

New Classic tool case

with middle wall

Fold-out front wall with
8 adjustable loops, 1 compartment for
small parts, 1 push-in compartment
Removable middle wall, with
11 loops, 1 keep-safe compartment
Rear wall with 9 loops
galvanized steel bottom tray
Quick-action locks



5380 . 000 - 031
400 x 140 x 280 mm
~ 3.000 g
Genuine leather
black



New Classic universal case

with middle wall

Front, middle and rear wall with
17 push-in compartments
Transparent compartment in lid
Adjustable, removable carrying strap
Quick-action locks



5304 . 000 - 031
220 x 140 x 250 mm
~ 1.200 g
Genuine leather
black



New Classic universal case

Fold-out front wall with
11 adjustable loops
Rear wall with
8 sewn push-in compartments
Bottom tray
Quick action locks
ring caps



5360 . 000 - 031
440 x 185 x 300 mm
~ 2.900 g
Genuine leather/HDPE
black



New Classic universal case

















without interior fittings
Quick-action locks



2220 . 000 - 401
360 x 110 x 170 mm
~ 600 g
Plastic (ABS), genuine
leather, Con-Pearl®
black



NEW CLASSIC

| | | | |
|---|---|--|--|
|  | <p>2228 . 000 - 401 390 x 170 x 230 mm ~ 1.400 g Genuine leather, Plastic (ABS) black</p> | <p>Art. No.    COLOR</p> | <p>New Classic universal case without interior fittings Quick-action locks</p> |
|  | <p>5200 . 000 - 031 340 x 110 x 170 mm ~ 800 g Genuine leather black</p> | <p>Art. No.    COLOR</p> | <p>New Classic universal case without interior fittings Quick-action locks</p> |
|  | <p>5203 . 000 - 031 370 x 110 x 250 mm ~ 1.400 g Genuine leather black</p> | <p>Art. No.    COLOR</p> | <p>New Classic universal case Rear wall with 10 adjustable loops Quick-action locks Ring caps</p> |
|  | <p>5207 . 000 - 031 410 x 160 x 300 mm ~ 2.100 g Genuine leather black</p> | <p>Art. No.    COLOR</p> | <p>New Classic universal case Rear wall with 8 adjustable loops Quick-action locks Ring caps</p> |

NEW CLASSIC

New Classic universal tool case

Semi-fold-out front wall, with
11 adjustable loops
Rear wall with
9 loops
Front pouch, ring caps
PARAT quick-action locks
Side walls and bottom tray
made of HDPE
Case with aluminium edge
reinforcement

Art. No



5363 . 000 - 031

420 x 160 x 250 mm

~ 2.600 g

Genuine leather/HDPE

black



New Classic presentation case

with all round zip
fastener and
2 perforated boards
20 band clips
1 m of rubber band
Insertion tool
1 transparent pocket for business cards
outside the document folio

Art. No



5650 . 020 - 061

310 x 250 x 30 mm

~ 1.100 g

Artificial leather

black



ACCESSORIES

Carrying strap

adjustable, with
2 carabines
Shoulder pad

Art. No



900 . 005 - 251

1120 x 20 mm

~ 145 g

Polyester belt

black



Tray insert, empty

Art. No



900 . 002 - 169

110 x 90 x 36 mm

~ 45 g

Polystyrene

white





Basic

Typical tidiness, homestyle!

PARAT has the right case for all do-it-yourself work. These cases are ideal for less severe professional service and for the home handyman.

The outstanding tool holder sets and tool strips feature professional quality and keep the wall of your workshop tidy.

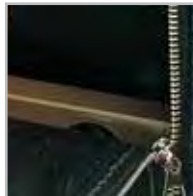

Features of Basic tool cases at a glance:





- Opomat
- carrying handles
- variable or quick-action locks
- integrated bottom studs to protect case













= Made in EU





PARAT 

BASIC

| | | | |
|----------------------------------|---|--|---|
| <p>Double-walled case</p> | <p>Art. No.    </p> | <p>5084 . 000 - 151 435 x 145 x 320 mm ~ 4.700 g Polypropylene black</p> |  |
|----------------------------------|---|--|---|

| | | | |
|--------------------------|---|--|--|
| <p>Basic case</p> | <p>Art. No.    </p> | <p>380 . 000 - 051 400 x 135 x 280 mm ~ 2.400 g OPOMAT black</p> |  |
|--------------------------|---|--|--|

| | | | |
|--------------------------|---|--|--|
| <p>Basic case</p> | <p>Art. No.    </p> | <p>5310 . 000 - 061 425 x 155 x 225 mm ~ 1.600 g Compressed cardboard, PVC-film black</p> |  |
|--------------------------|---|--|--|

| | | | |
|--------------------------|---|--|---|
| <p>Basic case</p> | <p>Art. No.    </p> | <p>361 . 005 - 051 420 x 155 x 255 mm ~ 2.200 g OPOMAT black</p> |  |
|--------------------------|---|--|---|

BASIC

| | | | |
|---|--|---------------------------------------|---|
|  | <p>5990 . 504 - 991 320 x 170 x 425 mm ~ 1.850 g nylon grey, black</p> | <p>Art. No. + g COLOR</p> | <p>Tool backpack reinforced by inside plastic frames big storage compartment inside with 16 push-in compartments 5 rubber loops 2 keep-safe compartments for documents 1 voluminous storage compartment patch pocket with compartments for business cards, pens etc. 1 padded rear wall, 1 adjustable chest strap, 1 intensified handle 2 adjustable, padded carrying straps</p> |
|---|--|---------------------------------------|---|

TOOL ROLLS

| | | | |
|--|---|---------------------------------------|--|
|  | <p>5535 . 000 - 060 750 x 330 mm ~ 340 g Artificial leather black</p> | <p>Art. No. + g COLOR</p> | <p>Tool roll with strap catch 5535.000-060 20 compartments 5530.000-060 5 comp's, 280x305 mm, 120g 5531.000-060 8 comp's, 380x320 mm, 160g 5532.000-060 10 comp's, 475x325 mm, 200g 5533.000-060 12 comp's, 550x315 mm, 260g 5534.000-060 15 comp's; 660x315 mm, 300g</p> |
|--|---|---------------------------------------|--|

| | | | |
|---|---|---------------------------------------|---|
|  | <p>5570 . 000 - 051 440 x 520 mm ~ 720 g Artificial leather black</p> | <p>Art. No. + g COLOR</p> | <p>Tool roll with 19 push-in compartments Quick-action locks</p> |
|---|---|---------------------------------------|---|

TOOL HOLDER

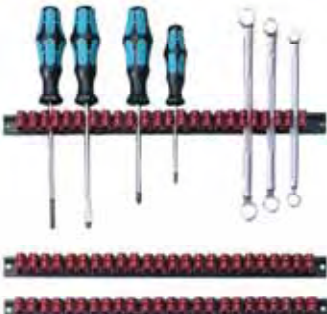
| | | | |
|---|--|---------------------------------------|--|
|  | <p>802 . 000 - 981 330 x 20 mm ~ 300 g PVC</p> | <p>Art. No. + g COLOR</p> | <p>Clipstrip set 3 strips, each with 12 flexible double clips</p> |
|---|--|---------------------------------------|--|

PARATRON®

Gun travelling bag

The best place for your gun!



The voluminous travelling bags of the PARATRON® system have sufficient space not only for the gun case but also for your complete hunting equipment.

All the bags feature outstanding workmanship and a variety of design details: All corners and edge protectors have brown leather reinforcement. The all-round polyester carrying straps are 40 mm wide and feature two adjustable tightening straps and quick action fasteners. The pull-handle and carrying handle also have a leather covering and a leather address label compartment concealed under the zip cover. Continuous plastic bottom slides support the 6 mm Con-Pearl® bottom plate and house two rollers with ball bearings.

The push-in compartment for the gun case, which is invisible from the outside, is reinforced by a removable all-round Con-Pearl® shell.

External dimensions (all models): 100 x 38 x 42 cm

Weight: 4.1 to 4.5 kg.

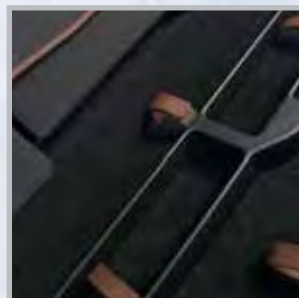
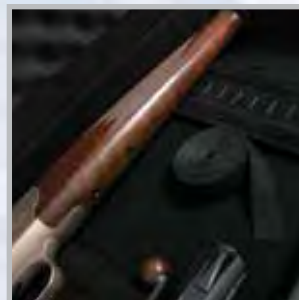
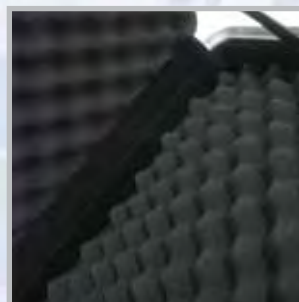



Belt pouches

Everything under control

The belt pouches simplify the mobile working. With this belt pouch the craftsman has his tools, screws or nails always ready to hand but anyhow one or even two hands free.

These pouches are ideal while working on the ladder or scaffold. The new programme includes common products and therefore completes the PARAT's assortment.

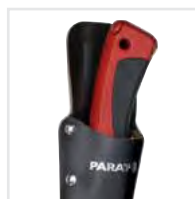
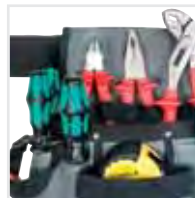

Belt pouches features at a glance:





















- loop for fixing the belt pouch
- made of high-quality nylon 600 D or genuine leather
- tools are ready to hand
- various possibilities to equip tools
- overview at first sight











= Made in EU

PARAT 

BELT POUCHES

| | | |
|--|---|---|
| <p>Belt pouch</p> <p>big 5 push-in compartments 1 hammer holder 1 holder for insulating tape with a snap hook 1 big main compartment with 4 rubber loops 1 nylon belt 1.250 x 48 mm, adjustable and removable</p> | <p>Art.No 5990 . 814 - 999</p> <p> 200 x 100 x 300 mm</p> <p> ~ 380 g</p> <p> nylon</p> <p> grey, black</p> |  |
| <p>Double belt pouch</p> <p>big both belt pouches, each with: 5 push-in compartments 1 hammer holder 1 big front bag 2 big main compartments with 3 push-in compartments 1 separate holder for measuringtape 1 nylon belt 1.250 x 48 mm, adjustable and removable</p> | <p>Art.No 5990 . 815 - 999</p> <p> 200 x 100 x 300 mm</p> <p> ~ 674 g</p> <p> nylon</p> <p> grey, black</p> |  |
| <p>Belt pouch</p> <p>small 5 push-in compartments 1 big main compartment 1 holder for insulating tape with a snap hook 1 hammer holder 1 button clip for fixation on the belt</p> | <p>Art.No 5990 . 816 - 999</p> <p> 150 x 30 x 260 mm</p> <p> ~ 108 g</p> <p> nylon</p> <p> grey, black</p> |  |
| <p>Mobile phone bag</p> <p>1 big mobile phone compartment 110 x 55 x 25 mm 1 hook-and-loop fastener 1 belt-loop 1 metal clip</p> | <p>Art.No 5990 . 817 - 999</p> <p> 155 x 90 x 25 mm</p> <p> ~ 68 g</p> <p> nylon</p> <p> grey, black</p> |  |

BELT POUCHES

| | | | |
|---|---|--|---|
|  | <p>5990 . 818 - 999 266 x 131 mm ~ 69 g nylon grey, black</p> |  | <p>Wallet</p> <ul style="list-style-type: none"> 1 big compartment, for bank notes / passes 2 compartments with zipper 5 compartments for cards 1 big hook-and-loop fastener |
|  | <p>5990 . 819 - 081 160 x 55 x 35 mm 30 g Genuine leather black</p> |  | <p>Hammer holder</p> <ul style="list-style-type: none"> 1 loop for fixation on the belt 1 hammer loop with button clip to fix the hammer |
|  | <p>5990 . 820 - 081 220 x 80 x 25 mm 59 g Genuine leather black</p> |  | <p>Knife bag for the belt suitable for various types of knives</p> |
|  | <p>5990 . 821 - 031 120 x 150 x 75 mm 121 g Genuine leather black</p> |  | <p>Nail bag duplex 2 main compartments for nails/screws 2 loops to affix it on the belt</p> |

SIMPLY PRACTICAL!



Belt pouches are ideal for working on a ladder or scaffolds. With the belt pouch the craftsman has his tools, screws or nails always ready to hand but anyhow one or even two hands free. This range consists of eight items. Five products are made of high-quality nylon 600 in grey/black colour. Three articles are made of black genuine leather.

The new programme includes common products such as the single and double belt pouches, the classical nail and knife bag as well as a hammer holder. A wallet and a mobile phone bag complete the range. With these new belt pouches from PARAT – the craftsman while standing on the ladder or scaffold has his tools always within reach.





PROFI-LINE

Tool boxes with system!

PARAT plastic boxes are strong, spacious and versatile, offering professional users the features they need for a variety of applications. All tool boxes are equipped with an integrated compartment for small parts and a removable tray. The container and the boxes

made of high-grade plastic resist attack by oils and chemicals and are surprisingly light. The high voluminous container is optionally available with or without wheels. The model with wheels guarantees an easy transport which helps preventing back problems.



The features of the Profi-Line series at a glance:





- resistant to attack by oils and chemicals
- high-grade plastic polypropene
- high voluminous container optionally available with or without wheels
- available in different sizes
- integrated compartment for small parts and removable trays inside the boxes
- locking by padlock possible
- integrated handle with interlock operation





 = with wheels





 = Made in EU





PARAT 

PROFI-LINE







| | | |
|--|--|---|
| <p>Profi-Line tool box</p> <ul style="list-style-type: none"> with removable tray 2 latches 1 integrated handle with interlock operation 1 removable compartment for small parts 1 removable tray Locking by padlock possible | <p>Art. No. 5811 . 000 - 391</p> <p> 440 x 230 x 235 mm</p> <p> ~ 1.820 g</p> <p> Polypropylene</p> <p> black</p> |  |
|--|--|---|





| | | |
|--|--|--|
| <p>Profi-Line tool box</p> <ul style="list-style-type: none"> with removable tray 2 latches 1 integrated handle with interlock operation 1 removable compartment for small parts 1 removable tray Locking by padlock possible | <p>Art. No. 5812 . 000 - 391</p> <p> 475 x 257 x 255 mm</p> <p> ~ 2.235 g</p> <p> Polypropylene</p> <p> black</p> |  |
|--|--|--|





| | | |
|--|--|---|
| <p>Profi-Line tool box</p> <ul style="list-style-type: none"> with removable tray 2 latches integrated handle with interlock operation 1 removable compartment for small parts 1 removable tray Locking by padlock possible | <p>Art. No. 5813 . 000 - 391</p> <p> 585 x 290 x 280 mm</p> <p> ~ 3.060 g</p> <p> Polypropylene</p> <p> black</p> |  |
|--|--|---|

| | | |
|--|--|---|
| <p>Profi-Line tool container</p> <ul style="list-style-type: none"> large, with removable tray 2 latches 2 removable trays 2 removable compartments for small parts 2 collateral recessed grips locking by padlock possible | <p>Art. No. 5814 . 100 - 391</p> <p> 635 x 450 x 420 mm</p> <p> ~ 4.200 g</p> <p> Polypropylene</p> <p> black</p> |  |
|--|--|---|

PROFI-LINE

| | | | |
|---|---|--|---|
|  | <p>5814 . 500 - 391 635 x 450 x 420 mm ~7,550 g Polypropylene black</p>  | <p>Art. No.</p>    <p>COLOR</p>  | <p>Profi-Line tool container</p> <p>with wheels 2 latches 2 removable trays 2 removable compartments for small parts 2 collateral recessed grips 2 wheels 1 telescopic handle locking by padlock possible</p> |
|---|---|--|---|

| | | | |
|--|---|---|--|
|  | <p>5853 . 000 - 391 460 x 330 x 80 mm ~ 1.110 g Polypropylene black</p> | <p>Art. No.</p>    <p>COLOR</p> | <p>Profi-Line assortment box</p> <p>for small parts 1 large handle, integrated into the design 5 to max. 26 compartments, individual adjustable 2 latches, clear cover stackable</p> |
|--|---|---|--|

| | | | |
|---|---|---|--|
|  | <p>5854 . 000 - 391 390 x 290 x 60 mm ~ 1.000 g Polypropylene black</p> | <p>Art. No.</p>    <p>COLOR</p> | <p>Profi-Line assortment box</p> <p>for small parts 1 large handle, integrated into the design 5 to max. 26 compartments, individual adjustable 2 latches, clear cover stackable</p> |
|---|---|---|--|

RATHER FIND THAN SEARCH

Elaborated storage makes
working easy



The new PARAT range of plastic boxes is especially suitable for professionals. The most prominent features of the new product range are the improvements in quality and the ambitious design.

The existing assortment has been improved to enhance the product range. The design meets higher expectations. Small details such as the integrated measuring scale on the lid complete the visual impression. The new boxes are better equipped and are less expensive than the former ones, due to a more modern manufacturing process. All plastic boxes have fixtures for attaching a padlock. Furthermore an integrated compartment for small parts as well as a removable tray are standard interior equipment. The integrated handle is not only for facilitating the transport but also a locking mechanism for the lid.

We offer plastic boxes in three different sizes. The product line has been expanded to include a large container measuring 635 x 450 x 420 mms, available with or without wheels/telescopic handle.

Two individual compartments for small parts complete the range.





PARAPRO

Tough on the outside but sensitive at heart

The cases are made of thick-walled polypropylene, are indestructible and therefore still sturdier than standard cases customarily used for air travel. Additionally all Parapro cases are 100% waterproof, dustproof and airtight, which protects the contents from outside influences. The design of these special cases is created to

allow cases of the same size to be stacked without slipping. Larger models have wheels that allow a comfortable transport and also protect your back from injuries.



Features of the PARAPRO cases at a glance:

- 100% waterproof, dustproof and airtight
- Stackable
- Indestructible
- Meets military standards
- Large sizes optional with wheels
- Pressure compensating valve
- Fixture for a padlock
- Address label
- Comes empty or with a styrofoam insert



= exceptionally sturdy



= with wheels





= waterproof





= Made in EU









PARAT









| | | |
|---|---|---|
| <p>PARAPRO CASE 6222</p> <p>Special Cases Pressure compensating valve Circumferential neoprene gasket 1 handle 2 latches, 4 bottom studs Integrated address/name badge Lid-/bottom dimension 20mm/125mm Locking by padlock possible</p> <p>Article no. 6.222.001.391 with pre-cutted foam inlays ~ 1.290 g</p> | <p>Art.No 6.222 . 000 - 391</p> <p>220 x 160 x 145 mm</p> <p>~1.160 g</p> <p>Polypropylene</p> <p>black</p> <p>SPECIALS</p> |  |
|---|---|---|









| | | |
|--|---|---|
| <p>PARAPRO CASE 6270</p> <p>Special Cases Pressure compensating valve Circumferential neoprene gasket 1 handle 2 latches, 4 bottom studs Integrated address/name badge Lid-/bottom dimension 35mm/85mm Locking by padlock possible</p> <p>Article no. 6.330.001.391 with pre-cutted foam inlays ~ 1.830 g</p> | <p>Art.No 6.270 . 000 - 391</p> <p>276 x 200 x 120 mm</p> <p>~1.620 g</p> <p>Polypropylene</p> <p>black</p> <p>SPECIALS</p> |  |
|--|---|---|









| | | |
|---|---|---|
| <p>PARAPRO CASE 6330</p> <p>Special Cases Pressure compensating valve Circumferential neoprene gasket 1 handle 2 latches, 4 bottom studs Integrated address/name badge Lid-/bottom dimension 68mm/102mm Locking by padlock possible</p> <p>Article no. 6.330.001.391 with pre-cutted foam inlays ~ 2.510 g</p> | <p>Art.No 6.330 . 000 - 391</p> <p>330 x 234 x 170 mm</p> <p>~2.290 g</p> <p>Polypropylene</p> <p>black</p> <p>SPECIALS</p> |  |
|---|---|---|

| | | |
|---|---|---|
| <p>PARAPRO CASE 6332</p> <p>Special Cases Pressure compensating valve Circumferential neoprene gasket 1 handle 2 latches, 4 bottom studs Integrated address/name badge Lid-/bottom dimension 45mm/135mm Locking by padlock possible</p> <p>Article no. 6.332.001.391 with pre-cutted foam inlays ~ 3.580 g</p> | <p>Art.No 6.332 . 000 - 391</p> <p>380 x 270 x 180 mm</p> <p>~3.140 g</p> <p>Polypropylene</p> <p>black</p> <p>SPECIALS</p> |  |
|---|---|---|

| | | | |
|---|---|--|---|
|  | <p>6.440 . 000 - 391 445 x 345 x 125 mm ~3.400 g Polypropylene black</p> <p> </p> | <p>     </p> | <p>PARAPRO CASE 6440</p> <p>Special Cases Pressure compensating valve Circumferential neoprene gasket 1 handle 2 latches, 4 bottom studs Integrated address/name badge Lid-/bottom dimension 47mm/78mm Locking by padlock possible</p> <p>Article no. 6.440.001.391 with pre-cutted foam inlays ~ 3.900 g</p> |
|---|---|--|---|

| | | | |
|---|---|---|--|
|  | <p>6.442 . 000 - 391 445 x 345 x 190 mm ~4.000 g Polypropylene black</p> <p> </p> | <p>     </p> | <p>PARAPRO CASE 6442</p> <p>Special Cases Pressure compensating valve Circumferential neoprene gasket 1 handle 2 latches, 4 bottom studs Integrated address/name badge Lid-/bottom dimension 47mm/143mm Locking by padlock possible</p> <p>Art.-Nr. 6.442.001.391 with precisely-fitting foam inlays ~ 4.700 g</p> |
|---|---|---|--|

| | | | |
|---|---|--|--|
|  | <p>6.480 . 000 - 391 480 x 370 x 205 mm ~4.640 g Polypropylene black</p> <p> </p> | <p>     </p> | <p>PARAPRO CASE 6480</p> <p>Special Cases Pressure compensating valve Circumferential neoprene gasket 1 handle 2 latches, 4 bottom studs Integrated address/name badge Lid-/bottom dimension 50mm/155mm Locking by padlock possible</p> <p>Art.-Nr. 6.480.001.391 with precisely-fitting foam inlays ~ 5.400 g</p> |
|---|---|--|--|

| | | | |
|---|---|--|--|
|  | <p>6.580 . 000 - 391 580 x 440 x 220 mm ~6.960 g Polypropylene black</p> <p> </p> | <p>     </p> | <p>PARAPRO CASE 6580</p> <p>Special Cases Pressure compensating valve Circumferential neoprene gasket 1 handle, 2 collateral carry handles 4 latches, 4 bottom studs Integrated address/name badge Lid-/bottom dimension 60mm/160mm Locking by padlock possible</p> <p>Art.-Nr. 6.580.001.391 with precisely-fitting foam inlays ~ 8.190 g</p> |
|---|---|--|--|

PARAPRO Case 6582

with wheels

Pressure compensating valve
Circumferential neoprene gasket
3 carry handles, 2 wheels
1 adjustable telescopic handle
4 latches, 4 bottom studs
Integrated address/name badge
Lid-/bottom dimension 60mm/160mm
Locking by padlock possible

Article no. 6.582.010.391
with pre-cutted foam inlays
~ 11.660 g



6.582 . 009 - 391



580 x 440 x 230 mm



~9.550 g



Polypropylene



black



The PARAPRO range

Case for the most extreme situations



Our most popular products are in our catalogue and are in stock.

Among the standard products in our catalogue, other colours and sizes can be supplied on request within six to eight weeks. Special colours according to RAL or Pantone specifications can also be supplied, based on a minimum quantity. The cases are either available empty or with pre-cut foam. A specially purchased milling machine allows us to match the customers' requirements individually and to customize the foam insert. Perfectly fitting foam inserts protect the valuable tools and measuring instruments.



The cases are made of thick-walled polypropylene, are indestructible and therefore still sturdier than the standard cases customarily used for air travel. In addition all special cases are 100 % waterproof, airtight and dustproof and protect the content against all physical impacts.



The cases are indestructible at temperatures between $-33\text{ }^{\circ}\text{C}$ und $+90\text{ }^{\circ}\text{C}$. Our special cases also meet the NATO military specifications. If stored for a long time under or overpressure may result due to temperature variation inside the cases. That can always be adjusted by using a valve.

Furthermore the design makes it possible for cases of the same size to be stacked without slipping. The larger models are equipped with wheels to ensure a comfortable transport which protects your back from injuries.



Sturdier to last longer

A model series of virtually indestructible waterproof cases - the solution for equipment of every description that requires maximum protection.

Our warranty for breakages

In the unlikely event that one of our PARAPRO cases should ever break, we will provide a replacement free of charge.

Applications

The sturdy water and airtight construction of the PARAPRO cases assures optimum protection, even in the harshest environments. A whole range of tests were made to verify the qualification of the PARAPRO cases under extreme conditions to ensure conformance to the following ambitious standards:

IP67 dust proof. Water resistant - Defence Standard 81 - 41 Level J STANAG 4280 (edition 2) - conform to EU-Directive 2002/95/EC.

With their excellent features the PARAPRO cases are the first choice when it comes to the protection of important and valuable objects during transport.

Areas of application include:

- Military
- Emergency Medical Services
- Industry
- Offshore
- Sea travel
- Photography
- Broadcasting
- Police

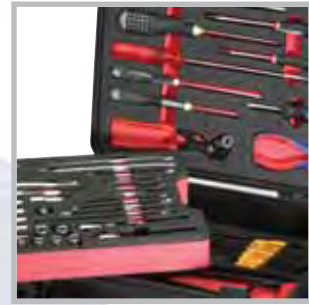

www.parat.de



Pilot

The first impression counts!

PARAT organisation cases are highly functional and convenient to use and feature a modern design. These are classic cases with materials and workmanship satisfying the most stringent quality requirements.



Features of the Pilot serie at a glance:

- genuine leather
- ergonomic handles with grip recesses for easy carrying
- PARAT combination locks on pilot cases
- integrated bottom studs to protect case
- fittings for files, documents, notebooks, etc.







= with wheels















= Made in EU

PARAT 





PILOT CASES

| | | |
|--|---|---|
| <p>Pilot case</p> <p>with front pouch front pouch for size A 4 Inside with</p> <ul style="list-style-type: none"> 3 push-in compartments each approx. 410 x 265 mm 1 padded notebook compartment approx. 425 x 50 x 285 mm 2 business card compartments, 2 loops for pens, files can be carried in a vertical position, Two-tone combination locks, Handle hole | <p>Art. No 5074 . 000 - 021</p> <p> 425 x 180 x 335 mm</p> <p> ~ 4.200 g</p> <p> Genuine leather</p> <p> black</p> |  |
|--|---|---|

| | | |
|---|--|--|
| <p>Pilot case</p> <p>with wheels with front pouch for size A 4 Inside with</p> <ul style="list-style-type: none"> 3 push-in compartments each approx. 410 x 265 mm 1 padded notebook compartment approx. 425 x 50 x 285 mm 2 business card compartments, 2 loops for pens, files can be carried in a vertical position, Two-tone combination locks, 4-stage telescopic handle approx. 1.040 mm, rubber-coated wheels with sliding bearings | <p>Art. No 5074 . 500 - 021</p> <p> 425 x 180 x 335 mm</p> <p> ~ 5.200 g</p> <p> Genuine leather</p> <p> black</p> <p> SPECIALS </p> |  |
|---|--|--|

| | | |
|---|--|---|
| <p>Pilot case</p> <p>with notebook compartment Front wall with</p> <ul style="list-style-type: none"> 1 notebook compartment, 60 mm <p>Rear wall with</p> <ul style="list-style-type: none"> 1 pouch, 30 mm <p>In the lid</p> <ul style="list-style-type: none"> 2 business card compartments 3 loops for pens <p>Artificial velvet lining Two-tone combination locks Handle hole</p> | <p>Art. No 208 . 100 - 021</p> <p> 365 x 170 x 305 mm</p> <p> ~ 3.000 g</p> <p> Genuine leather</p> <p> black</p> |  |
|---|--|---|

DOCUMENT FOLIO

| | | |
|--|---|--|
| <p>Document folio</p> <ul style="list-style-type: none"> 1 ring binder (4 rings) 1 clip for writing pad or documents 1 transparent pocket for DIN A4 2 business card compartments 2 loops for pens <p>All-round zip 1 transparent pocket for business cards outside the document folio</p> | <p>Art. No 5071 . 000 - 021</p> <p> 370 x 40 x 275 mm</p> <p> ~ 800 g</p> <p> Artificial leather</p> <p> black</p> |  |
|--|---|--|



PARAT X-treme

Definitely light

The handy sized high performance lights are suitable for every job, even under extreme working conditions.

The combination of technical features and as well as ATEX and dust explosion certifications make this light the perfect tool for every user.

The safety lights are waterproof, airtight and dustproof and provide a powerful, focused light at a distance of ~60 m (PX1) and ~40 m (PX2).

Just as unique is the possibility of using different illuminants inside the same lamp - without losing the explosion proof certification.

The PX1 and PX2 PARAT safety lights allow a unique exchange of Xenon and LED (white or amber).

A white LED penetrates the darkness almost perfectly, but not smoke and fog (visibility range less than 1 m).

For working in smoke and fog it is advisable to use an amber-colored LED.

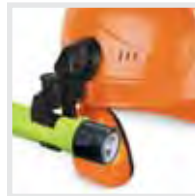

PARAT X-treme features at a glance:

- PX2 made of ABS
- PX1 made of 2 materials
XAG = high-impedance conductive plastic (1GΩ)
-----> IIC (according to DIN V14649)
Protection against ESD, EMI and RFI
ABS = non-conductive plastic -----> IIB
- PX1 is compatible with almost every helmet mount
- PX1 has also been tested for protection against dust explosion

Features of both lights

- ATEX certification zone 1
- switch at the end of the lamp
- waterproof, airtight and dustproof
- optional: fibre optic attachment











= waterproof





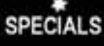

















= ATEX











PARAT 

PARAT X-treme















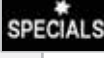







| | | |
|--|---|---|
| <p>PX 2 ATEX Zone 1 approved Material: ABS flame-yellow Reverse polarity protection (LED) LED blinks before batteries are exhausted Press button switch at the end of the light's housing Xenon = ~ 10 lumens LED = ~ 13 lumens 2 x AAA/Micro/LR03 Alkaline batteries, 1,5 V each Blister packaging, incl. batteries</p> <p>Black PX 2 lights available upon request.</p> | <p> 6.901.042.158 (Xenon) 6.901.052.158 (LED white)</p> <p> ~ 140 x 15 mm</p> <p> ~ 2,5 hours</p> <p> ~ 40 m (Xenon) / ~ 30 m (LED)</p> <p> ~ 38 g (Xenon) / ~ 40 g (LED)</p> <p>  </p> |   |
|--|---|---|

| | | |
|--|--|---|
| <p>PX 1 non-conductive ATEX Zone 1 approved / Dust approved Material: ABS flame-yellow Xenon = ~ 80 lumens LED (amber/white) = ~ 50 lumens Xenon bulb can be replaced individually Press button switch at the end of the light's housing Bi-polarity 4 x AA/LR06/Mignon Alkaline batteries, 1,5 V each Blister packaging, incl. batteries</p> | <p> 6.911.042.158 (Xenon) 6.911.052.158 (LED white) 6.911.062.158 (LED amber)</p> <p> ~ 180 x 40 mm</p> <p> ~ 3 hours</p> <p> ~ 60 m (Xenon) / ~ 50 m (LED)</p> <p> ~ 72 g (Xenon) / ~ 75 g (LED)</p> <p>  </p> |   |
|--|--|---|

| | | |
|---|---|---|
| <p>PX 1 conductive ATEX Zone 1 approved / Dust approved Material: XAG red Xenon = ~ 80 lumens LED (amber/white) = ~ 50 lumens Xenon bulb can be replaced individually Press button switch at the end of the light's housing Bi-polarity 4 x AA/LR06/Mignon Alkaline batteries, 1,5 V each Blister packaging, incl. batteries</p> | <p> 6.911.042.166 (Xenon) 6.911.052.166 (LED white) 6.911.062.166 (LED amber)</p> <p> ~ 180 x 40 mm</p> <p> ~ 3 hours</p> <p> ~ 60 m (Xenon) / ~ 50 m (LED)</p> <p> ~ 72 g (Xenon) / ~ 75 g (LED)</p> <p>  </p> |   |
|---|---|---|

| | | |
|--|---|---|
| <p>PX 1 conductive ATEX Zone 1 approved / Dust approved Material: XAG light-grey Xenon = ~ 80 lumens LED (amber/white) = ~ 50 lumens Xenon bulb can be replaced individually Press button switch at the end of the light's housing Bi-polarity 4 x AA/LR06/Mignon Alkaline batteries, 1,5 V each Blister packaging, incl. batteries</p> | <p> 6.911.042.169 (Xenon) 6.911.052.169 (LED white) 6.911.062.169 (LED amber)</p> <p> ~ 180 x 40 mm</p> <p> ~ 3 hours</p> <p> ~ 60 m (Xenon) / ~ 50 m (LED)</p> <p> ~ 72 g (Xenon) / ~ 75 g (LED)</p> <p>  </p> |   |
|--|---|---|

PARAT X-treme

| | | | |
|---|---|--|--|
|   | <p>6.901.049.999 (Xenon lamp reflector assembly) 6.901.059.999 (white LED module)</p> <p>~ 40 m (Xenon) / ~ 30 m (white LED)</p> <p>Ex ~ 15 g</p> |     | <p>Lamps, PX2</p> <p>in blister packaging</p> |
|   | <p>6.911.048.999 (Xenon bulb only) 6.911.049.999 (Xenon lamp reflector assembly) 6.911.059.999 (white LED module) 6.911.069.999 (white LED module)</p> <p>~ 60 m (Xenon) / ~ 50 m (white LED)</p> <p>Ex ~ 20 g</p> |     | <p>Lamps, PX1</p> <p>in blister packaging</p> |
|  | <p>6.901.002.151 (for PX2) 6.911.002.151 (for PX1)</p> <p>~ 254 mm</p> |   | <p>Fibre optic attachment, PX1 / PX2</p> <p>in plastic bag</p> |
|  | <p>6.911.004.154</p> <p>~ 190 mm</p> |   | <p>Traffic wand, PX1</p> <p>in plastic bag</p> |
|  | <p>6.902.016.151</p> |  | <p>Helmet mount</p> <p>for DIN 14940 / DIN EN 443 and Schubert F110 helmets</p> <p>in plastic bag</p> |
|  | <p>6.902.026.151</p> |  | <p>Helmet mount universal, non-adjustable</p> <p>for DIN 14940 / DIN EN 443 and Schubert F110 helmets</p> <p>in plastic bag</p> |
|  | <p>6.902.027.151</p> |  | <p>Helmet mount universal, adjustable</p> <p>for DIN 14940 / DIN EN 443 and Schubert F110 helmets</p> <p>in plastic bag</p> |

PARAT X-treme

PX1 – everything at a glance!

The PARAT X-treme safety lights are specifically developed for fire fighters, police, armed forces and industry. The first of this product range is the safety light Model PX1 which is powered by 4x AA/Mignon batteries. The PX1 is approved for the use in potentially explosive atmospheres (triggered by gas /zone 1 or dust). With the DIN V 14649, new future standards for firemen's spot lamps are being set.

The PX1 already meets these standards today, but as a helmet light. The most important aspect of a good work light is the quality of the light emitted, and not just the intensity at the axis of the beam. Here the PARAT light engineering skills come into operation. PARAT safety lights produce a focussed and powerful emission of light that assures a clean, shadow free, beam. The Parat X-treme PX1 outputs ~80 lumen (Xenon), and ~60 lumen (LED). Most comparable work-lights average a maximum of ~40 lumen and therefore do not reach the level of brightness of the PX1. The new X-treme safety lights are an outstanding product due to successful ergonomics, appealing design, the use of high-quality materials in their manufacture, and the level of certification achieved. The rubber shrouded push-button switch is not affected or damaged by contact with oil. Furthermore the lamp is so constructed that it is compatible with all current helmet mounts. The PX1 is available in three colours (flame-yellow, red and light-grey).





Light Sticks

Here the chemistry is right

AmeriGlo Light Sticks are non-toxic, non-corrosive, provide a heatless light and are easy to use. They work without batteries, without bulb and without electricity. Furthermore rain, wind and water have no influence on illuminating power and burning time. Each Light Stick contains 2 components in a sealed plastic housing: an activator and a luminescent material. To activate the Light Stick, it has to be bent and hooked on

shortly - thereby the inner glass capsule bursts. Finally the Light Stick has to be shaken, so that both chemicals can intermix and produce light. The modification of both chemicals, determines colour, brightness and burning time. Each Stick is individually packed in foil, to guarantee a long, optimal storing.

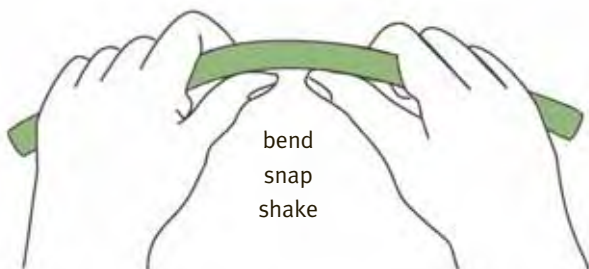

The features of the Light Stick series at a glance:

- no formation of shades and antiglare
- directly ready for use
- visible up to 1,6 km
- fulfill military and industry standards
- can be attached to operating clothes
- maintenance-free



= waterproof



= domestic waste

PARAT

LIGHT STICKS

Light Stick 4" - Display 6 hours burning time

green NSN No. applied
orange NSN No. applied

Amount per delivery: 640 pieces
Packaging: 16 Displays à 40 pieces



6.406.040.993 (green)
6.406.040.994 (orange)
~ 10,16 cm
~ 6 h



Light Stick 6" - Display 12 hours burning time

green NSN No. 6260-01-074-4229
yellow NSN No. 6260-01-196-0136

Amount per delivery: 180 pieces
Packaging: 6 Displays à 30 pieces
(each 15 green + 15 yellow)



6.600.030.999 (green/yellow)
~ 15,24 cm
~ 12 h



Light Sticks 6" 30 minutes burning time

green NSN No. 6260-01-508-6010
orange NSN No. applied
blue NSN No. 6260-01-508-6015
red NSN No. 6260-01-230-8601
yellow NSN No. 6260-01-074-4230
white NSN No. 6260-01-247-0368

Amount per delivery: 600 pieces
Packaging: 60 cardboards à 10 pieces



6.630.010.993 (green)
6.630.010.994 (orange)
6.630.010.995 (blue)
6.630.010.996 (red)
6.630.010.998 (yellow)
6.630.010.999 (white)
~ 15,24 cm
~ 30 min



Light Stick 6" 8 hours burning time

blue NSN No. 6260-01-178-5560
white NSN No. 6260-01-218-5146

Amount per delivery: 600 pieces
Packaging: 60 cardboards à 10 pieces



6.608.010.995 (blue)
6.608.010.999 (white)
~ 15,24 cm
~ 8 h



LIGHT STICKS



6.612.010.993 (green)
 6.612.010.994 (orange)
 6.612.010.996 (red)
 6.612.010.998 (yellow)

~ 15,24 cm
 ~ 12 h



Light Stick 6" - Display 12 hours burning time

green NSN No. 6260-01-074-4229
 orange NSN No. applied
 red NSN No. 6260-01-178-5559
 yellow NSN No. 6260-01-196-0136

Amount per delivery: 600 pieces
 Packaging: 60 cardboards à 10 pieces



6.100.210.993 (green)
 6.100.210.998 (yellow)

~ 25,40 cm
 ~ 2 h



Light Stick 10" - Display 2 hours burning time

green NSN No. applied
 yellow NSN No. applied

Amount per delivery: 160 pieces
 Packaging: 16 cardboards à 10 pieces

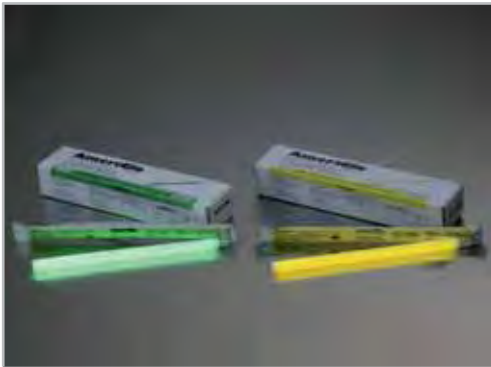

6.121.210.993 (green)
 6.121.210.998 (yellow)

~ 30,48 cm
 ~ 12 h



Light Stick 12" - Display 12 hours burning time

green NSN No. applied
 yellow NSN No. applied

Amount per delivery: 160 pieces
 Packaging: 16 cardboards à 10 pieces



6.151.205.993 (green)
 6.151.205.998 (yellow)

~ 38,10 cm
 ~ 12 h



Light Stick 15" - Display 12 hours burning time

green NSN No. applied
 yellow NSN No. applied

Amount per delivery: 80 pieces
 Packaging: 16 cardboards à 5 pieces

LIGHT STICKS

Light Stick Ultra-Orange 10" - Display 5 minutes burning time

ultra-orange NSN No. applied
Amount per delivery: 160 pieces
Packaging: 16 cardboards à 10 pieces

Light Stick Ultra-Orange 6" - Display 5 minutes burning time

ultra-orange NSN No. 6260-01-247-0363
Amount per delivery: 600 pieces
Packaging: 60 cardboards à 10 pieces

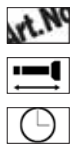

6.100.510.994 (ultra-orange)
6.605.010.994 (ultra-orange)
~ 24,40 cm / 15,24 cm
~ 5 min



All 10" Light Sticks will be delivered including metal rack

Always and everywhere ready for operation!

The new Light Sticks

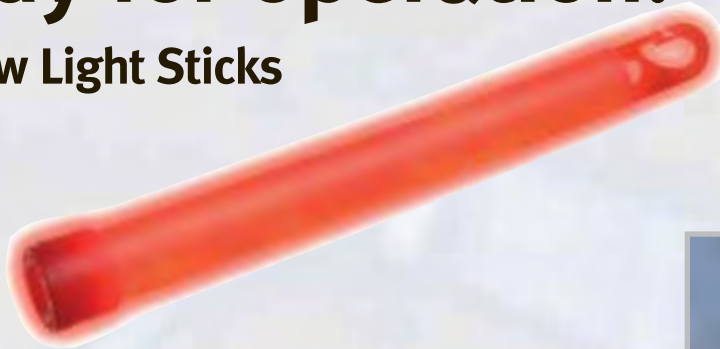

AmeriGlo Light Sticks are designed for professional, once-only use.

Light Sticks provide optimum illumination and lighting duration at temperatures between +15°C and +27°C. At higher temperatures, Light Sticks provide a brighter light. If the temperature is lower, the light will last longer but will be less bright. For optimum protection against dust and moisture even during long storage periods, all AmeriGlo Light Sticks are individually packed in foil.

Why different colours?

Yellow is highly visible through black smoke.
Green is outstandingly visible through white smoke.
Blue is ideal for traffic checkpoints.
Red / Orange is well-suited for marking hazards.
White for an exact colour matched illumination.

Sizes:

4-inch – 10,16 cm
6-inch – 15,24 cm
10-inch – 25,40 cm
12-inch – 30,48 cm
15-inch – 38,10 cm

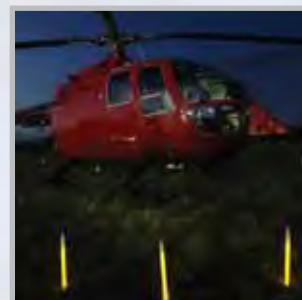
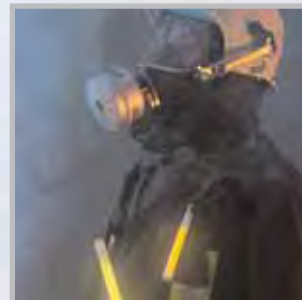

PARAT in Europe

Trade representatives in Germany:

 ① **Karl-Heinz Janneck GmbH**
Industrie-Vertretungen
Anemonenweg 4
D-55129 Mainz
Phone: +49 (0) 6136 – 42828
Fax: +49 (0) 6136 – 42556
Mail: k.h.janneckgmbh@gmx.de

 ② **HKL GmbH**
Industrie-Vertretungen
Hauptstr. 88
D-42349 Wuppertal
Phone: +49 (0) 202 – 470002
Fax: +49 (0) 202 – 4781633
Mail: info@hkl-gmbh.com
Net: www.hkl-gmbh.com

PARAT

Headoffice
PARAT-WERK
Schönenbach GmbH + Co. KG
An der Hasenjagd 7
D-42897 Remscheid
Phone: +49 (0) 21 91 / 911-0
Fax: +49 (0) 21 91 / 911-125
Mail: info@parat.de
Net: www.parat.de

 ③ **Edmund Rosenheimer**
Industriervertretung
Eggentalerstr. 12
D-85778 Haimhausen
Phone: +49 (0) 8133 – 2767
Fax: +49 (0) 8133 – 6838
Mail: edi.rosenheimer@t-online.de

 ④ **Hartmut Lauble**
Fahrgasse 17
D-63477 Maintal
Phone: +49 (0) 6181 – 492011
Fax: +49 (0) 6181 – 45325
Mail: hartmut.lauble@t-online.de

 ⑤ **Hans Dieter Schmid GmbH**
Handelsvertretung
Werkzeuge/Maschinen
Friedhofsfußweg 6
D-73527 Schwäbisch-Gmünd
Phone: +49 (0) 7171 – 71633
Fax: +49 (0) 7171 – 77359
Mail: schmid.handel@t-online.de

 ⑥ **Ronald Tessmer**
Handelsvertreter
Grüner Grund 30
D-33428 Harsewinkel
Phone: +49 (0) 5247 – 3466
Fax: +49 (0) 5247 – 1655
Mail: r.tessmer@t-online.de

 ⑦ **Siegfried Teuber**
Werksvertretungen
Gewerbering 10
D-90547 Stein
Phone: +49 (0) 911 – 6899770
Fax: +49 (0) 911 – 6899771
Mail: siegfriedteuber@t-online.de

 ⑧ **Wenzel GmbH**
Altendorfer Tor 23
D-37574 Einbeck
Phone: +49 (0) 5561 – 934260
Fax: +49 (0) 5561 – 934230
Mail: info@wenzeleinbeck.de

 ⑨ **Frank Wolf**
Industriervertretungen CDH
Juri-Gagarin-Ring 11
D-19370 Parchim
Phone: +49 (0) 3871 – 468930
Fax: +49 (0) 3871 – 4689355
Mail: info@wolf-iv.de
Net: www.wolf-iv.de

Trade representatives in Europe:

 **Austria**
I. Müller GmbH
Generalvertretungen
Peter Paul-Straße 15
A-2201 Gerasdorf bei Wien
Phone: +43 (0) 2246 – 2146
Fax: +43 (0) 2246 – 20260
Mail: info@imueller.at
Net: www.imueller.at

 **Belgium**
(German + Flemish part)
BM Tools
Martin Van Steen
Itterbeekseiaan 16
B-1700 Dilbeek
Phone: +32 (0) 256-98171
Fax: +32 (0) 256-70179
Mail: info@bmttools.be

 **Belgium**
(French part)
BM Tools
Bernhard Messiaen
Harlemboislaan 11
B-8530 Harelbeke
Phone: +32 (0) 56-216636
Fax: +32 (0) 56-227375
Mail: info@bmttools.be



**Czech Republic**

ABQ Agency s.r.o.
Kundratka 17
CZ-18082 Praha 8
Phone: +420 283841981-3
Fax: +420 283841981-3
Mail: ab.efekt@comp.cz
Net: www.abqagency.cz

**Hungaria**

Zorex KFT
Köbányai út 49/B
HU-1101 Budapest
Phone: +361 261-7877
Fax: +361 261-9413
Mail: zorex@zorex.hu
Net: www.zorex.hu

**Poland**

Biurow Handlowe
Arkadiusz Baraniok
ul. Poprzeczna 1
PL-61-315 Poznań
Phone: +48 (0) 61-8798298
Fax: +48 (0) 61-8719001
Mail: info@baraniok.com.pl
Net: www.baraniok.com.pl

**Denmark**

HJS Værktøj A/S
Marielundvej 17
DK-2730 Herlev
Phone: +45 44 84 40 44
Fax: +45 44 84 08 84
Mail: hjs@hjs.dk
Net: www.hjs.dk

**Israel**

George Kawaz
27 derech petah-tikva
IL-66184 Tel-Aviv
Phone: +972 (0) 3-5 66 13 99
Fax: +972 (0) 3-5 60 73 85
Mail: kawaz@inter.net.il
Net: www.kawaz.co.il

**Portugal / Spain**

Juan Antonio Pires
c./Mogoda, 1-5, Edificio Nodus
Pno. Ind. Can Salvatella
E-08210 Barberà del Vallès/Barcelona
Phone: +34 93 729 72 40
Fax: +34 93 729 72 41
Mail: juan.pires@parat.de

**Finland**

Leatherman Finland / Rovac OY
PL 2227
FIN-96201 Rovaniemi
Phone: +358 (0) 207-310431
Fax: +358 (0) 207-310439
Mail: Sales@leatherman.fi
Net: www.leatherman.fi

**Italy**

E.T.R. Eurotrade
Via Sordelli, 3
I-21040 Venegono Inf. (VA)
Phone: +390 331 86 49 60
Fax: +390 331 86 51 10
Mail: info@etreurotrade.it
Net: www.etreurotrade.it

**Sweden**

Vageler + Christiansen
Export-Import
Niels-Bohr-Ring 12 A
D-23568 Lübeck
Phone: +49 (0) 451 - 32055
Fax: +49 (0) 451 - 32057
Mail: vachri@t-online.de
Net: www.vachri.de

**France**

A.F.C. S.a.r.l.
70, Rue des Monts Clairs
B.P. 60
F-92700 Colombes, Paris
Phone: +33 (0) 156838400
Fax: +33 (0) 156838409
Mail: AFC3@wanadoo.fr

**Luxembourg**

Karl-Heinz Janneck GmbH
Industrie-Vertretungen
Anemonenweg 4
D-55129 Mainz
Phone: +49 (0) 6136 - 428 28
Fax: +49 (0) 6136 - 425 56
Mail: k.h.janneckgmbh@gmx.de

**Switzerland/Liechtenstein**

Robert Rieffel AG
Generalvertretungen
Widenholzstrasse 8
CH-8304 Wallisellen
Phone: +41 (0) 44-8773333
Fax: +41 (0) 44-8773322
Mail: security@rieffel.ch
Net: www.rieffel.ch

**Great Britain**

PATHFINDER-FOX Limited
Unit C1 Europa Trad. Estate
Stoneclough Road, Radcliffe
M 26 1 GG, Manchester
Phone: +44 (0) 1204868630
Fax: +44 (0) 1204868631
Mail: sales@pathfinder-fox.co.uk
Net: www.pathfinder-fox.co.uk

**Netherlands**

Biegel & Bollentin B.V.
Celsiusweg 12 A
NL-6662 PX ELST
Phone: +31 (0) 481-351295
Fax: +31 (0) 481-452980
Mail: sales@biegel.nl

**Greece**

NTOUNTOLAKIS & SIA EE
Agxialoy 222-224
GR-18546, Piraeus
Phone: +30 (0) 2104632555 /
+30 (0) 2104119076
Fax: +30 (0) 2104223412
Mail: sales@ntountoulakis.gr
Net: www.ntountoulakis.gr

**Norway**

OULIE-HANSEN A/S
Ravnåsveien 3
N-1254 Oslo
Phone: +47 (0) 22 62 05 00
Fax: +47 (0) 22 61 10 17
Mail: firmapost@oulie-hansen.no
Net: www.oulie-hansen.no

Terms and Conditions of Sale, Delivery and Payment of PARAT (Issue 10/07)

§ 1 Scope

1. All contracts for the sale of goods by PARAT (hereinafter referred to as „Contracts“) shall be governed solely by these General Terms and Conditions. Any general terms and conditions of customers in deviation from these General Terms and Conditions shall not apply to Contracts unless PARAT has specifically agreed to the application of such terms and conditions in writing. These General Terms and Conditions shall also apply in any case in which PARAT, having knowledge of general terms and conditions of customers in deviation from these General Terms and Conditions, delivers goods to customers without expressing any reservations.
2. By awarding a Contract to PARAT, the customer shall be deemed to have accepted these General Terms and Conditions.

§ 2 Conclusion of the contract/Requirement for Written Form

1. Unless otherwise agreed in writing, quotations made by PARAT shall not be binding on PARAT. A Contract shall not be deemed to have been concluded until and unless it has been confirmed in writing by PARAT. All Contracts shall be governed by the text of the written confirmation of contract issued by PARAT.
2. Agreements, statements and other information shall not be binding on PARAT unless made in writing. Declarations made in telephone conversations, telegrams, fax messages, emails or text messages shall not be valid unless confirmed without delay in writing.
3. The latest valid catalogues of PARAT shall be deemed to be an integral part of quotations issued by PARAT. As towards customers who are not consumers, any descriptions of the properties of products given in catalogues or in discussions shall not constitute warranties as to such properties or the durability of products. Drawings, illustrations, dimensions, weights and other performance data shall not be binding unless expressly agreed in writing. PARAT reserves the right to make changes in models and in its production range within customary quantity and quality tolerance ranges, provided however that PARAT shall not be obligated to make such changes on products already supplied by PARAT. PARAT shall be entitled to modify products without giving specific notice to customers. In case of products produced with special order for customers, PARAT reserves the right to supply, and charge for, a quantity of up to 5 % more or less than that ordered by the customer.

§ 3 Delivery Times

1. It is expressly stated that all delivery times shall be subject to the delivery to PARAT in good time of the correct products or raw materials concerned.
2. Even where firm delivery dates have been agreed, PARAT shall not be responsible for any delay in delivery due to force majeure or any circumstance making it impossible or unreasonably difficult for PARAT to deliver the goods. Such circumstances shall include, without limitation, strikes, lock-outs and requirements imposed by authorities, including such circumstances affecting sub-contractors of PARAT or their sub-contractors. In the event of delivery being prevented by any such circumstance, PARAT shall be entitled to postpone the delivery of the goods or the performance of the services by the duration of such circumstances and a reasonable time for preparation or to rescind in whole or in part the unperformed part of the Contract affected by such circumstances. In the event of delivery under any Contract being prevented by such circumstances of force majeure for more than three months, the customer shall grant PARAT a reasonable period of grace to perform the Contract. During said grace period, the customer shall not be entitled to claim damages of PARAT or refuse delivery under the Contract. In the event that said grace period expires without the Contract having been performed by PARAT, the customer shall be entitled to rescind the Contract.
3. Delivery periods shall start on the date of issue of the confirmation of Contract by PARAT and, in the event of delays in delivery or performance, on the date when PARAT notifies the customer.
4. If the dispatch of any goods is delayed at the request of the customer or for reasons for which PARAT is not responsible, the customer shall bear any additional cost incurred by PARAT by reason of such delay. In the event of any such delay as a result of wilful act or omission or gross negligence of the customer, the risk of loss or deterioration of the goods concerned shall be transferred to the customer upon notification of the customer by PARAT that the goods concerned are ready for dispatch.
5. PARAT shall be entitled to make partial deliveries under any Contract and to deliver the goods covered by any Contract earlier than the agreed date always provided that the customer can reasonably be expected to accept such partial or earlier delivery. In any such case, the customer shall not be entitled to claim damages of PARAT in lieu of the full performance of the Contract unless the customer has no interest in the full performance of the Contract for reasons which are objectively justified.
6. Should PARAT, for reasons for which PARAT is responsible, fail to comply with delivery dates or deadlines which PARAT has agreed as binding or be in arrears with deliveries for which such dates or deadlines have been agreed, the customer shall be entitled to claim liquidated damages from PARAT in the amount of 3% of the net value of the delayed goods or services for each complete week of delay up to a maximum amount of 15% of said value. PARAT shall be entitled to prove that the loss or damage suffered by the Customer is less than said amount, in which case PARAT shall only be obligated to pay compensation to the customer for such lower loss or damage.
7. It shall not be necessary for the customer to grant PARAT any such grace period in the case of Contracts for the delivery of goods with fixed delivery dates or in any case in which the immediate rescission of the Contract by the customer is justified by other circumstances having due regard to the interests of the two parties.
8. Within said grace period, the customer shall not be entitled to claim damages of PARAT or to claim damages under the Contract. If said grace period expires without PARAT having performed the contract, the customer shall be entitled to rescind the Contract. The customer shall not be entitled to rescind the Contract in any case in which the customer is wholly or substantially responsible for the circumstances which would otherwise entitle the customer to rescind the Contract or in any case in which PARAT could reasonably expect the customer not to rescind the Contract despite the setting of a grace period by the customer.
9. PARAT shall only be obligated to comply with agreed delivery dates if the customer performs all of its obligations under the Contract properly and in good time.
10. During any delay by the customer in taking delivery of any goods under the Contract, the liability of PARAT shall be limited to wilful act or omission or gross negligence and, as to amount, to the net value of the goods concerned.

§ 4 Transfer of Risk/Packaging

1. The risk of the loss or deterioration of the goods under any Contract shall be transferred to the customer when said goods are dispatched from the plant of PARAT in the case of goods forwarded by the customer and when the goods are delivered to the customer in the case of goods delivered by PARAT.
2. All goods shall be dispatched at the cost, risk and expense of the customer.
3. Packing materials shall be charged to the customer at cost.
4. Upon the receipt of goods, the customer shall notify PARAT forthwith of any damage for which PARAT is responsible which may have occurred in shipment. Any defective parts shall be returned by the customer carriage-paid to the PARAT plant in Neureichenau. If any such notification is received by PARAT more than two weeks after the receipt of the goods by the customer, any claims for damages by the customer shall be excluded unless the customer is not responsible for the delay in such notification.

§ 5 Prices and Terms of Payment

1. All prices stated in any quotation issued by PARAT in any quotation or Contract shall be in euros and shall not include value-added tax, carriage, insurance or other expenses.
2. In the case of Contracts in which a delivery time in excess of four months is laid down, PARAT reserves the right to increase the prices agreed in accordance with cost increases connected with collective bargaining agreements or increases in material costs. In the event that any such increase exceeds 5% of the price agreed under any Contract, the customer shall be entitled to rescind said Contract.
3. The customer shall not be entitled to exercise any right of set-off except where such claim has been accepted by PARAT or an enforceable judgment has been rendered in respect of such claim, in which cases the customer shall also be entitled to exercise a right of retention in respect of the amount concerned. The customer shall also be entitled to exercise a right of retention in the event of defects for which PARAT is responsible in the goods supplied under any Contract, always provided that the amount retained by the customer in any such case shall be reasonable in view of the actual defects in the goods supplied.
4. The provisions of Sections 273 and 320 of the German Civil Code shall be deemed to have been waived in the case of Contracts between PARAT and businesses and tradesmen, as defined in the German Commercial Code, always provided that said waiver shall not apply in the case of wilful or grossly negligent breach of the Contract concerned or in any case in which PARAT has already received that part of the remuneration agreed under the Contract concerned which is commensurate with the goods supplied by PARAT under said Contract which were free from defects.
5. Should the customer suspend payments or fail to redeem any cheque or should PARAT become aware of any other circumstances which call the credit-worthiness of the customer into question, PARAT shall be entitled to require the customer to pay any amounts then outstanding to PARAT forthwith even if PARAT had previously accepted cheques issued by the customer. In any such case, PARAT shall also be entitled to refuse to deliver goods under the Contract or to require the customer to make advance payments or provide other appropriate security. Should the customer fail to comply within a reasonable time with any such request by PARAT to provide security, PARAT shall be entitled to rescind the contract and/or claim damages from the Customer.
6. Representatives of PARAT are not entitled to collect amounts due unless they submit written authorizations to the customer. PARAT only accepts cheques and bills of exchange on account and any bank charges, discount fees and collection charges shall be borne by the customer. The customer shall not be deemed to have performed its payment obligation until the amount due has been credited to the account of PARAT.
7. Should the customer be in arrears with any payment owed to PARAT, PARAT shall be entitled to require the customer to pay interest at the rate charged by banks for current account loans, or at a rate of 8 percentage points above the then discount rate, whichever may be higher. In any such case, PARAT shall also be entitled to claim damages from the customer in respect of delayed payment.

8. Invoices issued by PARAT shall be due and payable within 8 days of the date of receipt thereof by the customer with a cash discount of 3 %, within 14 days of the date of receipt with a cash discount of 2 % or within 30 days of the date of receipt without deduction.

§ 6 Warranty

1. The customer shall inspect the goods supplied under any Contract immediately upon the delivery thereof and shall notify PARAT of any evident defects in such goods in writing within 14 days of the delivery thereof. For the purpose of these provisions, defects shall be defined in accordance with the applicable statutory provisions.
2. In the event that any complaint concerning defects in goods received from the customer in good time and proper form is justified, PARAT shall be entitled, at the option of PARAT, to remedy such defects free of charge to the customer or to supply goods free from defects to the customer free of charge, in which case the customer shall return the defective goods concerned to PARAT. Any other remedies of the customer shall be excluded. This provision shall not apply in the event that PARAT has wilfully concealed the defect concerned from the customer or has assumed guarantees as to the properties of the products concerned. In the event that PARAT does not succeed in remedying any defects in goods supplied to the customer after a maximum of two attempts or such attempts are not made within a reasonable period of time granted to PARAT by the customer for such purpose, the customer shall be entitled, at the option of the customer, to abate the price payable under the Contract or to rescind the Contract. These rights of the customer shall be without prejudice to the right of the customer to claim damages of PARAT.
3. The warranty period for goods supplied to the customer by PARAT shall be one year. Claims made in connection with defects in goods supplied by PARAT shall be forfeited unless made within one year of the delivery of the goods to the customer, provided however that this provision shall not apply to liability in the event of wilful or fraudulent act or omission, in which case the statutory period of forfeiture shall apply.
4. These provisions shall not apply to any contracts between PARAT and consumers.

§ 7 Recourse/duty not notify

1. The customer shall be obligated to notify PARAT promptly in writing, stating precisely the type and scope of the defects concerned, in the event that any consumer or client of the customer complains to the customer of defects in any product supplied to the customer by PARAT or any consumer or client of the customer sets the customer a grace period for remedial action in connection with any such defects. In any such case, PARAT shall be entitled to perform the Contract concerned at any time, in which case the customer shall return to PARAT any of the goods covered by the Contract which may still be in the possession of the customer. The customer shall be obligated to reserve the right to repair defects in products supplied by PARAT as towards its clients.

§ 8 Liability

1. PARAT shall be under no liability whatsoever to pay damages to the customer in connection with defects in goods supplied or other breaches of the Contract by PARAT, even in the event of claims made against the customer by consumers or clients. This shall not apply in the event of death, personal injury or damage to health resulting from any wilful or negligent infringement of obligations by PARAT or the servants, agents or employees of PARAT or to other loss or damage resulting from any wilful or grossly negligent infringement of obligations by PARAT or the servants, agents or employees of PARAT.
2. The liability of PARAT in connection with any negligent infringement of any essential or material provision of the Contract shall be limited to the loss or damage typically associated with the type of Contract concerned which could reasonably be foreseen.

§ 9 Retention of Title

1. PARAT shall retain title to the goods supplied under the Contract until the customer has performed all of its obligations towards PARAT in connection with the entire transaction. In the event of a breach of the Contract by the customer, including without limitation a delay in payment by the customer, PARAT shall be entitled to repossess the goods to which it retains title. The repossession of goods by PARAT shall not be deemed to constitute rescission of the Contract except where rescission is confirmed by PARAT in writing. The attachment of goods by PARAT shall always be deemed to constitute rescission of the Contract concerned. PARAT shall be entitled to sell goods which it has repossessed; the proceeds of any such sale, less reasonable sales expenses, shall be deducted from the amount owed by the customer to PARAT.
2. Should any third party attach or attempt to issue execution over goods affected by retention of title, the customer shall notify PARAT forthwith and shall submit to PARAT such information as PARAT may require for instituting proceedings in opposition to execution under Section 771 of the German Code of Civil Procedure. The customer shall compensate PARAT for any loss suffered by PARAT as a result of the inability of a third party to reimburse to PARAT the expenses incurred both in court and out-of-court in connection with action under Section 771 of the German Code of Civil Procedure.
3. The customer shall be entitled to sell goods affected by retention of title in the course of its normal business. The customer hereby assigns to PARAT in full by way of security any amounts which may become due to the customer from its customers or third parties in respect of the sale of goods affected by retention of title, irrespective of whether such goods have been processed prior to resale. The customer shall continue to be entitled to collect such amounts assigned to PARAT. This entitlement shall be without prejudice to the right of PARAT to collect such amounts itself, always provided that PARAT shall not exercise such right unless the customer fails to meet payment obligations under the Contract or is in arrears with any such payments or insolvency proceedings are instituted against the customer or the customer suspends payments. In any such case, PARAT shall be entitled to require the customer to state the amounts assigned to PARAT and the debtors owing such amounts, to provide PARAT with all the information required for the collection of such amounts, to submit the necessary documents to PARAT and to notify the debtors concerned that the amounts outstanding have been assigned to PARAT. PARAT shall also be entitled to disclose details of such assignment and the customer shall no longer be entitled to collect amounts on behalf of PARAT.
4. Where the customer processes or modifies goods to which PARAT retains title, such processing or modification operations shall be deemed to have been performed on behalf of PARAT, but without any responsibility of PARAT. If the customer uses such goods in the production of other goods, the customer shall transfer to PARAT a share in the title to such other goods which shall be pro rata to the share of the value of the goods supplied by PARAT in the finished goods at the time of processing. Such goods shall be governed by the same provisions as goods supplied by PARAT to which PARAT retains title.
5. Where the customer mixes goods to which PARAT retains title with other goods in such a way that they cannot be separated, the customer shall transfer to PARAT a share in the title to the goods produced by said mixing which shall be pro rata to the share of the value of the goods supplied by PARAT in the finished goods at the time of mixing. In the event that such mixing takes place in such manner that the resulting goods of the customer are the main product, it is hereby agreed that the customer shall transfer to PARAT a pro rata share in the title to the goods produced. The customer shall store for PARAT goods to which PARAT retains title or a share in the title.
6. By way of security for amounts owed to PARAT by the customer, the customer shall also be deemed to have assigned to PARAT any claims by the customer against third parties arising in connection with the joining of any goods supplied by PARAT to any land or building.
7. PARAT hereby undertakes to release securities to the customer upon request by the customer if and when the value of such securities exceed the amount owed to PARAT by the customer by more than 20%. In any such case, PARAT shall select the securities to be released at its sole discretion.

§ 10 Place for Performance/Venue for Disputes/Applicable Law

1. The place of performance for all rights and obligations under the Contract shall be Remscheid.
2. In the event that the customer is a person or organization subject to obligatory registration in the commercial register, Remscheid shall be the venue for any disputes arising out of or in connection with the Contract. The same shall apply to any proceedings in connection with cheques or bills of exchange, including, without limitation, any proceedings for orders to pay debts. PARAT shall also be entitled to institute proceedings against the customer in the court having jurisdiction over its place of residence or registered office.
3. The Contract shall be governed by and construed and interpreted in accordance with the law of the Federal Republic of Germany and any disputes arising between the parties out of or in connection with the Contract shall be settled under German law. Customers located outside Germany shall sign and return copies of these General Terms and Conditions in English and German to PARAT within 14 days and shall submit to PARAT written confirmation that these General Terms and Conditions shall apply to the Contract.

§ 11 Matters Not Provided for/Invalid etc./Provisions

1. Any matter not provided for in the Contract shall be governed by the applicable statutory provisions. Any standard terms and conditions of the business partner in deviation from the Terms and Conditions of Sale, Delivery and Payment of PARAT shall not apply.
2. If any of the provisions of these General Terms and Conditions is or becomes ineffective, the other provisions of these General Terms and Conditions shall remain in full force and effect. In the event that any matter is not provided for as a result of the ineffectiveness of any provision of these General Terms and Conditions, a provision in accordance with the purpose and intent of these General Terms and Conditions shall be applied.

§ 12 Copyright

1. PARAT shall retain all rights to any illustrations, drawings, calculations and other documents made available by PARAT. Such documents shall not be made available to third parties without the prior specific written permission of PARAT. These provisions shall apply, without limitation, to such documents as have been marked „confidential“ by PARAT. Such documents shall not be printed or copied in whole or in part or used for any purpose other than that laid down in the Contract without the prior specific written permission of PARAT.



The PARAT team in Remscheid is looking forward to working with you.

www.parat.de



PARAT-WERK

Schönenbach GmbH + Co. KG
P.O. BOX 110660
D-42897 Remscheid
Phone: +49 (0) 2191 911-0
Fax: +49 (0) 2191 911-125
Mail: info@parat.de
Net: www.parat.de

